

Installation Manual
Snow Melt Unit 0550
Version 2.14.1

The logo consists of the letters 'HBX' in a bold, black, sans-serif font. The letters are centered between two horizontal red bars. The background of the entire page features a pattern of thin, light-colored lines that create a sense of depth and movement, with a darker, more solid area on the left side.

HBX

SNO-0550

HBX Control Systems Inc.



TABLE OF CONTENTS

Introduction 1-3
 Safety Symbols & Warnings 1
 Receipt & Inspection..... 1
 Description..... 2
 Technical Data and Dimensions..... 3

Wiring & Installation 4
 Wiring 4
 Installation 4

Programming SNO-0550 5-13
 Status Screen..... 5
 Status & Mode Descriptions..... 6
 Control Setup..... 6
 Navigating the SNO-0550..... 7
 Setup Menu..... 7
 Snow Rate Settings..... 8
 Design Temperature Settings..... 9
 Slab Settings..... 10
 System Settings..... 11
 Testing Settings..... 12
 WiFi Settings..... 13

WiFi Network Setup..... 14-17
 Connecting to a Wireless Network iOS..... 14-15
 Connecting to a Wireless Network Android..... 16-17
 Adding the SNO-0550 to the HBX App..... 18
 HBX App Functionality..... 19

Sample Wiring and Diagrams..... 20-21
Troubleshooting Guide..... 22-23
Testing and Troubleshooting Procedure..... 24
Sensor Errors..... 24
Warranty Information..... 25

Table of Contents

HBX SNO-0550 SNOW MELT CONTROLLER

INTRODUCTION

This manual will help with the installation, parameter setting, troubleshooting and general maintenance requirements for the controller. To guarantee the safe and reliable operation of this control, you must first read this manual in detail and take particular note to any and all warnings or caution directives prior to connecting to AC power.

Please consult and install the heating appliance in accordance with manufacture's recommendations.

QR CODE

Each SNO-0550 is labeled with a QR code, which when scanned will link to a digital version of this manual. If this manual is ever lost or damaged, simply scan this with a compatible device to download the latest manual version.

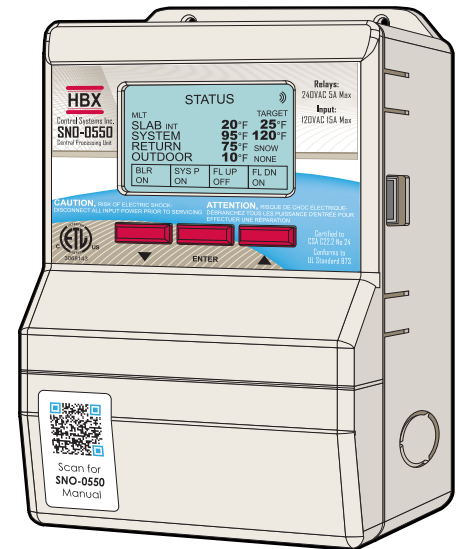

WARNING: This product can expose you to chemicals including lead, which is known to the State of California to cause cancer and birth defects or other reproductive harm. For more information go to www.P65Warnings.ca.gov.

SAFETY SYMBOLS & WARNINGS



Extreme Hazard

This action poses a serious threat that could result in personal injury or death, as well as permanent damage to the equipment. Proceed with caution.



Moderate Hazard

This action may cause personal injury or have adverse effects on the installation process if handled incorrectly.



Disconnect Power Source

The presence of low voltage(24VAC) or high voltage(120VAC) could result in personal injury or permanent damage to components or equipment.



Point of Interest

This point clarifies pertinent information, or brings your attention to an action that may have adverse effects on the installation process.



Drawing Reference

Refer to the specified electrical or mechanical drawing at the back of the manual.



Only suitably qualified individuals with formal training in electrical and Hydronic controls should attempt the installation of this equipment. Incorrect wiring and installation will affect the warranty provided with this unit. Wiring must be completed in accordance with the codes and practices applicable to the jurisdiction for the actual installation.



Use only copper conductor supply wire suitable for at least 105 °C



The HBX SNO-0550 is a microprocessor based controller and as such is not to be regarded as a safety (limit) control. Please consult and install the heating or cooling appliance in accordance with the manufacturer's recommendations.

RECEIPT & INSPECTION

After receiving, inspect the unit for any possible physical damage that may have occurred during transportation.

After unpacking the unit make sure the box contains:

- 1 x Remote Outdoor sensor (Part #OUT-0100)
- 2 x Universal sensors (Part #029-0022)
- 1 x Terminal Screwdriver (2.5mm)
- 2 x Cable ties
- 1 x Manual

HBX SNO-0550 SNOW MELT CONTROLLER

DESCRIPTION

The SNO-0550 is a stand-alone snowmelt control that utilizes a unique sensor technology unmatched by any other snowmelt control system on the market today. This control utilizes proprietary sensor technology to detect falling snow. The snowmelt sensor uses a heater to melt the snow that lands on the sensor. The control then measures actual snow fall rate.

The SNO-0550 consists of numerous exceptional features including settings for your snow fall intensity as well as an adjustable ΔT . This distinctive design incorporates our user friendly programming features, while offering applications and snow melt provisions over and above conventional slab sensing. With the ability to control a system and an injection pump, or a floating action valve for mixing purposes, this value added stand-alone control is suitable for single scale projects, or multi-zone projects that require individual optical sensors for each melt zone.

The SNO-0550 can also be controlled remotely using your smartphone or tablet device with the free HBX ThermoLinx App. The ThermoLinx App allows you to control your snow melt system with the ability to set snow fall rates, adjust/monitor targets, set slab demands, and the ability to turn on/off your snow melt system anytime, anywhere.

Some features of the HBX SNO-0550 are:

- Pre-set snow conditions
 - Very Light
 - Light
 - Moderate
 - Heavy
- Utilizes optical snow fall settings technology
- Integrated slab sensor (can be installed remotely)
- Injection and mixing valve control
- System pump control
- Warm / Cold weather shutdown
- Smart testing function
- Wi-Fi Enabled
- Remotely access via Apple® and Android™ smartphone or tablet devices

As seen here, based on a “Light” snowfall setting, you can see the HBX sensor will turn on the snowmelt system much later than a conventional sensor. This results in huge savings each snow season if your system can turn on later and turn off sooner.

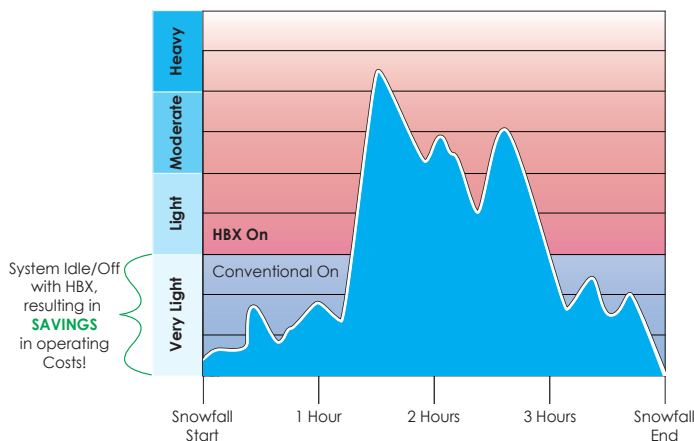

TECHNICAL DATA & DIMENSIONS

Specifications:

- 3 x Thermistor Input (10K Ohm)
- 1 x Demand Input Signal
- 3 x Relay Outputs (240VAC 5A) Dry Contacts
- 1 x 2Amp Dry Contact
- Input: 120VAC +/- 10% 60Hz 15A Max
- FCC ID: 2AHMR-ESP12S

Weight:

0.408Kg

Dimensions:

121mm W x 188mm H x 66mm

ETL Listings:

- Meets CSA C22.2 No. 24
- Meets UL Standard 873
- ETL Control No. 3068143

Storage:

50°F to 104°F (10°C to 40°C)

RF Info:

- Contains IC: 8169A-G2M5477
- Contains FCC ID: U3O-G2M5477
- WiFi: 2.4Ghz network only

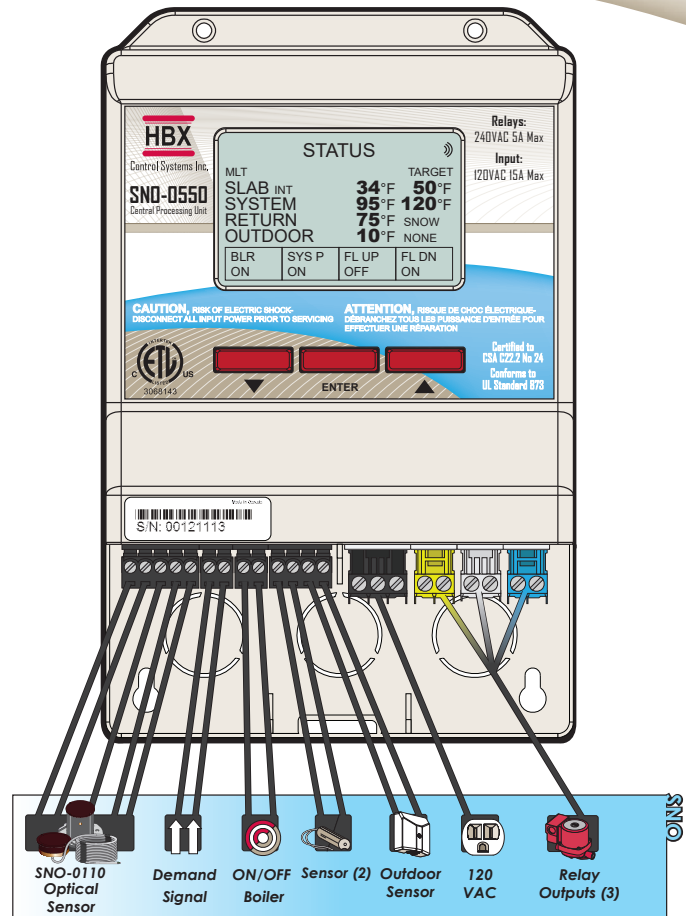

DIMENSIONS

Side View

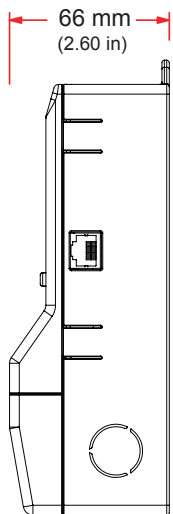

Front View

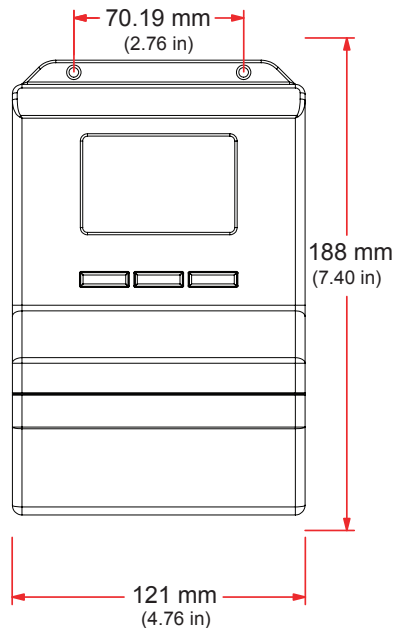

Rear View

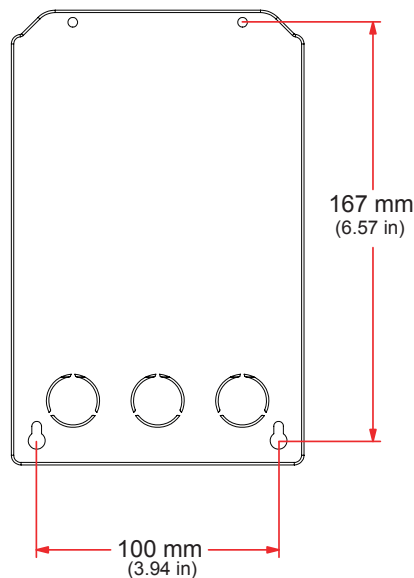

Top View

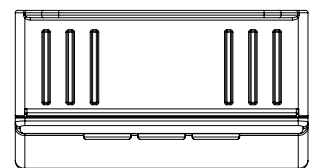

Bottom View

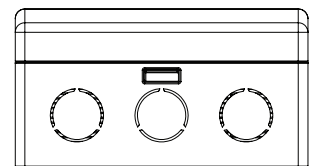

WIRING AND INSTALLATION

Wiring

All thermistor wiring must be with a minimum of 18AWG wire at a maximum of 500ft.

1, 2, 3, 4, 5: Snowmelt Optical Sensor

Connection order: Green - Contact 1, Red - Contact 2, White - Contact 3, Black - Contact 4, Shield - Contact 5.

6, 7: Demand Signal

Apply snow melt demand from a dry contact. For force melt demand, use a momentary switch.

8, 9: Boiler Contacts

Boiler enable contact.

Sensor Inputs

10, 13: System supply sensor- Brass strap on sensor, to be installed on the supply to the snow melt manifold

11, 13: Return sensor - Brass strap on sensor, to be installed on the return from the snow melt manifold

12, 13: Outdoor sensor - OUT-0100 install on the north wall out of the sun and away from any exhaust vents. Ensure that the hole for the wire is sealed.

14, 15, 16: Power Supply

Apply 120 VAC to power unit.

17, 18: Relay 1

Generally used as a system pump.

19, 20: Relay 2

Generally used as floating action valve up (Open).

21, 22: Relay 3

For injection mixing, generally used as injection pump. For floating action mixing, generally used as floating action valve down (Closed).

 (Relays 1, 2 and 3 are dry contacts and rated for a maximum of 5A.)

 Please ensure no power is applied to pins 1 - 5 and 10 - 13.

 When the desired sensor location is more than 100 feet from the SNO-0550, the sensor wire can be extended using 18 AWG shielded cable (up to 200 feet). The cable can be shortened if required.

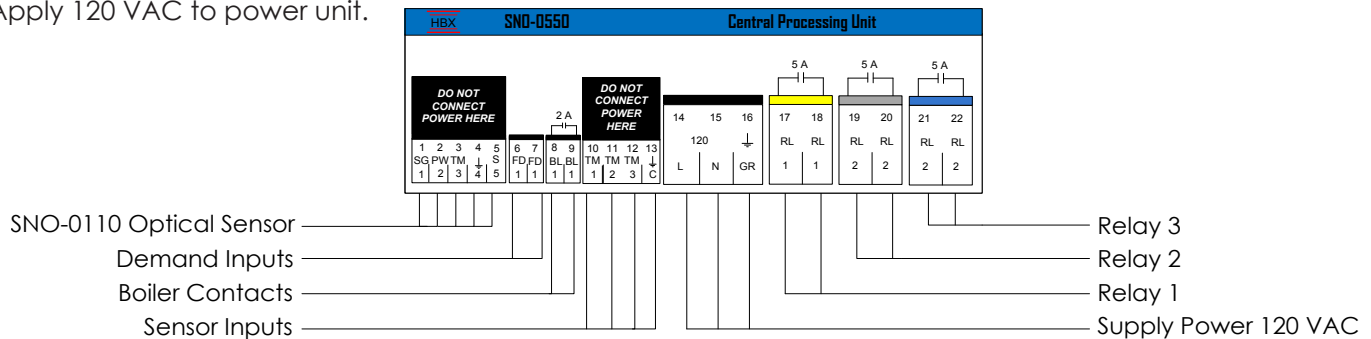

Installation

The SNO-0550 is designed to be wall mounted or installed in a separate electrical enclosure. The unit should be mounted inside and protected from falling water and high humidity conditions. With all the covers in place it is designed to protect any individual from accidental electrical shock. It is not suitable for installation in hazardous locations and should not be placed close to any electromagnetic fields.

- Identify the four mounting holes on the SNO-0550, mark on the wall the desired location of mounting.
- Pre-drill, anchor and fasten four screws for mounting.
- Hang SNO-0550 and fasten tight to desired locations
- Complete wiring connections in accordance with terminal locations.

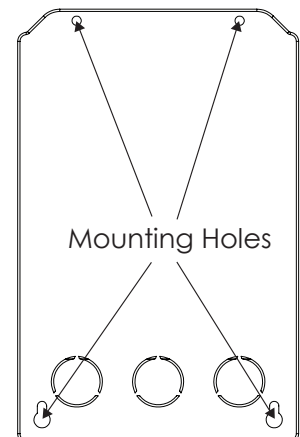

Status Screen

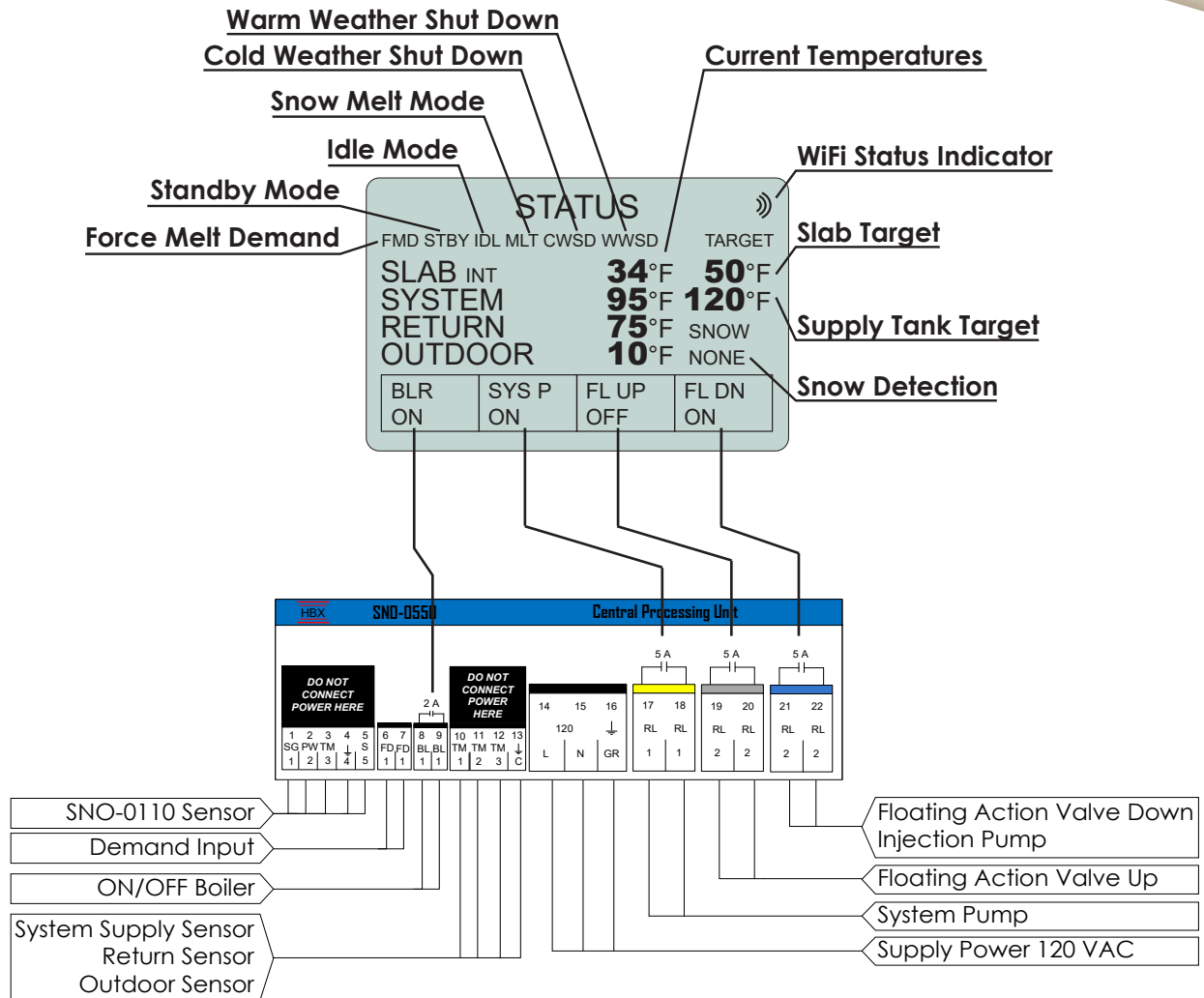

SENSOR ERRORS



HTR-LOWC: Low current is being drawn into the sensor and will not sense snow. Check the wiring of the control. Refer to testing procedure on page 23, and inspect the SNO-0110 Sensor for signs of damage or improper drainage.

Reset control when issue has been corrected to eliminate error code.



HTR-FAULT: High current is being drawn into the sensor and will not sense snow. Screen will flash orange, and fuse in control will trip. Check the wiring of the control. Refer to testing procedure on page 23, and inspect the SNO-0110 Sensor for signs of damage or improper drainage.

Reset control when issue has been corrected to eliminate error code.

STATUS & MODE DESCRIPTIONS

ON: Control is awaiting signal from optical sensor or Forced Melt Demand from user.

OFF: Control is in **WWSD/CWSD** or no demand is present (Pins 6-7) when in **DEMAND** mode **STANDBY/IDLE** (See Page 11)

MELT: Control is **ON** and snow was detected by the sensor higher then the intensity setting.

IDLE: Control is **ON** and maintaining the slab at the idle temperature until snow is detected by optical sensor or forced melt demand is given by user.

STANDBY: Control is **ON** but not maintaining a slab temperature. Control will remain **ON** until snow is detected by optical sensor or forced melt demand is given by user.

ANTICIPATE: Control will be **ON** in **STANDBY** or **IDLE** for the amount of time determined by the user in **ANTICIPATE DAYS**.

ANTICIPATE DAYS: If snow is detected during this time control will go in to melt mode. Otherwise the control will be **OFF** after **ANTICIPATE DAYS** has elapsed.

FORCE MELT: When control is **ON** and awaiting snow detection by optical sensor, if demand is given (PINS 6-7) control will go into melt mode. Pressing **UP** and **DOWN** arrow buttons simultaneously for approximately 10 seconds will also override sensor and force melt mode.

CONTROL SETUP

Multicolour backlit Display

The Multicolour Backlit Display is one of the key features of the HBX Controls stand-alone SNO-0550 Control. Depending on which mode of operation is selected the screen colour will change to indicate information about the status of the system.

Screen Colors

- Light Blue (White) - No Demand/ **OFF**
- Green - Standby Mode
- Dark Blue - Idle Mode
- Red - Melt Mode
- Flashing Orange - Optical Sensor Fault

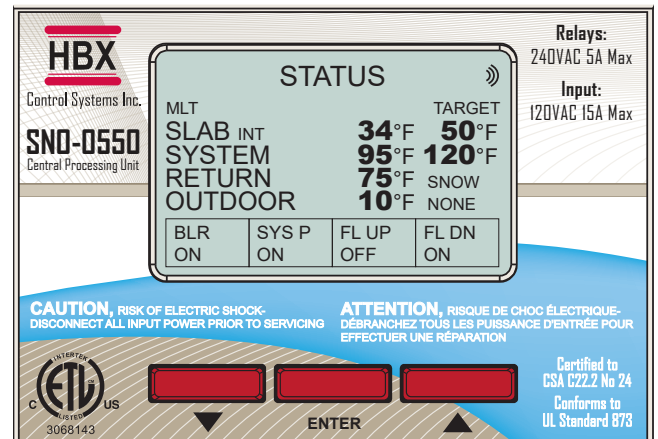

NAVIGATING THE SNO-0550

All programming steps within the SNO-0550 are achieved by using the three buttons (and combination thereof) located below the screen.

The ▼ button is used to scroll down in menu screens and decrease a value within specific options.

The ▲ button is used to scroll up in menu screens and increase a value in specific options.

The **ENTER** button is used to access the setpoint menu and select a setting.

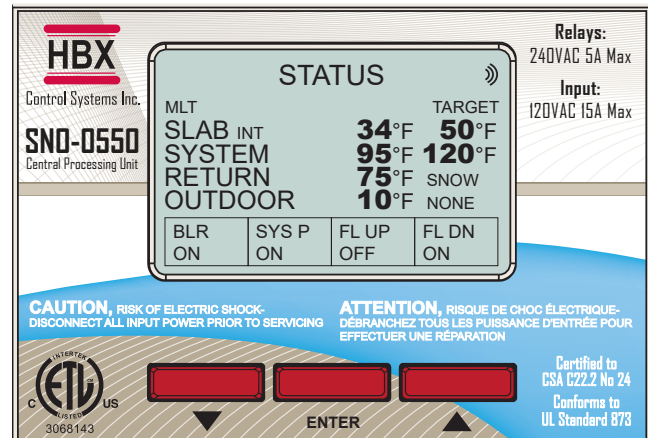

SETUP MENU

The SETUP menu is used for entering the design values, as well as assign different control options. To access the setup menu, push the **ENTER** button on the STATUS screen. Use the ▲ or ▼ buttons to scroll through the various settings.

To select a parameter, align the cursor arrow ▶ with the desired parameter and press the **ENTER** button. the arrow will become solid ►, which indicates that a parameter has been selected.

Adjust the setting to the desired value with the ▲ or ▼ buttons. Once the correct value is set, push the **ENTER** button. This will deselect the parameter.

To go to the previous screen, push and hold the **ENTER** button. If the SETUP menu is left for more than 90 seconds, the display will change to the STATUS screen and the control will resume operation. During SETUP, the control is not operating.

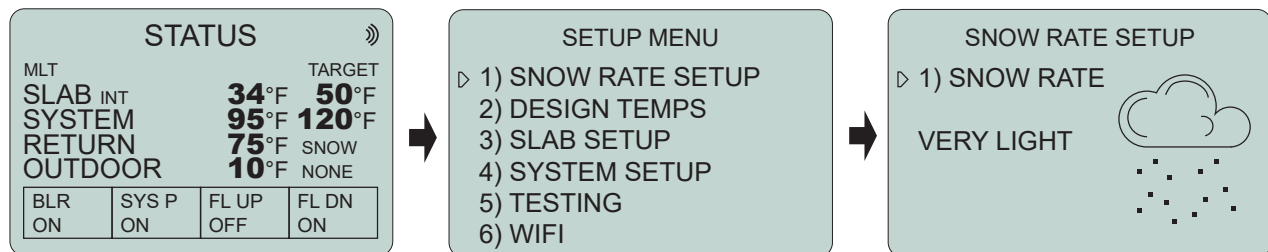

Holding the ▲ and ▼ buttons on the STATUS screen simultaneously for 10 seconds will put the control into forced melt demand.

PROGRAMMING GUIDE

1) SNOW RATE

SETUP MENU

- ▶ 1) SNOW RATE SETUP
- 2) DESIGN TEMPS
- 3) SLAB SETUP
- 4) SYSTEM SETUP
- 5) TESTING
- 6) WIFI

Snow Rate Setup

This setting is used to configure the snowfall rate at which your system will go into **MELT** mode

SNOW RATE SETUP

SNOW RATE SETUP

- ▶ 1) SNOW RATE

VERY LIGHT

Very Light (Default)

This will set the control to trigger **MELT** mode when a Very Light snowfall is detected.

SNOW RATE SETUP

- ▶ 1) SNOW RATE

LIGHT

Light

This will set the control to trigger **MELT** mode when a Light snowfall is detected.

SNOW RATE SETUP

- ▶ 1) SNOW RATE

MODERATE

Moderate

This will set the control to trigger **MELT** mode when Moderate snowfall is detected.

SNOW RATE SETUP

- ▶ 1) SNOW RATE

HEAVY

Heavy

This will set the control to trigger **MELT** mode when Heavy snowfall is detected.

Optical Sensor Melt Trigger Sensitivity



2) DESIGN TEMPERATURE

SETUP MENU

- 1) SNOW RATE SETUP
- ▶ 2) DESIGN TEMPS
- 3) SLAB SETUP
- 4) SYSTEM SETUP
- 5) TESTING
- 6) WIFI

Design Temperature Setup

This setting allows you to customize each design temperature for your system

DESIGN TEMPERATURE SETUP

DESIGN TEMPERATURES

- ▶ 1) DELTA T **25°F**
- 2) MIN SYSTEM **50°F**
- 3) MAX SYSTEM **120°F**
- 4) WWSD **40°F**
- 5) CWSD **0°F**
- 6) °C OR °F °F

Delta T

Set this temperature to the Δt you would like in the system. This will calculate the system target. The target is calculated by using system supply and system return temperatures: $System\ Target = System\ return + System\ \Delta t$

(2°F to 60°F) Default: 25°F

DESIGN TEMPERATURES

- 1) DELTA T **25°F**
- ▶ 2) MIN SYSTEM **50°F**
- 3) MAX SYSTEM **120°F**
- 4) WWSD **40°F**
- 5) CWSD **0°F**
- 6) °C OR °F °F

Minimum System Temperature

Set this to the minimum temperature you would like your entering water temperature in the slab to be. This is for the low temperature system loop.

(20°F to 180°F) Default: 50°F

DESIGN TEMPERATURES

- 1) DELTA T **25°F**
- 2) MIN SYSTEM **50°F**
- ▶ 3) MAX SYSTEM **120°F**
- 4) WWSD **40°F**
- 5) CWSD **0°F**
- 6) °C OR °F °F

Maximum System Temperature

Set this to the maximum temperature you would like your entering water temperature in the slab to be. This is for the low temperature system loop.

(20°F to 180°F) Default: 120°F

DESIGN TEMPERATURES

- 1) DELTA T **25°F**
- 2) MIN SYSTEM **50°F**
- 3) MAX SYSTEM **120°F**
- ▶ 4) WWSD **40°F**
- 5) CWSD **0°F**
- 6) °C OR °F °F

Warm Weather Shut Down

This is used to set the temperature in which the SNO-0550 will go into WWSD. If the outdoor temperature rises above this temperature, the control will turn **OFF**. In WWSD the boilers and all pumps will shut off, and slab temperature will not be maintained.

(2°F to 55°F) Default: 40°F

DESIGN TEMPERATURES

- 1) DELTA T **25°F**
- 2) MIN SYSTEM **50°F**
- 3) MAX SYSTEM **120°F**
- 4) WWSD **40°F**
- ▶ 5) CWSD **0°F**
- 6) °C OR °F °F

Cold Weather Shut Down

This is used to set the temperature in which the SNO-0550 will go into CWSD. If the outdoor temperature dips below this temperature, the control will turn **OFF**. In CWSD the boilers and all pumps will shut off, and slab temperature will not be maintained.

(-40°F to 40°F) Default: 0°F

DESIGN TEMPERATURES

- 1) DELTA T **25°F**
- 2) MIN SYSTEM **50°F**
- 3) MAX SYSTEM **120°F**
- 4) WWSD **40°F**
- 5) CWSD **0°F**
- ▶ 6) °C OR °F °F

Celsius or Fahrenheit Setup

Toggle this setting to set the control to display values in either Celsius or Fahrenheit.

3) SLAB SETTINGS

SETUP MENU

- 1) SNOW RATE SETUP
- 2) DESIGN TEMPS
- ▶ 3) SLAB SETUP
- 4) SYSTEM SETUP
- 5) TESTING
- 6) WIFI

Slab Setup

This setting is used to configure your slab options.

SLAB SETUP

SLAB SETUP

- ▶ 1) IDLE TEMP **20°F**
- 2) MELT TEMP **50°F**
- 3) MELT TIME **3H**
- 4) SENSOR LOC INT

Idle Temperature

This is the slab setpoint when there is no snowfall present, and the control is operating between the WWSD and CWSD parameters.

(-39°F to 80°F) Default: 20°F



To turn Idle Temperature OFF, set temperature below -39 °F or above 80 °F.

SLAB SETUP

- 1) IDLE TEMP **20°F**
- ▶ 2) MELT TEMP **50°F**
- 3) MELT TIME **3H**
- 4) SENSOR LOC INT

Melt Temperature

This is the slab setpoint when there is a snowfall detected by the optical sensor, or is manually put into a Forced Melt.

(20°F to 100°F) Default: 50°F

SLAB SETUP

- 1) IDLE TEMP **20°F**
- 2) MELT TEMP **50°F**
- ▶ 3) MELT TIME **3H**
- 4) SENSOR LOC INT

Melt Time

This setting allows for the system to stay on even after no snow is present. This will melt any residual snow that has accumulated and not melted. This time is also used when a force melt demand is given. Once a force melt demand is given the control will stay in **MELT** mode for this amount of time.

(1H to 99H) Default: 3H

SLAB SETUP

- 1) IDLE TEMP **20°F**
- 2) MELT TEMP **50°F**
- 3) MELT TIME **3H**
- ▶ 4) SENSOR LOC INT

Sensor Location

Set this to **INT** when the Snow/ Ice Optical Sensor is mounted in-slab, or set to **REM** when mounted remotely.

(INT or REM) Default: INT

4) SYSTEM SETTINGS

SETUP MENU

- 1) SNOW RATE SETUP
- 2) DESIGN TEMPS
- 3) SLAB SETUP
- ▶ 4) SYSTEM SETUP
- 5) TESTING
- 6) WIFI

System Setup

This setting is used to configure the demand type and mixing settings.

SYSTEM SETUP

SYSTEM SETUP

▶ 1) MIXING	INJECTION
2) DEMAND	FORCE MELT

THIS DEMAND WILL PLACE THE SLAB INTO MELT MODE

Mixing Type

This setting is used to select mixing type.

INJ: PMIp injection pump

FLO: Floating action valve [power open (valve up)/ power close (valve down)]

(FLO and INJ) Default: INJ



If you are not using any mixing these settings do not apply, but still ensure that you connect the return and supply sensors to the SNO-0550 as it will not function without these installed.

SYSTEM SETUP

1) MIXING	INJECTION
▶ 2) DEMAND	FORCE MELT

THIS DEMAND WILL PLACE THE SLAB INTO MELT MODE

Demand Type

This setting is a manual demand by the user. When a demand is given, the control will go into the selected mode. The demand input is located on terminal pins 6-7.

Default: **FORCE MELT**

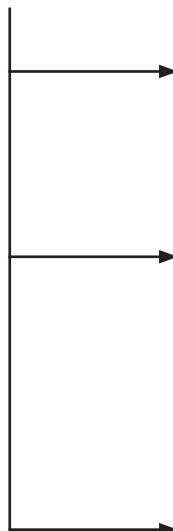

SYSTEM SETUP

1) MIXING	INJECTION
▶ 2) DEMAND	FORCE MELT

THIS DEMAND WILL PLACE THE SLAB INTO MELT MODE

FORCE MELT: This demand type allows the control to run automatically. When a momentary manual demand from pins 6-7 or via the app is given, the control will go into **MELT** mode. When no manual demand is present, control will go into **IDLE** mode and await snow melt detection by the optical sensor.

SYSTEM SETUP

1) MIXING	INJECTION
▶ 2) DEMAND	STANDBY/IDLE

THIS DEMAND WILL PLACE THE SLAB INTO STANDBY OR IDLE MODE

STANDBY/IDLE: When a manual demand is given from pins 6-7 or via the app, the control will **IDLE** and await snow detection by the optical sensor. Once snow is detected and it runs through the melt cycle the control will reset into the **IDLE** state as long as the demand is still present. If the Demand is removed prior to it initiating a **MELT** mode, then it will resort back into a **STANDBY/OFF** state. When no manual demand is present, the control will be in a **STANDBY/OFF** state.

SYSTEM SETUP

1) MIXING	INJECTION
▶ 2) DEMAND	ANTICIPATE
3) ANTICIPATE DAYS	2

THIS DEMAND WILL PLACE THE SLAB INTO MELT MODE

ANTICIPATE: When a momentary manual demand is given from pins 6-7 or via the app, the control will **IDLE** for the amount of days selected in **ANTICIPATE DAYS** and await snow detection by the optical sensor. When the time has expired or it has finished a **MELT** cycle the control will revert into a **STANDBY/OFF** state. When no manual demand is present, control will be in a **STANDBY/OFF** state.

SYSTEM SETUP

1) MIXING	INJECTION
2) DEMAND	ANTICIPATE
▶ 3) ANTICIPATE DAYS	2

THIS DEMAND WILL PLACE THE SLAB INTO STANDBY OR IDLE MODE FOR 2 DAYS

ANTICIPATE DAYS: This setting will determine the length of time control will be on in **ANTICIPATE** mode.

(1 to 7) Default: 2

5) TESTING

SETUP MENU

- 1) SNOW RATE SETUP
- 2) DESIGN TEMPS
- 3) SLAB SETUP
- 4) SYSTEM SETUP
- ▶ 5) TESTING
- 6) WIFI

Testing Setup

This setting is used to test and view functionality of the control.

TESTING SETUP

TESTING

- ▶ 1) CONTROL INFO
- 2) FUNCTION TEST ON
- 3) RELAY 1 OFF
- 4) RELAY 2 OFF
- 5) RELAY 3 OFF
- 6) RELAY 4 OFF

Control Information

This setting will display processing information about the control and optical sensor.

Please see troubleshooting guide (page 24) for more information.

TESTING

- 1) CONTROL INFO
- ▶ 2) FUNCTION TEST ON
- 3) RELAY 1 OFF
- 4) RELAY 2 OFF
- 5) RELAY 3 OFF
- 6) RELAY 4 OFF

Function Test

This setting will allow the user to pre-test the control during setup. It will set the outdoor temperature to 10 °F and the system temperature to 80 °F so the system will test in warmer months.

TESTING

- 1) CONTROL INFO
- 2) FUNCTION TEST ON
- 3) RELAY 1 OFF
- 4) RELAY 2 OFF
- ▶ 5) RELAY 3 ON
- 6) RELAY 4 OFF

Relay Test

These settings will test each relay in the control in order to ensure correct operation. The user is able to test each relay individually. In order to test, select the desired relay by pressing **ENTER**. The relay can be toggled on and off by pressing the ▲ or ▼ buttons.

WIFI SETUP

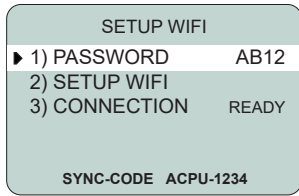

Password

This is the password for the device, selecting this option allows you to change the device's password to secure the privacy of this device when needed.

No: Password will remain the same.

Yes: The control will randomly generate a new password.

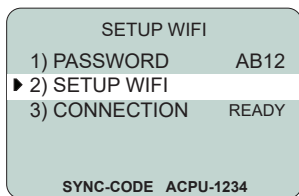
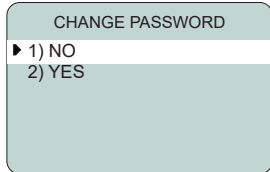

Setup WIFI

SSID: This will display the connected network or can also be selected to manually enter a network

1) Network name location

2) NEXT: When inputting the password select this to input the next letter or number in the sequence of the password

3) DELETE: When inputting the password use this to delete the letter or number, this will return you to the previous sequence

4) DONE: When you have correctly inputted the password select done to return to the previous screen

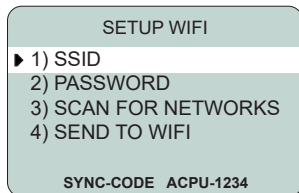

Password: This will display the password for the network, select this to manually enter the password

1) Password location

2) NEXT: When inputting the password select this to input the next letter or number in the sequence of the password

3) DELETE: When inputting the password use this to delete the letter or number, this will return you to the previous sequence

4) DONE: When you have correctly inputted the password select done to return to the previous screen

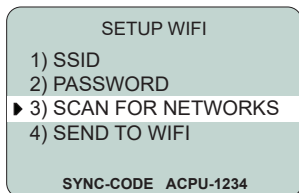
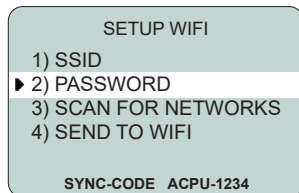

Scan for Networks: Selecting this will automatically scan for all available networks

SSID: press the enter button then using the up and down keys select your network, once it is selected hold the middle key for 2 seconds to return to the previous screen.

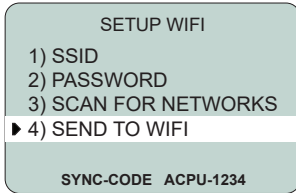

Send to WIFI: Select this once you have correctly entered the password to the selected Network. The control will send the SSID and password upon which it will automatically connect. Press and hold the enter button for 2 seconds to return to the WIFI SETTINGS screen. CONNECTION should change from WIFI to SERVER. Once this happens the SNO-0550 is now connected to the network.

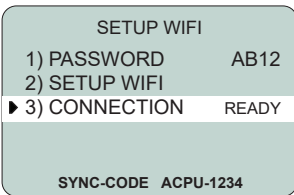

Connection

This option displays the current Wi-Fi connection status.

Ready: Awaiting for Wi-Fi setup. Control is not connected to a Wi-Fi internet network.

Wi-Fi: The control is connected to a Wi-Fi network, but unable to communicate with our server, ensure that PORT 1314 is open

Server: The control is connected to a Wi-Fi network and is communicating with the ThermoLinX server. You can now add the device to the ThermoLinX App.

Once connected, the SNO-0550 control will display a constant Wi-Fi Symbol on the top right corner of the main status screen, and in the Wi-Fi menu Connection will say SERVER.

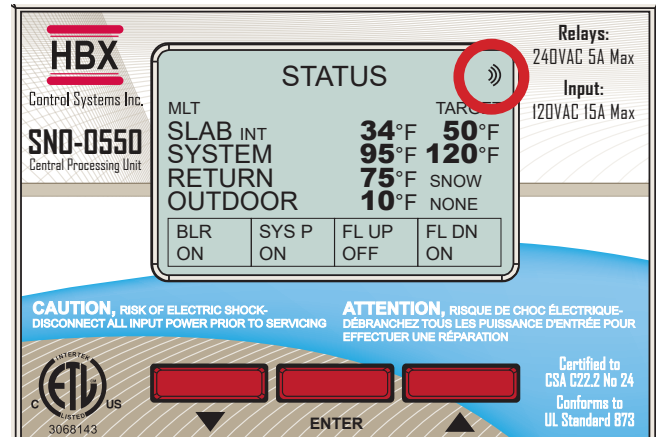

ADDING DEVICES

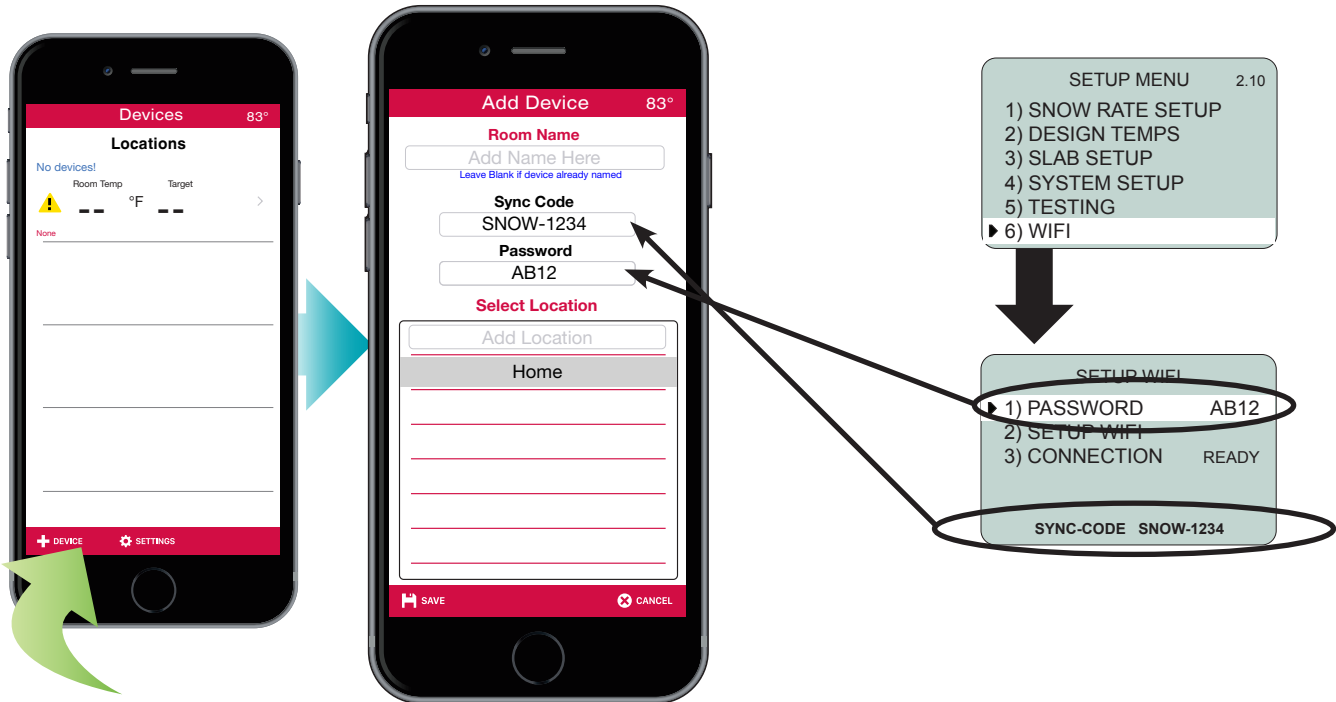

Adding Devices to the HBX Thermolinx App

1. On the home screen, select "+ Device".
2. Add the name of your SNO-0550. Leave this option blank if the SNO-0550 itself is already displaying a name.
3. Enter sync code for SNO-0550 Control. The sync code can be found in the Wifi Setup Menu on the SNO-0550.



The first half of the Sync-Code will always be letters, and the second half will always be numbers.

4. Enter password for SNO-0550. The password can be found in the Wifi Setup Menu on the Control.
5. Enter a system location name and select done/enter. (Ex. Home, Office, Cabin, etc.) **This is the name of the system location, not the SNO-0550 you added.**



Symbols and numbers cannot be used in location name

6. After you have entered the system location name, select the location so it is highlighted, and select save.

HBX APP FUNCTIONALITY

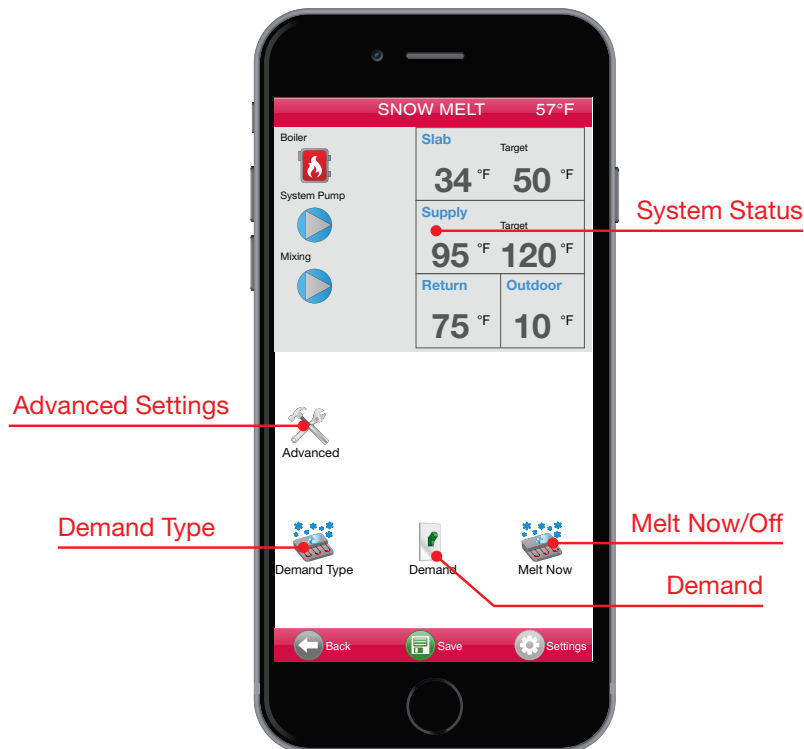

1. Demand Type

This setting is used to determine what the slab does when a demand is given to the control:



Force Melt: When a demand is given the control will go into MELT Mode. When no demand is given, the optical sensor will actively look for snow to trigger a melt demand.

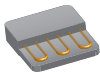

Standby/Idle: When a demand is given, the control will turn on and await snow detection by the optical sensor or Force Melt demand by user. When no manual demand is present, control will be in an OFF state.



Anticipate: When a demand is give the control will turn ON for the amount of time (1-7 days) selected in Anitcipate days (Advanced Settings) and await snow detection by optical sensor or Force Melt Demand by the user.

2. Demand

This allows you to toggle the demand On/Off.

3. Melt Now/Off

This allows you to turn Melt Mode off.

4. Advanced Settings

Allows you to have access to all the settings on the SNO-0550 control including snow rate setup, Design temperatures, Slab and System setup.



A contractor code is required for Advanced Settings. Contact HBX Technical Support for this code.

WIRING DIAGRAMS

1) Snow Melt with Injection Mixing and WiFi Connection

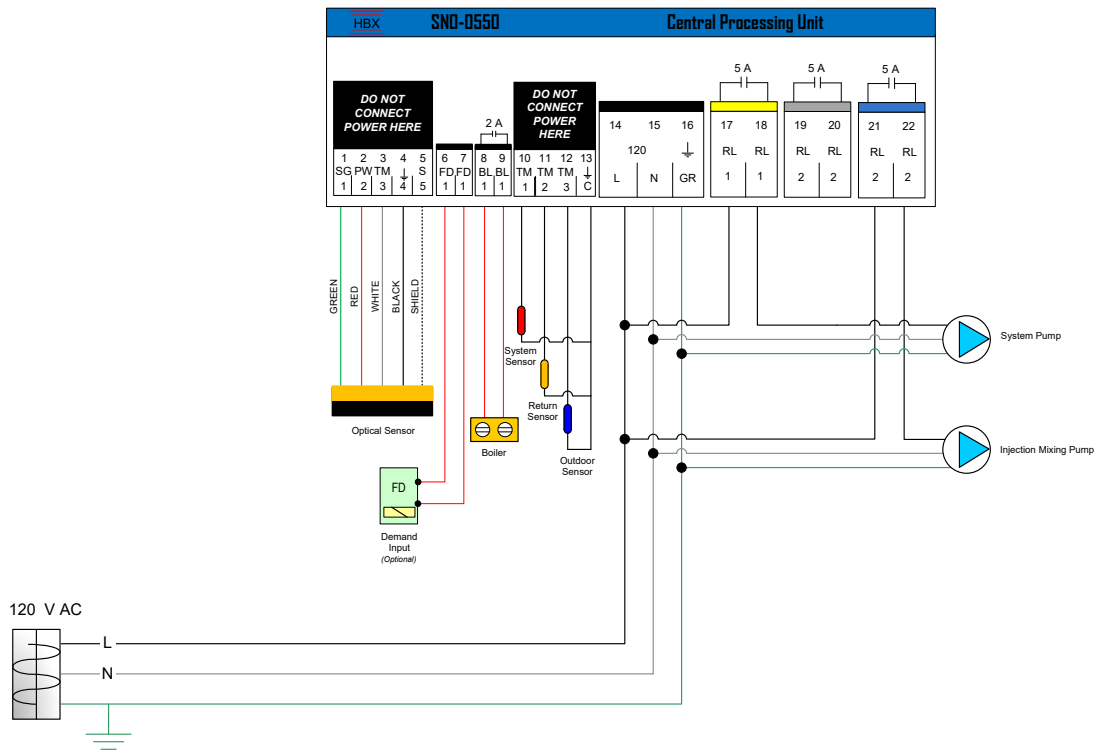

2) Snow Melt with Injection Mixing and Remote Slab Sensor and WiFi Connection

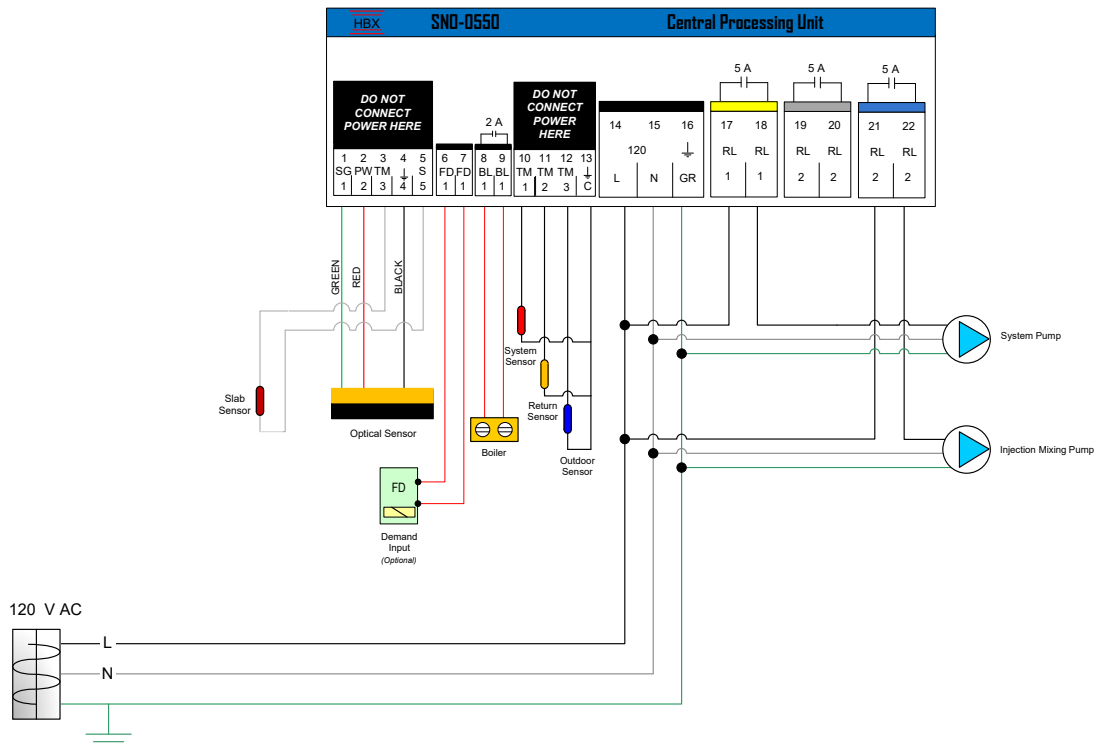

3) Snow Melt with Floating Action Valve Mixing

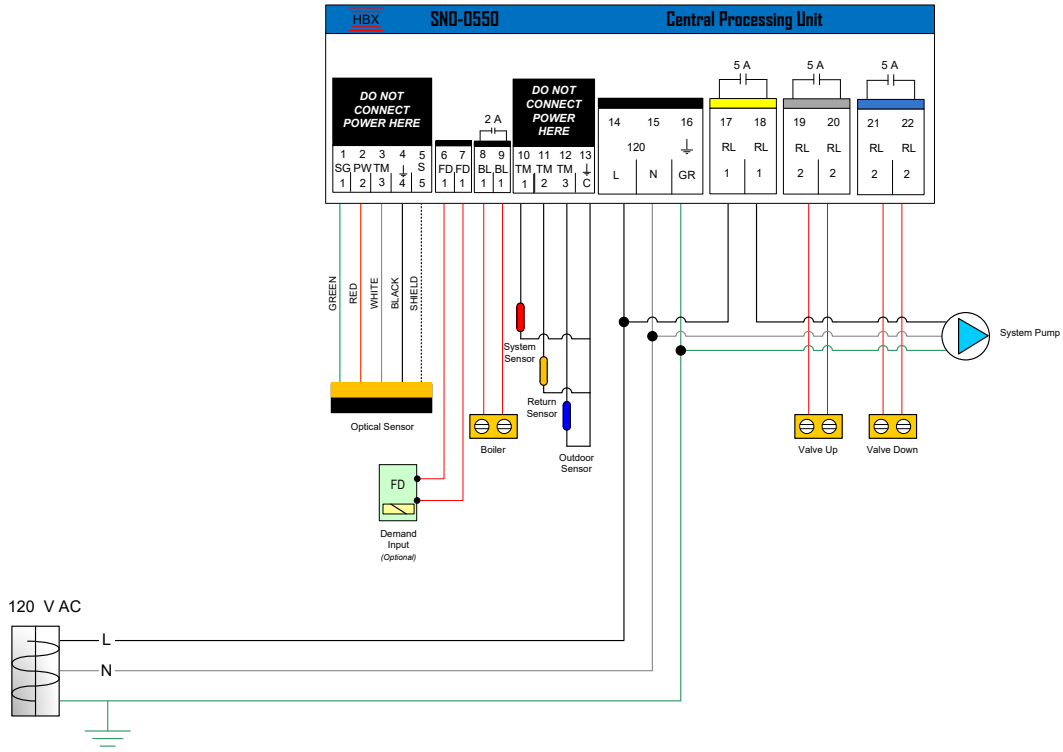

SNO-0550 TROUBLESHOOTING GUIDE

ISSUE	POSSIBLE CAUSES & RESOLUTIONS
Cracked sensor	<ul style="list-style-type: none"> Improper drainage (see pg. 6 SNO-0110 manual.) Improper Installation – too much tension on screw tightening, hammering sensor into socket. Resolution: Replace Sensor
Not melting any snow	<ul style="list-style-type: none"> Sensors not connected (supply, return, outdoor) Damaged sensor: check sensor for cracks or deformations Incorrect settings: Idle temperature is set incorrect, Melt temp is set incorrect, melt time is set incorrect, one or more design temperatures set incorrect. (refer to page 10.) Demand type: set to Standby/Idle or no demand is present Doesn't read slab temperature (sensor) Improper wiring (see page 20.) Sensor location in slab setup is set incorrectly. (See page 10.) Improper sensor physical location
Residual snow is present after demand is not present	<ul style="list-style-type: none"> Max temperature is too low and WWSD is set too high Melt time is set too low. Resolution: Increase time.
Slab temperature Error	<ul style="list-style-type: none"> Incorrect wiring (Shield wire not connected) (See page 20.) Heater has not reached operating temperature. Wait for at least 1 hour after installation. Sensor location in slab setup is set incorrectly. (See page 10.) Damaged sensor: check for cracks or deformations
Doesn't detect snow	<ul style="list-style-type: none"> Damaged sensor: check for cracks or deformations Improper wiring. See page 19 or see SNO-0110 troubleshooting section in manual. Sensor location in slab setup is set incorrectly. (See page 10.) Snow rate setup is set too high. (See page 8.) No demand is present. (See page 11.) WWSD is set too low. (See page 9.) CWSD is set too high. (See page 9.)
Display Screen is Involuntary Switching	<ul style="list-style-type: none"> Display button is stuck
Display Screen is Flickering	<ul style="list-style-type: none"> Up/down/enter button is stuck
Control does not power up	<ul style="list-style-type: none"> Check power supply (120V) Damaged PCB. Resolution: contact HBX Technical Support.

SNO-0550 TROUBLESHOOTING GUIDE

ISSUE	POSSIBLE CAUSES & RESOLUTIONS
Error showing on screen	<ul style="list-style-type: none"> • Sensor is not installed. See wiring on page 19. • Damaged Sensor: check for cracks or deformations (Slab temperature) • Slab setup is incorrect. <i>(See page 10.)</i>
Injection pump not turning on	<ul style="list-style-type: none"> • Check wiring. <i>(See page 20)</i> • Make sure mixing is set to injection. <i>(See page 11.)</i>
Build-up of snow to start melting	<ul style="list-style-type: none"> • Slab Snow rate setup is too high • Delta T is set too low. <i>(See page 8.)</i>
Valve not turning on	<ul style="list-style-type: none"> • Mixing setup needs to be set to floating. <i>(See page 11.)</i> • Check the wiring <i>(see page 20.)</i>
Snow melt is on when no snow is present	<ul style="list-style-type: none"> • Damaged sensor: check for cracks or deformations • Check SNO-0110 troubleshooting manual
Not automatically turning on	<ul style="list-style-type: none"> • No demand present. <i>(See page 11.)</i> • Demand is set to Standby/Idle or Anticipate. <i>(See page 11.)</i>
Force Demand Melt Mode not working	<ul style="list-style-type: none"> • Demand is not in Force Demand Melt. <i>(See page 11.)</i>
System Pump Not Working	<ul style="list-style-type: none"> • Check Wiring <i>(see page 20.)</i>
Boiler is not working	<ul style="list-style-type: none"> • Check wiring: <i>(See page 20.)</i> • Check system design temperatures. <i>(See page 9.)</i>
Slab Temp changes drastically when it comes in or out of WWSD/ CWSD	<ul style="list-style-type: none"> • The optical sensor has a built in heater and when it is installed in the slab. without the Aux. slab sensor the control will minus off approximately 40F/22C off the actual slab temp to accommodate for the internal heater that has now started up. This heater can take up to 1 hour to reach it's setpoint, thus your slab will appear that it is much colder when it first turns on, the opposite is true when it goes into WWSD or CWSD the slab temp will jump by 40F/22C as the control removes the adjustment, and the heater will now slowly cool down which could take up to 1 hour.

TESTING AND TROUBLESHOOTING PROCEDURE

SNO-0550 / SNO-0110 - Testing

1. Thermistor Test

Resistance table for thermistors (outdoor, system)

Temperature		Resistance	Temperature		Resistance	Temperature		Resistance
°F	°C	Ω	°F	°C	Ω	°F	°C	Ω
- 22	- 30	177,000	- 0.4	- 18	86,463	21.2	- 6	44,617
- 18.4	- 28	156,404	3.2	- 16	77,162	24.8	- 4	40,153
- 14.8	- 26	138,482	6.8	- 14	68,957	28.4	- 2	36,182
- 11.2	- 24	122,807	10.4	- 12	61,711	32	0	32,654
- 7.6	- 22	109,075	14	- 10	55,319	35.6	2	29,498
- 4	- 20	97,060	17.6	- 8	49,640	39.2	4	26,686

2. Snowmelt Sensor Test

I. To test the sensor, ensure that the control is in Demand type: Force Melt, and also not in CWSD or WWSO. Put some water or snow on the sensor, and move it around with your hand or a cloth for about 30 seconds to 1 minute. This will trigger a Melt and the control will go through the Melt cycle.

II. Control Info, acceptable parameters for the SNO-0110 Optical Sensor. Control Info is found in the TESTING menu.

Type	Acceptable Parameters
Voltage	11 – 15 VDC
Current	0.585 – 0.599 A
Resistance	19 – 24 OHMS

SENSOR ERRORS



HTR-LOWC: Low current is being drawn into the sensor and will not sense snow. Check the wiring of the control. Refer to testing procedure above, and inspect the SNO-0110 Sensor for signs of damage or improper drainage.

Reset control when issue has been corrected to eliminate error code.



HTR-FAULT: High current is being drawn into the sensor and will not sense snow. Screen will flash orange, and fuse in control will trip. Check the wiring of the control. Refer to testing procedure above, and inspect the SNO-0110 Sensor for signs of damage or improper drainage.

Reset control when issue has been corrected to eliminate error code.

For additional assistance with the SNO-0550, please contact our
Technical Support Department toll free at:

+1 (855) 410-2341

Limited Warranty

HBX Controls warrants each of its products to be free from defects in workmanship and materials under normal use and service for a period of 24 months from date of manufacture or 12 months from date of purchase from an HBX Authorized Dealer, if within the above documented period after date of manufacture.

If the product proves to be defective within the applicable warranty period, HBX on its sole discretion will repair or replace said product. Replacement product may be new or refurbished of equivalent or better specifications, relative to the defective product. Replacement product need not be of identical design or model. Any repair or replacement product pursuant to this warranty shall be warranted for not less than 90 days from date of such repair, irrespective of any earlier expiration of original warranty period. When HBX provides replacement, the defective product becomes the property of HBX Controls.

Warranty Service, within the applicable warranty period, may be obtained by contacting your nearest HBX Controls office via the original Authorized Agent and requesting a Return Material Authorization Number (RMA #). Proof of purchase in the form a dated invoice/receipt must be provided to expedite the issuance of a Factory RMA.

After an RMA number has been issued, the defective product must be packaged securely in the original or other suitable shipping package to ensure that it will not be damaged in transit. The RMA number must be visible on the outside of the package and a copy included inside the package. The package must be mailed or otherwise shipped back to HBX with all costs of mailing/shipping/insurance prepaid by the warranty claimant.

Any package/s returned to HBX without an approved and visible RMA number will be rejected and shipped back to purchaser at purchaser's expense. HBX reserves the right, if deemed necessary, to charge a reasonable levy for costs incurred, additional to mailing or shipping costs.

Limitation of Warranties

If the HBX product does not operate as warranted above the purchasers sole remedy shall be, at HBX's option, repair or replacement. The foregoing warranties and remedies are exclusive and in lieu of all other warranties, expressed or implied, either in fact or by operation of law, statutory or otherwise, including warranties of merchantability and fitness for a particular purpose/application. HBX neither assumes nor authorizes any other person to assume for it any other liability in connection with the sale, installation maintenance or use of HBX Controls products.

HBX shall not be liable under this warranty; if its testing and examination discloses that the alleged defect in the product does not exist or was caused by the purchasers or third persons misuse, neglect, improper installation or testing, unauthorized attempts to repair or any other cause beyond the range of intended use, or by accident, fire, lightning or other hazard.

Limitation of Liability

In no event will HBX be liable for any damages, including loss of data, loss of profits, costs of cover or other incidental, consequential or indirect damages arising out of the installation, maintenance, commissioning, performance, failure or interruption of an HBX product, however caused and on any theory of liability. This limitation will apply even if HBX has been advised of the possibility of such damage.

Local Law

This limited warranty statement gives the purchaser specific legal rights. The purchaser may also have other rights which vary from state to state in the United States, from Province to Province in Canada and from Country to Country elsewhere in the world.

To the extent this Limited Warranty Statement is inconsistent with local law, this statement shall be deemed modified to be consistent with such local law. Under such local law, certain disclaimers and limitations of this statement may not apply to the purchaser. For example, some states in the United States, as well as some governments outside the United States (including Canadian Provinces), may:

Preclude the disclaimers and limitations in this statement from limiting the statutory rights of a consumer (e.g. United Kingdom);

Otherwise restrict the ability of a manufacturer to enforce such disclaimers or limitations; or

Grant the purchaser additional warranty rights which the manufacturer cannot disclaim, or not allow limitations on the duration of implied warranties.

Notes:

Phone: +1 (403) 720-0029 Fax: +1 (403) 720-0054
Email: info@hbxcontrols.com Web: www.hbxcontrols.com

Toll Free Technical Support: +1 (855) 410 2341

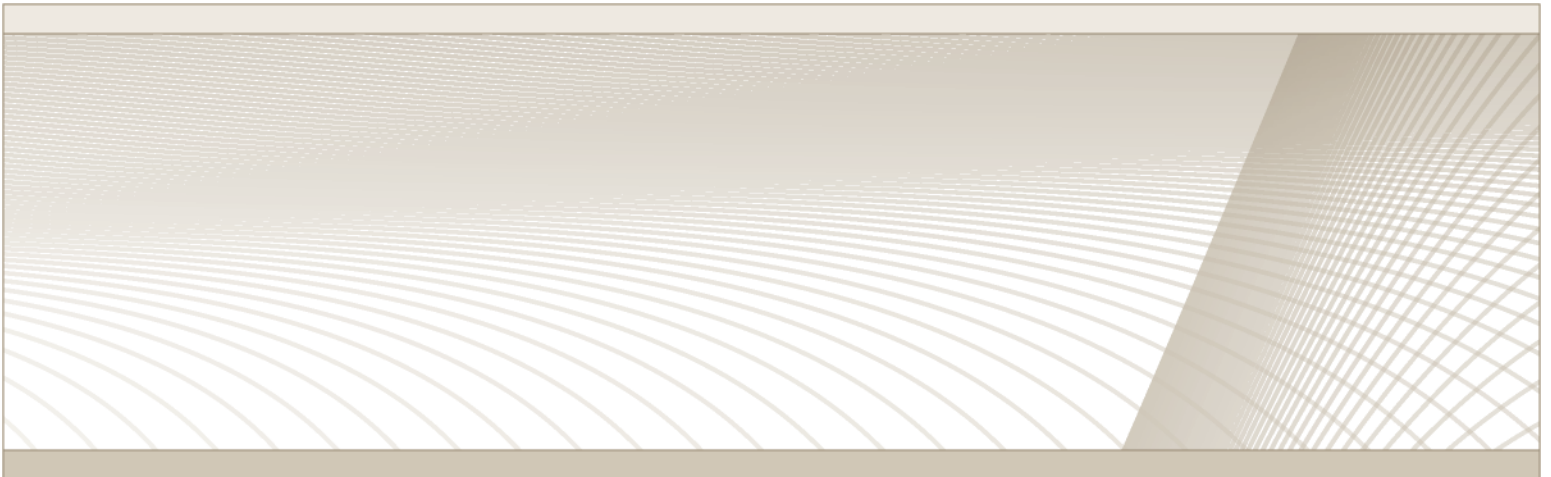

HBX Control Systems Inc.
4516 - 112th Avenue SE
Calgary, AB Canada T2C 2K2

© HBX Control Systems Inc. 2020