



SOLARPLUS





solar systems

solarplus

Applications: expansion vessels for solar systems



Zilmet, an internationally operating company with over 50 years of experience has grown to be the biggest European producer of expansion vessels.

With a complete range of vessels for heating and cold water, ZILMET supplies innovative and specific products, among which are expansion vessels for solar systems as well as stainless steel vessels for harsh environments. The key to success is the completely automatic production lines coupled with an extreme flexibility. Thanks to a marked increase in its range of products, today ZILMET is capable of offering equipment for pressure maintenance, within a complete program of technical installation and in line with the most recent legal norms.

...the first “real” solar vessel was created by ZILMET fifteen years ago.

According to the DIN 4757 standards, ZILMET is certified for solar vessel production since 1996, being the first manufacturer and, therefore, the series SOLARPLUS became the “benchmark of the solar technique”. Our experience in this sector is consolidated by more than 750,000 vessels manufactured and sold over the years. Thanks to its experience, Zilmet is now able to offer a complete system of expansion vessels that satisfy any solar system manufacturer’s specific requirement. Our range includes the SOLARPLUS, SOLARPLUS TM with interchangeable membrane, accessories for fast assembly, VSG additional vessels for temperature decrease, the new SOLARPLUS SAFE that combines a SOLARPLUS vessel with a VSG in line vessel. Brazed plate heat exchangers for solar-system applications are also available.

■ general features

Technical specifications of SOLARPLUS expansion vessel: membrane expansion vessels manufactured according to PED 97/23/EC and EN 13831 standards and suitable for closed solar energy heating systems according to DIN 4757 and EN 12977.

Zilmet developed **ZILAN** membrane for SOLARPLUS expansion vessels. **ZILAN** is an high-temperature membrane, that resists up to 212 °F. **ZILAN** is a membrane made of synthetic rubber, product of decades of experience in installing Zilmet expansion vessels in solar collector energy systems. **ZILAN** synthetic rubber membrane is specifically designed for SOLARPLUS expansion vessels.





The vessel

- completely welded, thus particularly reliable and resistant up to a max pressure of 150 psi.
- painted with epoxy-polyester powder and available in white.
- easy to install

The membrane

The **ZILAN** membrane is the result of a long-term experience in the installation of ZILMET vessels in thermal solar systems, as a consequence:

- Resists to temperatures up to 212 °F
- Resists to various ethylene- or propylene-glycolic mixture
- Membrane has a low gas permeability
- It is DIN 4807-3 certified

In a vessel with fixed membrane the fluid is in direct contact with the inner walls so its temperature cools down without being in contact with the membrane only. We do not have a “thermos effect” which occurs in a vessel with interchangeable membrane where the air between the vessel and solar liquid does not let the fluid lose its heat quickly.

The peculiar structure and the unique features of the SOLARPLUS series guarantee safe and long-lasting performances.

How it works

The expansion vessel must ensure that the solar system can work safely (DIN 4757 and EN 12997) inside the solar circuit, particularly during the stand-by phase.

When inactive, modern solar collectors may reach temperatures up to 392 °F and consequently the fluid within the system can either evaporate or reach levels that can damage all the elements in the solar energy system in time.

In order to be able to resist the highest possible inactivity temperatures, ZILMET has developed **ZILAN** membrane for SOLARPLUS that can withstand up to 212 °F.

In case of high temperatures in the membrane of the expansion vessel, the vessel must be protected by an additional vessel (VDI 6002 directive).

All ZILMET expansion vessels are fit for the installation in the solar system according to DIN 4757 and EN 12977 and they work with a mixture of water and propylene or ethylene glycol. The vessels are tested according to the Pressure Equipment Directive.

The membrane pressure expansion vessel ensures that the system pressure stays within the limits set in the planning phase. The membrane separates the space inside the vessel occupied by the gas and by the solar liquid. The initial pressure of the gas side must be regulated before turning on the system.

The membrane stretches along the gas chamber when the volume of the solar liquid increases because of the heat. Consequently, the available space for the solar fluid increases and the pressure inside the system remains constant at the approved maximum value. But when the volume of the solar liquid decreases because of the cooling, the membrane returns to the initial pre-established pressure value. The available space for the solar liquid decreases and the pressure inside the system remains constant at the approved minimum value.

■ technical and dimensional data

Model	Capacity	Ø Diameter	H Height	E	Connection
	gallons	inches	inches		
ZSP 12	3.2	10.6	10.4	-	3/4"NPT
ZSP 18	4.8	10.6	13.7	-	3/4"NPT
ZSP 25	6.6	11.8	15.4	-	3/4"NPT
ZSP 35 W.F.*	9.2	15.0	14.4	4.9	3/4"NPT
ZSP 50 W.F.*	13.2	15.0	19.8	5.7	3/4"NPT
ZSP 80	21.1	17.7	23.9	5.9	1"NPT
ZSP 105	27.7	19.7	26.2	6.5	1"NPT
ZSP 150	39.6	19.7	35.3	8.5	1"NPT
ZSP 200	52.8	23.6	32.0	8.9	1"NPT
ZSP 250	66.0	24.8	37.7	9.6	1"NPT
ZSP 300	79.3	24.8	43.5	9.6	1"NPT
ZSP 400	105.7	24.8	57.1	9.6	1"NPT
ZSP 500	132.1	29.5	52.8	11.4	1"NPT
ZSP 600	158.5	29.5	61.2	11.4	1"NPT

*with feet

■ material description

Description	Material
shell	carbon steel
connections	carbon steel
membrane	(ZILAN) membrane
color	white epoxy-powder coating
warranty	3 years

■ operating conditions

max. working pressure	150 psi
system operating temperature	14 °F - 230 °F
membrane operating temperature	14 °F - 212 °F
factory precharge	36 psi

■ technical drawings

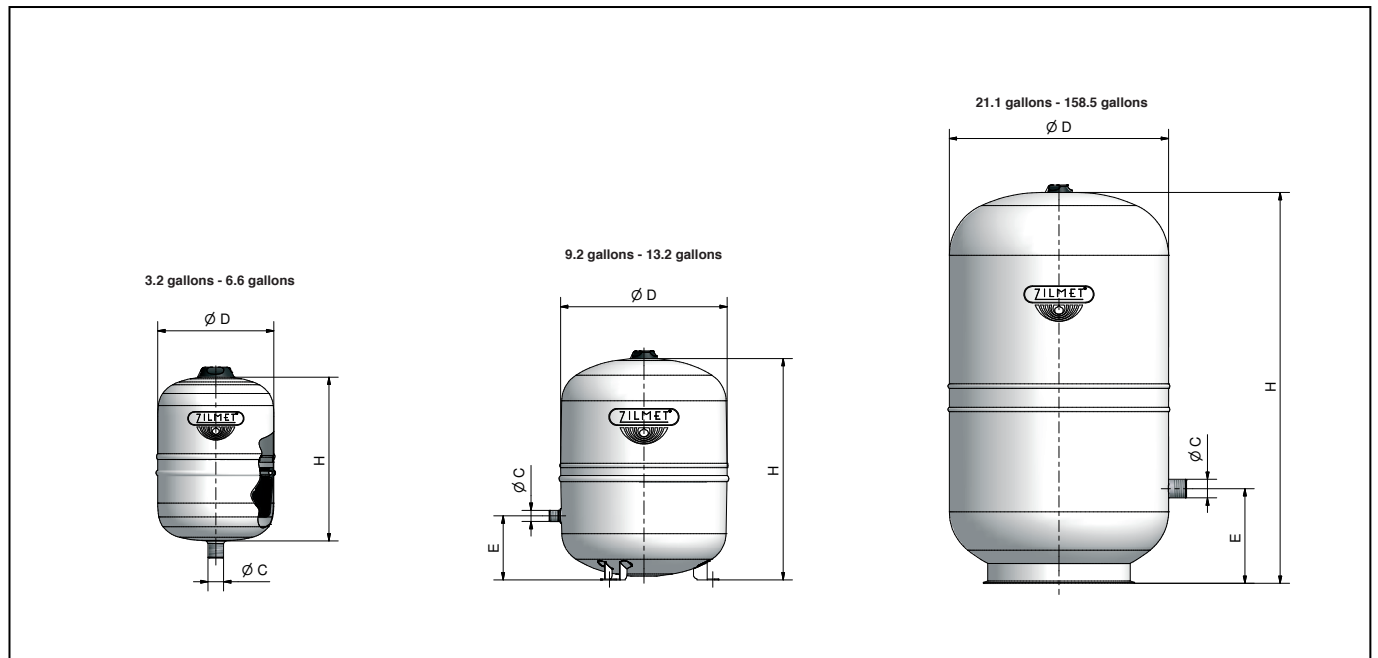



solar systems

solarplus tm Applications: expansion vessels for solar systems.

with replaceable membrane



SOLARPLUS TM is a vertical vessel with a bottom flange to allow membrane replacement whenever necessary. This vessel can handle pressures up to 150 psi.

■ technical and dimensional data

Model	Capacity	Ø Diameter	H Height	Connection
	gallons			
SOLARPLUS TM 12	3.2	10.6	11.7	3/4" NPT
SOLARPLUS TM 18	4.8	10.6	15.4	3/4" NPT
SOLARPLUS TM 24	6.6	10.6	18.1	3/4" NPT
SOLARPLUS TM 80	21.1	17.7	32.7	1" NPT
SOLARPLUS TM 100	26.4	17.7	35.8	1" NPT
SOLARPLUS TM 200	52.8	21.7	48.6	1 1/2" NPT
SOLARPLUS TM 300	79.3	24.8	53.7	1 1/2" NPT
SOLARPLUS TM 500	132.1	29.5	61.4	1 1/2" NPT

■ accessories

Zilmet offers a wide set of accessories for solar systems: these allow quick replacement and safe installation of solar expansion vessels. In particular the solar butterfly valve makes the periodic gas pre-charge checks a matter of minutes

Code	Model	Description	Connection
912508	ZWH B	Universal bracket for wall assembly up to 6.6 gallons	-
912501	ZWH H	Wall support for Solarflex up to 6.6 gallons	-
912507	ZWH HP	Wall support for Solarflex up to 6.6 gallons	-
912503	ZWH M	Fast assembly for 9.2 and 13.2 gallons	-
910105	ZSKV	All metal butterfly solar valve	3/4"
910106	ZSKV	All metal butterfly solar valve	1"
930106	ZSKE	Stop valve	3/4"
944007	ZSP1	Connecting vessel set, 19.7 inches long flexible pipe, 3/4" butterfly solar valve and wall support	



ZWH B



ZWH HP

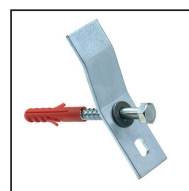

ZWH M



ZSKV



ZSKE

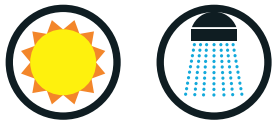

solar systems

additional vessel VSG

Applications: additional vessel for temperature reducing.



According to international regulations and our experience with solar energy, an additional vessel is recommended when the fluid volume between the collector and the expansion vessel is approx 50% or less than the volume (between the expanded diaphragm and the vessel inlet).

This requisite is rarely carried out for heating systems placed on the roofs due to the fact that the piping is short. The additional vessel can protect the membrane from excessive temperatures. The correctly sized additional vessel allows the decrease in the temperature of the solar liquid in the expansion system.

technical and dimensional data

Model	Capacity	Ø Diameter	H Height	E	Connection
	gallons	inches	inches		
VSG 5	1.3	6.3	10.4	-	N°2 x 3/4" NPT
VSG 8	2.1	7.9	13.7	-	N°2 x 3/4" NPT
VSG 12	3.2	10.6	10.4	-	N°2 x 3/4" NPT
VSG 18	4.8	10.6	13.7	-	N°2 x 3/4" NPT
VSG 35	9.2	15.0	14.4	4.9	N°2 x 3/4" NPT
VSG 50	13.2	15.0	19.8	5.7	N°2 x 3/4" NPT
VSG 105	27.7	19.7	26.2	6.5	N°2 x 1" NPT
VSG 200	52.8	23.6	32.0	8.9	N°2 x 1" NPT
VSG 400	105.7	24.8	57.1	9.6	N°2 x 1" NPT

material description

Description	Material
shell	carbon steel
connections	carbon steel
color	white epoxy-powder coating
warranty	5 years

operating conditions

max. operating pressure	150 psi
operating temperature	14 °F - 230 °F

technical drawings

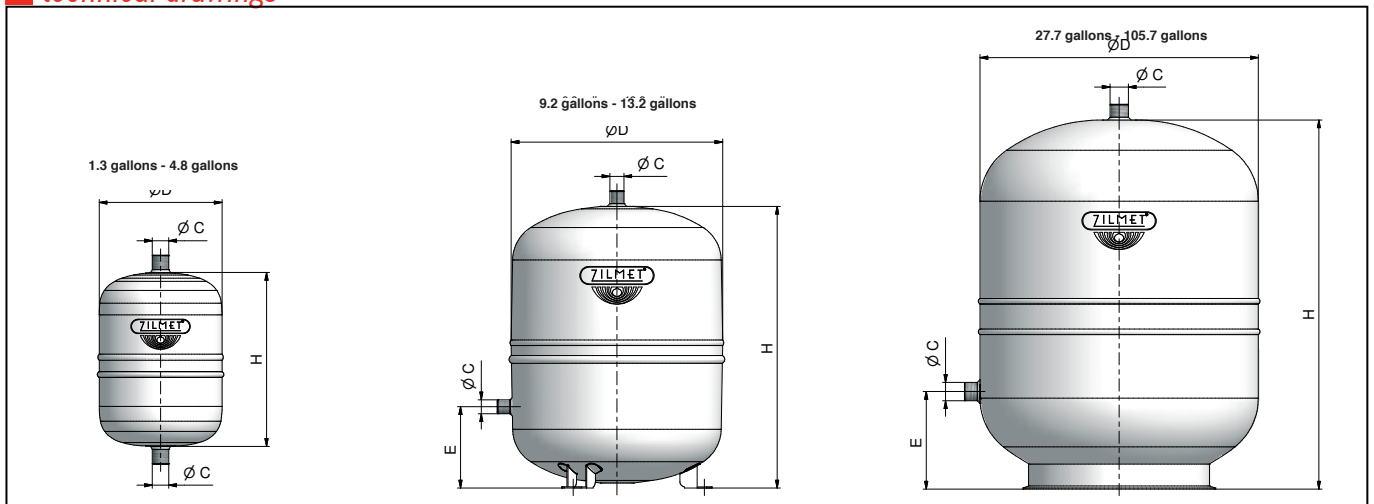

VSG Operation

When there is excessively high temperature in the solar energy system (in some cases even vapor), the hot fluid mixes with the cold stagnant fluid in the VSG vessel. Therefore we have a cooling of the hot fluid through dispersion in the VSG vessel. In this way the membrane of the SOLARPLUS vessel is protected from excessive temperatures.

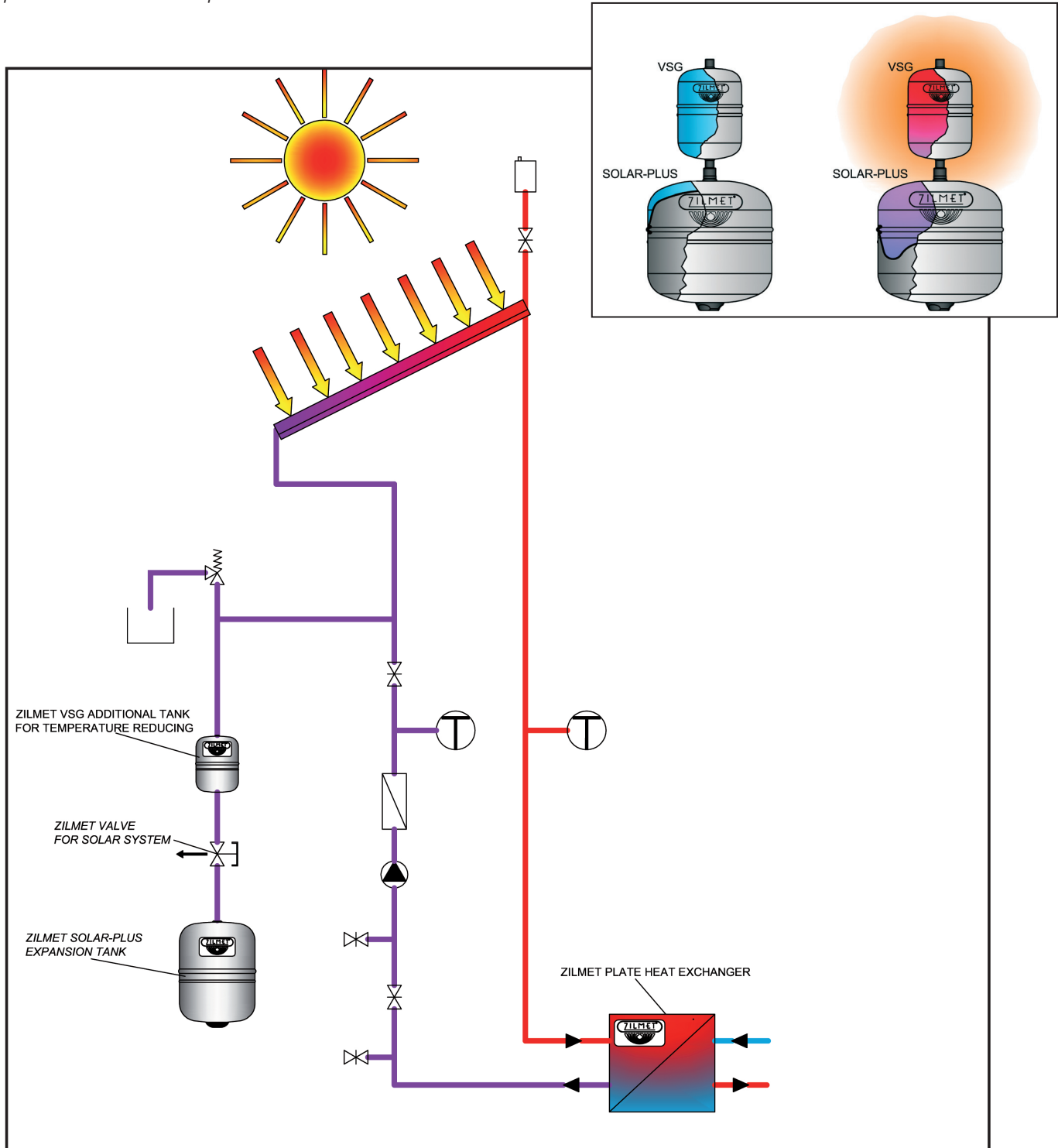

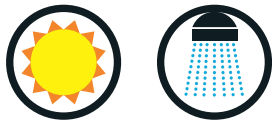

solar systems

solarplus safe

Applications: expansion vessel for solar systems.



Solarplus SAFE: TWO IN ONE

Solarplus SAFE is a completely new product that combines the SOLARPLUS and the solar flow-through in-line vessel in only one vessel. The new expansion vessel is suitable for the use in solar systems according to EN 12976 and EN 12977 (DIN 4757). The SOLARPLUS SAFE expansion vessel ensures safe operation of the solar expansion vessel even in case of excessive temperatures

Advantages

- Less space 40% less space needed
- Less time 50% less installation time required

technical specifications

Approval	Pressure Equipment Directive
Available sizes	SOLARPLUS 4.8, 6.6, 9.2 and 13.2 gallons and Solar in-line tank 1.6, 2.6, 3.2 and 3.9 gallons
Max. operating pressure	150 psi
Operating temperature	14 °F - 230 °F
Max. temperature on the membrane	212 °F
Factory precharge pressure	36 psi
Membrane	 membrane
Color	white epoxy-powder coating
warranty	5 years

technical and dimensional data

Model	Capacity	Ø Diameter	H Height	Ø Connection
	gallons	inches	inches	
SOLARPLUS SAFE	4.8 gal SOLAR + 1.6 gal VSG	10.6	17.8	3/4" NPT
SOLARPLUS SAFE	6.6 gal SOLAR + 2.6 gal VSG	11.8	20.7	3/4" NPT
SOLARPLUS SAFE	9.2 gal SOLAR + 3.2 gal VSG	15.0	18.9	3/4" NPT

technical drawings

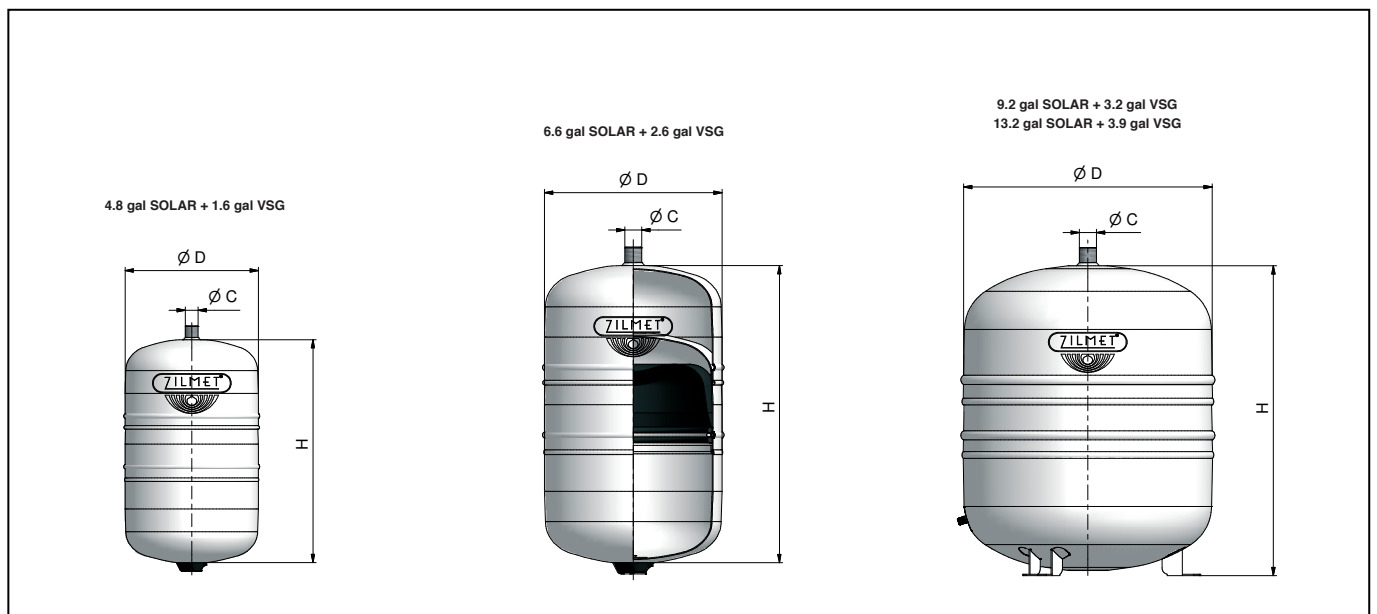

Operations of SOLARPLUS SAFE

The new product line combines the SOLARPLUS with the solar flow-through VSG vessel. Time for installation and space are significantly reduced.

In case of stagnancy of the solar system liquid, the superheated solar liquid pushes the cold solar liquid from the in-line (vessel) chamber into the area of the solar expansion vessel. Therefore, the special membrane of the integrated SOLARPLUS expansion vessel is protected against excessive temperatures.

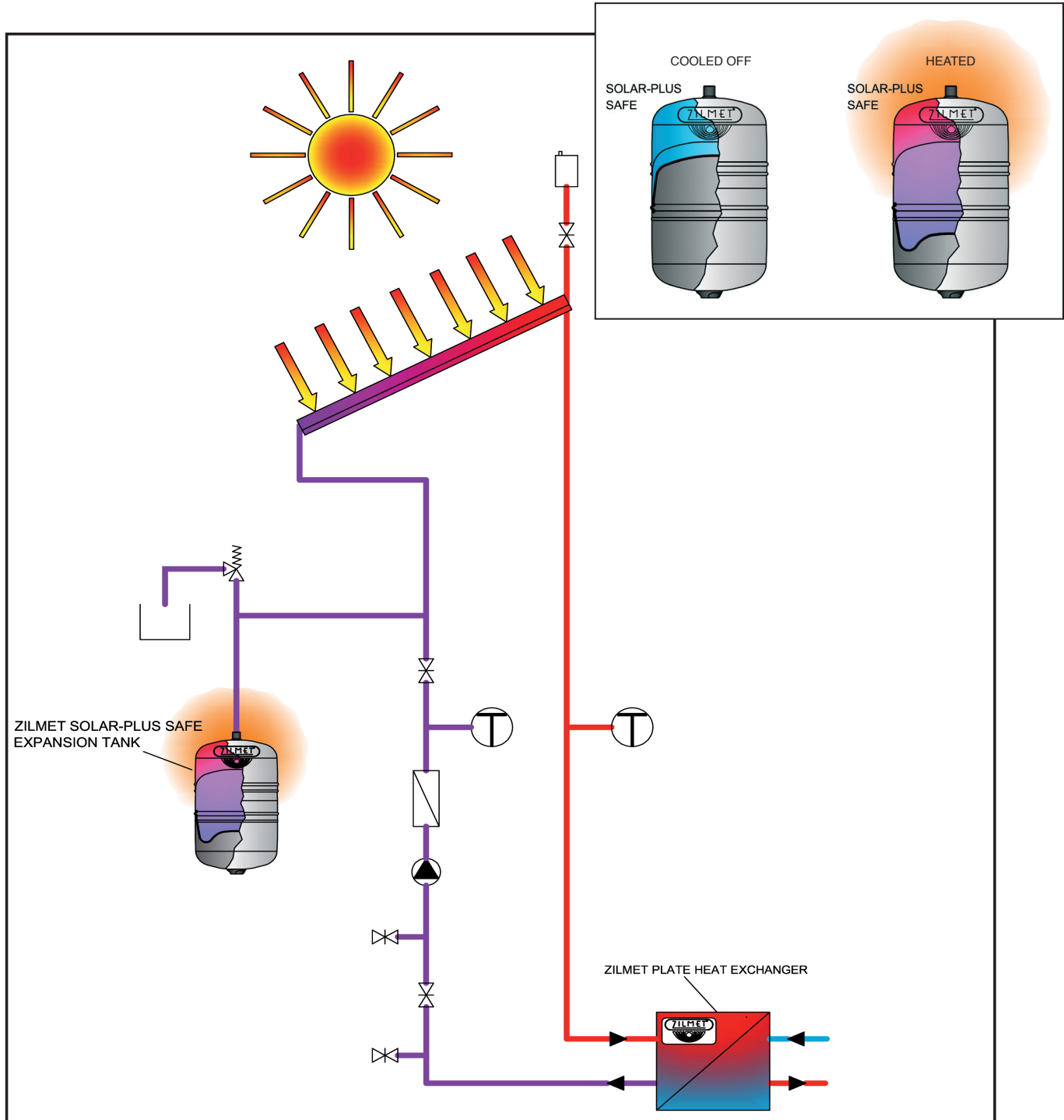

■ sizing an expansion vessel for solar systems

Unlike the expansion vessels for standard central heating systems, sizing the expansion vessels for solar systems requires to consider not only the expansion volume of the solar fluid, but also steam volume due to the evaporation of the solar fluid itself and a proper amount of solar fluid stored in the expansion vessel to compensate reduction in volume due to low working temperatures during winter time.

The formula to size the expansion vessels for solar systems is the following:

$$V_N = [(V_e + V_v + V_d) \times (P_{max} + 14.5)] / (P_{max} - P_{prec})$$

In order to protect the membrane in the expansion vessel from the thermal stress due to high working temperatures, it is advisable to install a properly sized VSG additional vessel.

V_N : nominal volume of the expansion vessel [gallons]

V_e : expansion volume of the solar fluid [gallons]. The expansion volume is calculated as follows:

$$V_e = n \times V_a$$

V_v : amount of solar fluid stored in the expansion vessel [gallons]. The amount of solar fluid is calculated as follows:

$$V_v = 0.02 \times V_a$$

Anyway the amount of solar fluid stored in the expansion vessel must always equal 0.79 gallons at least.

V_d : volume of steam [gallons]. The volume of steam is calculated as follows:

$$V_d = 1.1 \times (V_c + V_t)$$

P_{max} : maximum working pressure of solar system [psi]

P_{prec} : pre-charge pressure of the expansion vessel [psi]

In order to calculate the nominal volume of the expansion vessel, you need to know following data:

V_c : volume of solar collector [gallons]. Given the overall surface of the solar collector, it is possible to estimate the volume of the solar collectors considering: 2.79 gallons/ft² for flat solar collector and 5.70 gallons/ft² for vacuum solar collector.

V_t : volume of solar collector connecting pipes [gallons]

V_a : total volume of the solar system [gallons]. The total volume of the solar system equals the sum of the volume of the solar collector, volume of the heat exchanger, volume of the pipes in the building and the volume of the solar collector connecting pipes.

T_{max} : maximum working temperature of the solar system [°F]

n : expansion coefficient of the solar fluid. Expansion coefficient of solar fluid depends on maximum working temperature and on percentage of glycol in the solar fluid itself: it is possible to calculate the expansion coefficient by using proper tables.

P_{vs} : opening pressure of the safety valve [psi]. It is possible to calculate the maximum working pressure of the solar system as follows :

$$P_{vs} \leq 72.52 \text{ psi, } P_{max} = P_{vs} - 7.25 \text{ [psi]}$$

$$P_{vs} > 72.52 \text{ psi, } P_{max} = 0.9 \times P_{vs} \text{ [psi]}$$

P_{min} : minimum working pressure on the expansion vessel [psi]. Minimum working pressure on the expansion vessel equals the sum of the pressure due to the static head on the expansion vessel and the minimum working pressure of the solar system: the minimum working pressure of the solar system is usually in the range of 7.25-21.76 psi. The pre-charge pressure of the expansion vessel, P_{prec} must equal the minimum working pressure on the expansion vessel, P_{min} .

ATTENTION

The calculation performed by means of the above formula gives only an approximation of the volume needed for the expansion vessel and, anyway, has to be verified by a specialized and authorized technician for keeping into account the real characteristics of the system and of the solar fluid.

■ *sizing of expansion vessels for solar systems - example*

You can consider a solar system with the following characteristics:

Volume of the solar collector, $V_c = 15.85$ gallons

Volume of solar collector connecting pipes, $V_t = 6.6$ gallons

Overall volume of the pipes in the building and of other system components, = **21.13 gallons**

Percentage of glycol in the solar fluid, **40%**

Maximum working temperature of the solar system, $T_{max} = 266$ °F

Opening pressure of the safety valve, $P_{sv} = 87.02$ psi

Minimum working pressure of the solar system, **10.15 psi**

Static head on expansion vessel, **H = 65.61 ft**

You can perform calculations as follows:

$$V_a = 15.85 + 6.6 + 21.13 = 43.58 \text{ gallons}$$

$$V_d = 1.1 \times (15.85 + 6.6) = 24.7 \text{ gallons}$$

$$V_v = 0.02 \times (15.85 + 6.6 + 21.13) = 0.87 \text{ gallons}$$

$$P_{max} = 0.9 \times 87.02 = 78.31 \text{ psi}$$

$$P_{prec} = P_{min} = 29.01 + 10.15 = 39.16 \text{ psi}$$

Given the maximum working temperature and the percentage of glycol in the solar fluid, the expansion coefficient is about 0.09. The expansion volume of the solar fluid is:

$$V_e = (0.09 \times 43.59) = 3.92 \text{ gallons}$$

The nominal volume of the expansion vessel is:

$$V_N = [(3.92 + 24.7 + 0.87) \times (78.31 + 14.5)] / (78.31 - 39.16) = 69.89 \text{ gallons}$$

You have to choose a 79.2 gallons SOLARPLUS expansion vessel

SOLARPLUS and VSG additional vessel choice table

Data mentioned in the table below are indicative for the choice of Solarplus and VSG additional vessel.

Final choice to be verified according to single installation specific characteristics.

Note: data in the table are based on $P_{VS} = 87.20 \text{ psi}$ $T_{max} = 266 \text{ °F}$ and 40% glycole percentage.

Collector surface		64.6 ft ²			108 ft ²			161 ft ²			215 ft ²		
Static height	V _A	Solarplus	VSG	V _A	Solarplus	VSG	V _A	Solarplus	VSG	V _A	Solarplus	VSG	
feet	gallons	gallons	gallons	gallons	gallons	gallons	gallons	gallons	gallons	gallons	gallons	gallons	
16.4	2.7	4.8	1.3	3.7	6.6	1.3	5.1	9.2	3.2	6.6	13.2	3.2	
32.9	3.5	4.8	1.3	4.5	6.6	1.3	5.9	9.2	3.2	7.4	13.2	3.2	
49.3	4.3	6.6	1.3	5.3	9.2	3.2	6.7	13.2	3.2	8.2	21.1	4.8	
65.8	5.1	6.6	1.3	6.1	9.2	3.2	7.5	13.2	3.2	9.0	21.1	4.8	
Collector surface		269 ft ²			323 ft ²			377 ft ²			430.5 ft ²		
Static height	V _A	Solarplus	VSG	V _A	Solarplus	VSG	V _A	Solarplus	VSG	V _A	Solarplus	VSG	
feet	gallons	gallons	gallons	gallons	gallons	gallons	gallons	gallons	gallons	gallons	gallons	gallons	
16.4	7.8	13.2	3.2	11.1	21.1	4.8	12.5	21.1	4.8	14.3	27.7	9.2	
32.9	8.6	21.1	4.8	12.4	21.1	4.8	13.9	27.7	9.2	15.6	27.7	9.2	
49.3	9.4	21.1	4.8	13.7	27.7	9.2	15.2	27.7	9.2	16.9	39.6	13.2	
65.8	10.2	21.1	4.8	15.0	27.7	9.2	16.5	39.6	9.2	18.2	39.6	13.2	
Collector surface		484 ft ²			538 ft ²			592 ft ²			646 ft ²		
Static height	V _A	Solarplus	VSG	V _A	Solarplus	VSG	V _A	Solarplus	VSG	V _A	Solarplus	VSG	
feet	gallons	gallons	gallons	gallons	gallons	gallons	gallons	gallons	gallons	gallons	gallons	gallons	
16.4	15.7	27.7	9.2	17.2	39.6	13.2	18.6	39.6	13.2	20.1	39.6	13.2	
32.9	17.0	39.6	13.2	18.5	39.6	13.2	19.9	39.6	13.2	21.4	39.6	13.2	
49.3	18.3	39.6	13.2	19.8	52.8	26.4	21.3	52.8	26.4	22.7	52.8	26.4	
65.8	19.7	39.6	13.2	21.1	52.8	26.4	22.6	52.8	26.4	24.0	52.8	26.4	
Collector surface		753.5 ft ²			861 ft ²			1076 ft ²			1615 ft ²		
Static height	V _A	Solarplus	VSG	V _A	Solarplus	VSG	V _A	Solarplus	VSG	V _A	Solarplus	VSG	
feet	gallons	gallons	gallons	gallons	gallons	gallons	gallons	gallons	gallons	gallons	gallons	gallons	
16.4	23.0	39.6	13.2	25.9	52.8	26.4	40.9	79.2	26.4	59.4	105.6	52.8	
32.9	24.3	52.8	26.4	27.2	52.8	26.4	43.0	79.2	26.4	61.5	132.0	52.8	
49.3	25.6	52.8	26.4	28.5	66.0	26.4	45.1	105.6	52.8	63.6	132.0	52.8	
65.8	26.9	66.0	26.4	29.8	79.2	26.4	47.3	132.0	52.8	65.7	158.4	52.8	

ATTENTION: The calculation gives only an approximation of the volume needed for the expansion vessel and has to be verified by a specialized and authorized technician for keeping into account the real characteristics of the system and of the used fluid.

plate heat exchangers for solar systems

In addition to the expansion vessels range, Zilmet also produces heat exchangers, brazed-plate and jointed plate, with several operating pressures.

The solar heating, in all its applications, is the ideal way to use Zilmet plate heat exchangers.



North American Headquarters
Zilmet USA
 400 Frenchtown Road
 East Greenwich, RI 02818
 info@zilmetusa.com
 www.zilmetusa.com

Headquarters
 Via del Santo, 242 - 35010 Limena (PD) - Italy
 Tel. +39 049 7664901 • Fax +39 049 767321
 www.zilmet.it
 zilmet@zilmet.it

Production plants - Italy
 Limena (PD) Via del Santo, 242
 Via Visco, 2 • Via Colpi, 30
 Via Tamburin, 15/17
 Bagnoli di Sopra (PD) - Via V Strada, 21/23

Branches
 Zilmet Deutschland GmbH
 www.zilmet.de
 Zilmet USA
 www.zilmetusa.com
 Zilmet UK
 www.zilmet.co.uk