

Installation Instructions

for use by heating contractor



Vitocrossal 300 CU3A



Rigid and Flex Pipe Venting Systems



Product may not be exactly as shown

IMPORTANT

Read and save these instructions for future reference.

Safety, Installation and Warranty Requirements

Please ensure that these instructions are read and understood before commencing installation. Failure to comply with the instructions listed below and details printed in this manual can cause product/property damage, severe personal injury, and/or loss of life. Ensure all requirements below are understood and fulfilled (including detailed information found in manual subsections).

■ Licensed professional heating contractor

The installation, adjustment, service and maintenance of this equipment must be performed by a licensed professional heating contractor.

► Please see section entitled "Important Regulatory and Installation Requirements" in the Installation Instructions.



■ Product documentation

Read all applicable documentation before commencing installation. Store documentation near boiler in a readily accessible location for reference in the future by service personnel.

► For a listing of applicable literature, please see section entitled "Important Regulatory and Safety Requirements" in the Installation Instructions.



■ Carbon monoxide

Improper installation, adjustment, service and/or maintenance can cause flue products to flow into living space. Flue products contain poisonous carbon monoxide gas.

► For information pertaining to the proper installation, adjustment, service and maintenance of this equipment to avoid formation of carbon monoxide, please read these Installation Instructions carefully.



■ Equipment venting

Never operate boiler without an installed venting system. An improper venting system can cause carbon monoxide poisoning.

■ Warranty

Information contained in this and related product documentation must be read and followed. Failure to do so renders the warranty null and void.



■ Advice to owner

Once the installation work is complete, the heating contractor must familiarize the system operator/ultimate owner with all equipment, as well as safety precautions/requirements, shutdown procedure, and the need for professional service annually before the heating season begins.

! WARNING

Installers must follow local regulations with respect to installation of carbon monoxide detectors. Follow manufacturer's maintenance schedule boiler.

How these Installation Instructions are Structured....

These Instructions cover the following venting systems for the Vitocrossal 300 CU3A boilers.

Refer to the section applicable to your application for pertinent installation information.

Before proceeding with the installation, please read sections entitled Safety and General Information. These sections are applicable to all venting systems listed and must be read before commencing the installation.

Information specific to...

- Side Wall Vent Installations (Coaxial) is found in the Side Wall Vent Installation Section starting on page 14.
- Vertical Vent Installations (Coaxial) is found in the Vertical Vent Installation Section starting on page 18.
- Direct Vent Installations (Two-pipe System) is found in the Direct Vent Section starting on page 24.
- Single Pipe Vent Installations (Room Air Dependent) is found in the Single Pipe Venting Section starting on page 42.
- Flexible vent installations on page 58.

	Page
Safety	
Safety, Installation and Warranty Requirements.....	2
How these Installation Instructions are Structured.....	2
Important Regulatory and Installation Requirements.....	6
Operation with balanced flue using coaxial vent system.....	7
Vent termination location requirements (for installations in Canada).....	8
Vent termination location requirements (for installations in the U.S.A.).....	8
Common Venting.....	8
For coaxial venting systems only.....	9
About These Installation Instructions.....	10
General Information	
General Rigid Pipe Installation Information.....	11
Installation steps (outline).....	11
Vent system manufacturers.....	11
Leak test (for coaxial venting systems only).....	11
Recommended venting practice.....	12
Side Wall Vent Installation (Coaxial)	
Side Wall Venting Layouts.....	13
Standard sidewall venting layout with basic coaxial vent componentry.....	13
Coaxial Vent Adaptor.....	14
Coaxial Vent Termination.....	16
Coaxial vent termination installation.....	16
Protective screen.....	16
Vent Length.....	17
Equivalent vent length calculation example.....	17
Vertical Vent Installation (Coaxial)	
Vertical Venting Layouts.....	18
Layout of vertical vent system with accessories.....	18
General installation examples.....	19
Component Installation Guide.....	20
Coaxial vent termination installation.....	20
Ceiling opening information.....	20
Vertical vent information.....	20
Vent termination location requirements.....	21
Flashing and storm collar installation.....	21
Installation of Support System.....	22
Supports.....	22
Bracing.....	22
Vent Length Requirements.....	23
Maximum vent length with increasers.....	23
Maximum vent length.....	23
Minimum vent length.....	23
Equivalent vent length calculation example.....	23

	Page
Direct Venting (Two-pipe System)	
Exhaust Vent/Air Intake Requirements.....	24
General requirements.....	24
Combustion Air Supply.....	24
General Installation Information.....	25
Installation steps (outline).....	25
Exhaust and combustion air piping material.....	25
Approved materials for two-pipe system.....	26
Vent Requirements - Stainless Steel.....	27
Component Parts of the Venting System - Stainless Steel.....	29
Exhaust vent termination options (vertical installation).....	29
Other exhaust vent termination options (horizontal installation).....	29
Vent Requirements - CPVC.....	30
Vent and Air Intake Pipe Starter Adaptors - CPVC.....	31
Requirements for UL/ULC Listed Rigid PP(s)	
Vent Pipe Material.....	32
Vent system manufacturers.....	32
Vent and Air Intake Pipe Starter Adaptors - PP(s).....	33
Side Wall Vent Termination - Stainless Steel, CPVC or PP(s).....	34
Vent Length Requirements.....	35
Flue Vent Termination Requirements.....	40
Component Parts of the PP(s) Venting System.....	41
Vertical pipe system.....	41
Horizontal pipe system.....	42
Single Pipe Venting (Room Air Dependent)	
Venting - Single Pipe (Room Air Dependent).....	43
Vent Requirements.....	43
Combustion air supply.....	43
General Installation Information.....	44
Installation steps (outline).....	45
Exhaust vent pipe material.....	45
Approved material for single pipe vent system.....	46
Support system.....	46
Flashing and storm collar installation.....	46
Additional requirements for stainless steel vent pipe material.....	47
Vent Requirements - Stainless Steel.....	47
Vent Requirements - CPVC.....	48
Requirements for UL/ULC Listed Rigid PP(s)	
Vent Pipe Material.....	49
Vent system manufacturers.....	49
Side Wall Vent Termination.....	50
Vent Length Requirements.....	51
Component Installation Guide.....	53
General single-pipe vertical venting layout.....	53
Single-pipe vent starter adaptor installation.....	54
Ceiling/Roof opening.....	54
Flashing and storm collar installation.....	54
Vent Termination Location Requirements.....	55
Vent Length Requirements.....	56
Flue Vent Length Requirements.....	57
Multiple boiler installations (vertical termination).....	57
Multiple boiler installations (horizontal termination).....	57
Installation of Support System - PP(s).....	58
Supports.....	58
Bracing.....	58

	Page
General Information	
	General Flexible Pipe Installation Information.....59
	Vent system manufacturers.....59
	Exhaust vent installation steps.....60
	Recommended venting practice.....61
	Ceiling / roof opening.....61
Direct Venting (Two-pipe System)	
	Combustion Air Supply.....62
	Venting Options (Two-Pipe System).....63
	Vent Requirements - Flexible Vent System /
	Connector Pipes.....64
	Additional requirements for UL/ULC-listed flexible vent system / connector pipe vent material.....64
	Required starter adaptors for CPVC air intake system / PP(s) flex vent system.....64
	Side Wall Air Intake Termination.....65
	Vent Length Requirements.....66
	Maximum vertical exhaust vent pipe length and vertical air intake pipe length.....66
	Maximum vertical exhaust vent pipe length and horizontal air intake pipe length.....67
	Standard long sweep elbows (for CPVC / PVC / ABS pipes air intake use only).....68
Single Pipe Venting (Room Air Dependent)	
	Combustion Air Supply.....69
	Vent Length Requirements.....70
	Maximum vertical exhaust vent pipe length.....70
Additional Information	General Component Parts of the Flex Venting System...71

Important Regulatory and Installation Requirements

For installations on the Commonwealth of Massachusetts, the following modifications to NFPA-54 chapter 10 apply:

Excerpt from 248 CMR 5-08:

- 2(a) For all side-wall horizontally vented gas fueled equipment installed in every dwelling, building or structure used in whole or in part for residential purposes, including those owned or operated by the Commonwealth and where the side-wall exhaust vent termination is less than (7) feet above finished grade in the area of the venting, including but not limited to decks and porches, the following requirements shall be satisfied:
1. **INSTALLATION OF CARBON MONOXIDE DETECTORS.** At the time of installation of the side-wall horizontal vented gas fueled equipment, the installing plumber or gas fitter shall observe that a hard wired carbon monoxide detector with an alarm and battery back-up is installed on the floor level where the gas equipment is to be installed. In addition, the installing plumber or gas fitter shall observe that a battery operated or hard wired carbon monoxide detector with an alarm is installed on each additional level of the dwelling, building or structure served by the side-wall horizontal vented gas fueled equipment. It shall be the responsibility of the property owner to secure the services of qualified licensed professional for the installation of hard-wired carbon monoxide detectors.
 - a. In the event that the side-wall horizontally vented gas fueled equipment is installed in a crawl space or an attic, the hard-wired carbon monoxide detector with alarm and battery back-up may be installed on the next adjacent floor level.
 - b. In the event that the requirements of this subdivision can not be met at the time of completion of installation, the owner shall have a period of thirty (30) days to comply with the above requirements; provided, however, that during said thirty (30) day period, a battery operated carbon monoxide detector with an alarm shall be installed.
 2. **APPROVED CARBON MONOXIDE DETECTORS.** Each carbon monoxide detector as required in accordance with the above provisions shall comply with NFPA 720 and be ANSI/UL 2034 listed and IAS certified.
 3. **SIGNAGE.** A metal or plastic identification plate shall be permanently mounted to the exterior of the building at a minimum height of eight (8) feet above grade directly in line with the exhaust vent terminal for the horizontally vented gas fueled heating appliance or equipment. The sign shall read, in print size no less than one-half (1/2) inch in size, "GAS VENT DIRECTLY BELOW. KEEP CLEAR OF ALL OBSTRUCTIONS".
 4. **INSPECTION.** The state or local gas inspector of the side-wall horizontally vented gas fueled equipment shall not approve the installation unless, upon inspection, the inspector observes carbon monoxide detectors and signage installed in accordance with the provisions of 248 CMR 5.08(2)(a) 1 through 4.
- (b) **EXEMPTIONS:** The following equipment is exempt from 248 CMR 5.08(2)(a) 1 through 4:
1. The equipment listed in Chapter 10 entitled "Equipment Not Required To Be Vented" in the most current edition of NFPA 54 as adopted by the Board; and
 2. Product Approved side-wall horizontally vented gas fueled equipment installed in a room or structure separate from the dwelling, building or structure used in whole or in part for residential purposes.

Important Regulatory and Installation Requirements *(continued)*

IMPORTANT

When replacing parts, use original Viessmann or Viessmann approved replacement parts.

For coaxial and rigid PP(s) venting system only; Venting material must be ULC S636 listed.

The venting system must be installed by a licensed professional heating contractor familiar with the operation and maintenance of heating appliances and venting. Before installing this product, ensure that the complete installation literature has been read. Failure to follow proper installation procedures as stated in these instructions, including vent pitch and proper appliance connections, may violate local, provincial/state, or national codes and cause unsafe conditions which may lead to severe property damage or personal injury.

The venting system must be installed in accordance with local building code requirements as well as national codes. For installations in Canada use CAN/CSA-B149.1 Natural Gas Installation Code or CAN/CSA-B149.2 Propane Installation Code as applicable; in the U.S. use the National Fuel Gas Code ANSI Z223.1 or NFPA Standard 54. Always use the latest edition of the applicable standard.

To ensure safe operation of the appliance, Viessmann recommends that the system be inspected once a year by a qualified service technician.

Every venting system must be planned and installed for optimum performance and safety. These Installation Instructions are designed to help you determine venting requirements and limitations with respect to installation. Please read and follow these instructions carefully.

It is the responsibility of the installer to contact local building and fire officials concerning any installation restrictions and/or inspection requirements that may apply. Permits may be required before commencement of the installation.

The vent termination for side wall air intake installations should be located on a wall that is least affected by prevailing winds. High winds may affect boiler operation and/or degrade the exterior finish of the wall. They may also cause recirculation of the appliance's own flue products. Recirculation of flue products can result in poor combustion and inlet condensation problems. If wind is a problem, steps must be taken to shield the vent termination from high winds, such as building a fence or planting shrubs. Ensure that the total equivalent vent length is not exceeded.

Operation with direct vent using coaxial vent system

IMPORTANT

Side wall vent installations must include Viessmann protective screen.

The Vitocrossal 300 CU3A boiler, flue gas adaptor is approved under CSA 4.9. ANSI Z21.13 Standard.

The venting system components are tested and listed ULC S636 or UL 1738 and are marked and labelled on each component.

DO NOT mix pipe, fittings, or joining methods from different vent system manufacturers.

DO NOT use adhesives of any kind with this venting system.

The vent length requirements stated in this manual (starting on page 34 for direct vent installations and page 62 for single pipe vent installations) must be observed.

The combustion air is supplied and the flue gas discharged via a coaxial double pipe. Combustion air is fed through the circular gap between the outer aluminum air intake pipe and the vent pipe. Flue gases are discharged via an inner pipe constructed from flame-retardant plastic (polypropylene rated for a maximum temperature of 230°F (110°C)).

Not all inspection authorities require a leak test of the vent-air intake system in conjunction with the wall-mounted gas-fired boiler during system start-up.

In cases where the leak test is not required, Viessmann recommends that the heating contractor perform a simplified leak test when starting up the system. For this purpose, it is sufficient to measure the CO₂ concentration in the combustion air of the circular gap of the coaxial vent-air intake pipe. The vent pipe is considered sufficiently leak-proof if the CO₂ concentration in the combustion air is no higher than 0.2% and the O₂ concentration no lower than 20.6%.

If higher CO₂ or lower O₂ values are measured, the flue gas system must be checked for leaks.

The coaxial venting material can be extended (without exceeding the maximum equivalent length) beyond the outside wall of the structure, provided that the coaxial venting material is installed in an enclosed, insulated and waterproof chase that is acceptable for outdoor installation. The vent termination location must comply with the instructions and codes stated in this manual.

IMPORTANT

Potential gaps between the vent-air intake and surrounding construction which may cause air, rain or flue gases to leak into the wall or the building, must be sealed with approved sealant/caulking to prevent leakage of any kind.

Because of its sealed combustion chamber, the Vitocrossal 300 CU3A gas-fired condensing boiler is suitable for operation with direct vent applications.

Important Regulatory and Installation Requirements *(continued)*

Vent termination location requirements (for installation in Canada)

The vent must be installed observing local regulations in addition to National Codes, CAN/CSA-B149.1 or 2.

A vent must NOT terminate...

1...directly above a paved sidewalk or paved driveway which is located between two single-family dwellings and serves both dwellings.

2...less than 7 ft. (2.13 m) above a paved sidewalk or a paved driveway located on public property.

3...within 6 ft. (1.83) m of a mechanical air supply inlet*1 to any building (dryer vents, non-sealed combustion furnace and hot water heater vents are considered to be mechanical air inlets).

*1 *Including heat recovery units.*

4...above a meter/regulator assembly within 3 ft. (0.9 m) horizontally of the vertical centerline of the regulator vent outlet and to a maximum vertical distance of 15 ft. (4.5 m).

5...within 3 ft. (0.9 m) of any gas service regulator vent outlet.

6...less than 1 ft. (0.3 m) above grade level or anticipated snow level (consult local building authorities or local weather office). Locate the vent termination in such a way that it cannot be blocked by snow.

7...within the following distances of a window or door which can be opened in any building, any non-mechanical air supply inlet to any building or the combustion air inlet of any other appliance:

- 1 ft. (0.3 m) for inputs up to and including 100 000 Btu/h (30 kW).
- 3 ft. (0.9 m) for input exceeding 100 000 Btu/h (30 kW).

Vent termination location requirements (for installation in the U.S.A.)

The vent must be installed observing local regulations in addition to National Codes, ANSI-Z223.1 or NFPA 54.

A vent must NOT terminate...

1...less than 7 ft. (2.13 m) above a paved sidewalk or a paved driveway located on public property.

2...above a meter/regulator assembly within 3 ft. (0.9 m) horizontally of the vertical centerline of the regulator vent outlet and to a maximum vertical distance of 15 ft. (4.5 m).
.....within 3 ft. (0.9 m) of any gas service regulator vent outlet.

3...at least 3 ft. (0.9 m) above any forced air inlet located within 10 ft. (3 m).

4...less than 1 ft. (0.3 m) above grade level or anticipated snow level (consult local building authorities or local weather office). Locate the vent termination in such a way that it cannot be blocked by snow.

5...within 1 ft. (0.3 m) of a window or door which can be opened in any building, any non-mechanical air supply inlet to any building or the combustion inlet of any other appliance.

8...underneath a veranda, porch or deck, unless:

- the veranda, porch, or deck is fully open on a minimum of two sides beneath the floor, and
- the distance between the top of the vent termination and the underside of the veranda, porch, or deck is greater than 1 ft. (0.3 m).

9...in areas where condensation may cause problems, such as above planters, patios, or adjacent to windows where flue gases may cause fogging.

10...within 3 ft. (0.9 m) to the property line (advisable, not mandatory; please check with local building authorities and municipal bylaws).

11...at a location where ice formation on the ground can present a hazard.

12...so that the flue gases are directed toward brickwork, soffits, siding, or other construction, in such a manner that may cause damage from heat or condensate from the flue gases.

13...where discharging hot flue gases may cause property damage or personal injury.

14...within 3 ft. (0.9 m) from an inside corner of outside walls.

6...in areas where condensation may cause problems, such as above planters, patios, or adjacent to windows where flue gases may cause fogging.

7...within 3 ft. (0.9 m) to the property line (advisable, not mandatory; please check with local building authorities and municipal bylaws).

8...at a location where ice formation on the ground can present a hazard.

9...so that the flue gases are directed toward brickwork, siding, or other construction, in such a manner that may cause damage from heat or condensate from the flue gases.

10...where discharging hot flue gases may cause property damage or personal injury.

11...within 3 ft. (0.9 m) from an inside corner of outside walls.

Important Regulatory and Installation Requirements *(continued)*

Clearance to combustibles

Top	Front	Rear	Left	Right	Vent pipe
0 in. (mm)	0 in. (mm)	0 in. (mm)	0 in. (mm)	0 in. (mm)	0 in. (mm)

For details refer to Vitocrossal 300 CU3A Installation Instructions (as may be applicable).

For coaxial venting systems only

The venting system may be concealed in a chase.

Minimum and maximum wall thickness through which the horizontal vent-air intake termination may be installed:

Minimum: 1 in. (25.4 mm)

Maximum: 19.6 in. (497.8 mm)

Vent-air intake system must be properly installed and sealed.

If coaxial venting system passes through an unheated space, such as an attic, it must be insulated. The insulation must have an R value sufficient to prevent freezing of the condensate. Armaflex insulation with ½ in. thickness and higher can be used.



WARNING

Failure to ensure that all flue gases have been safely vented to the outdoors can cause property damage, severe personal injury, or loss of life. Flue gases may contain deadly carbon monoxide.



CAUTION

Under certain climatic conditions some building materials may be affected by flue products expelled in close proximity to unprotected surfaces. Sealing or shielding of the exposed surfaces with a corrosion resistant material (e.g. aluminum sheeting) may be required to prevent staining or deterioration. The protective material should be attached and sealed (if necessary) to the building before attaching the vent termination. It is strongly recommended to install the vent termination on the leeward side of the building.

About These Installation Instructions

 Take note of all symbols and notations intended to draw attention to potential hazards or important product information. These include "WARNING", "CAUTION", and "IMPORTANT". See below.

 WARNING
Indicates an imminently hazardous situation which, if not avoided, could result in death, serious injury or substantial product/property damage.

► *Warnings draw your attention to the presence of potential hazards or important product information.*

 CAUTION
Indicates an imminently hazardous situation which, if not avoided, may result in minor injury or product/property damage.

► *Cautions draw your attention to the presence of potential hazards or important product information.*

IMPORTANT

► *Helpful hints for installation, operation or maintenance which pertain to the product.*



► *This symbol indicates that additional, pertinent information is to be found.*



► *This symbol indicates that other instructions must be referenced.*

General Rigid Pipe Installation Information

Installation steps (outline)

 **WARNING**

Ensure that the entire venting system is protected from physical damages. A damaged venting system may cause unsafe conditions.

 **WARNING**

The venting system is approved for indoor installations only. Do not install the venting system outdoors.

IMPORTANT

Proximity to damp and salty marine environments directly influences the service life of the boiler’s exposed metallic surfaces, such as the casing and fan housing. In such areas, higher concentration levels of chlorides from sea spray, coupled with relative humidity, can lead to degradation of the exposed metallic surfaces mentioned above. Therefore, it is imperative that boilers installed in such environments not be installed using direct vent systems which draw outdoor air for combustion. Such boilers must be installed using room air dependent vent systems; i.e. using room air for combustion. The indoor air will have a much lower relative humidity and, hence, the corrosion will be minimized.

- Route vent pipe as directly as possible and with as few bends as possible to the boiler.
- Check proper location of gaskets in rigid PP(s) pipe collars. (Only use supplied parts with the polypropylene venting system.)
Apply water to lubricate the joint ends of the vent pipe collar and if used, the air intake pipe collar.
- Slide pipes into each other with a gentle twisting motion.
- Condensate must drain from the flue pipe to the boiler. Ensure a suitable gradient of at least 3° [approx. 2 in. per 3.3 ft. (50 mm per 1 m)].
- Use a hacksaw or sheet metal snips (for stainless steel) to cut pipes to length (if necessary). Use a file to smooth rough edges. Pipe must be round and not bent into an oval shape.

IMPORTANT

When cutting pipes to length, debur and clean pipes.

Vent system manufacturers

The following Coaxial and PP(s) vent system manufacturers may be contacted for assistance in designing the appropriate venting system for Vitocrossal 300 CU3A boilers.

M&G / Duravent www.duravent.com	Centrotherm InnoFlue www.centrotherm.us.com
*PolyFlue - Selkirk www.polyflue.com	ECCO Manufacturing www.eccomfg.com
Z-FLEX US Inc. NovaFlex Group www.novaflex.com	

* requires double pipe system with coaxial termination only.

For Vitocrossal 300 CU3A-45/57 (with boiler flue termination 110 mm) the vent manufacturers M&G and PolyFlue requires a transition adaptor.

Leak test (for coaxial venting systems only)

Viessmann recommends that the heating contractor perform a simplified leak test during boiler start-up. For this purpose it is sufficient to measure the CO₂ concentration of the combustion air in the annular gap of the air intake pipe.

The vent pipe is considered sufficiently leak-proof if a CO₂ concentration in the combustion air no higher than 0.2% or an O₂ concentration no lower than 20.6% is measured relative to a starting O₂ concentration of 20.9%.

If higher CO₂ values or lower O₂ values are measured, inspect the venting system thoroughly.

Continuous short cycling of the boiler can indicate a leaking venting system.

Note: The boiler’s flue gas termination has an integrated port for flue gas measurement.

General Installation Information *(continued)*

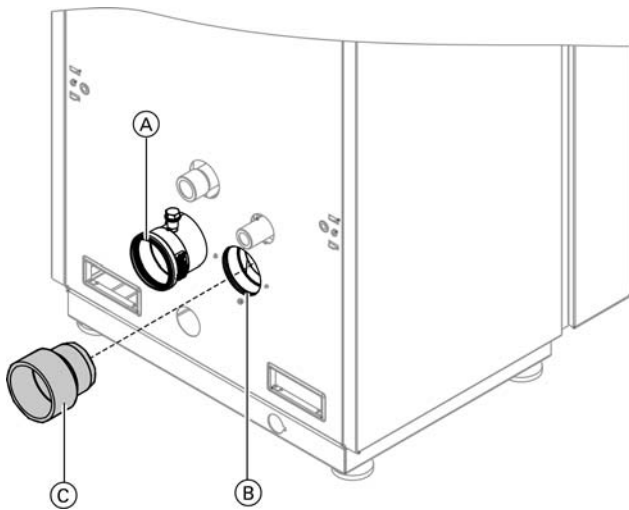

Legend

- Ⓐ Boiler flue termination
CU3A 26-35 80 mm
CU3A 45-57 110 mm
- Ⓑ Combustion air intake 80 mm
- Ⓒ Combustion air 80 mm to 3 in. CPVC adaptor is supplied with the boiler installation fittings
(May be used with CPVC/ABS air intake pipe system)

Recommended venting practice

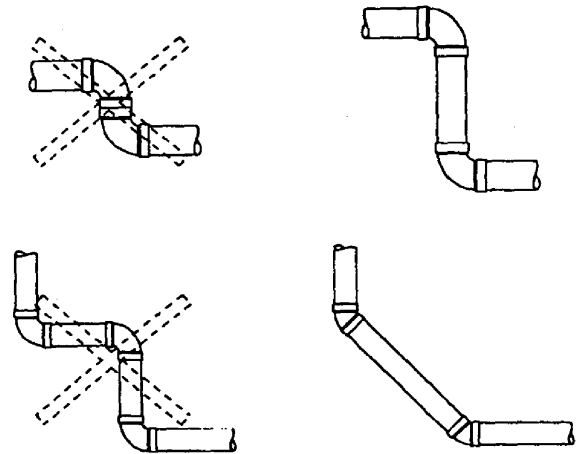

When installing a venting system the following recommended venting practices apply:

- Keep length and number of 90° elbows to a minimum.
- Try not to use back-to-back 90° elbows.
- Use 45° elbows where possible to minimize the number of 90° elbows in case redirection of flue gas is required.
- The special vent system shall not be routed into, through, or within any other vent such as an existing masonry or factory-built chimney.

Exception:

A masonry chimney flue may be used to route the venting system only if no other appliance is vented in the same flue.

IMPORTANT

Route the flue gas connection to be free of load and torque stresses. We recommend fitting an on-site support immediately downstream of the boiler flue connection.

! WARNING

The Vitocrossal 300 CU3A boiler cannot be common vented with any other appliances including additional Vitocrossal 300 CU3A boilers.

Side Wall Venting Layouts

Standard side wall venting layout with basic coaxial vent componentry

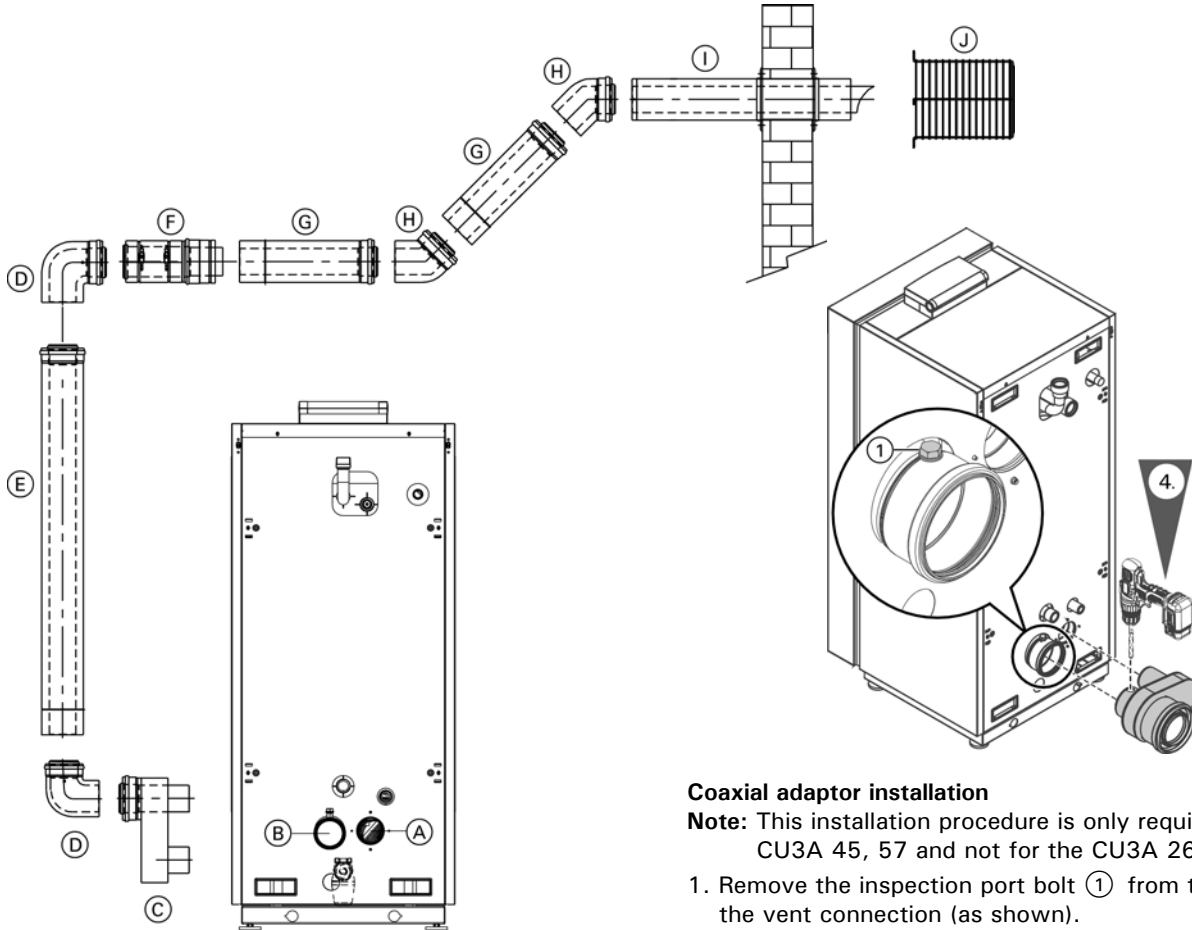

Legend

- (A) Combustion air intake
- (B) Boiler flue termination
- (C) Coaxial adaptor (field supplied)
- (D) 90° elbow
- (E) Straight pipe (long)
- (F) Telescopic extension
- (G) Straight pipe (short)
- (H) 45° elbow
- (I) Vent termination
- (J) Protective screen (Viessmann)

Note: Depending on the selected vent manufacturer, a service clearance of 36 in. may be required. Consult the vent manufacturer if using two-pipe to coaxial adaptor directly at the back of the boiler.

IMPORTANT

Total length of vent termination pipe may be shortened, if required. Follow manufacturer's instructions.

WARNING
Protective screen **MUST** be installed.

Coaxial adaptor installation

Note: This installation procedure is only required for the CU3A 45, 57 and not for the CU3A 26, 35.

1. Remove the inspection port bolt (1) from the top of the vent connection (as shown).
2. Fully insert the coaxial adaptor into the boiler.
3. Mark the center of the inspection port on the adaptor.
4. Remove the coaxial adaptor from the boiler and drill a 5/8 in. hole where marked.
5. Deburr the edges of the drilled hole.
6. Fully install the coaxial adaptor into the boiler and align the inspection port hole to the coaxial adaptor hole.
7. Reinstall the inspection port bolt (1) and tighten bolt to seal.

The Vitocrossal 300 CU3A requires a coaxial venting adaptor. This adaptor must be ordered separately through the vent manufacturer.

Coaxial venting by manufacturers		
Fully coaxial		
	CU3A 26, 35	CU3A 45, 57
Z-FLEX	80/125	110/160
Centrotherm	80/125	110/160
ECCO	80/125	110/160
M&G	80/125	100/150
Coaxial termination (only)		
	CU3A 26, 35	CU3A 45, 57
PolyFlue*	80/125 (vert.)	100/150 (horiz.)

* refer to two-pipe venting section page 39.

Coaxial Vent Adaptor

Centrotherm Coaxial Adaptor for CU3A 26, 35
(Centrotherm PN ICTCV0335)

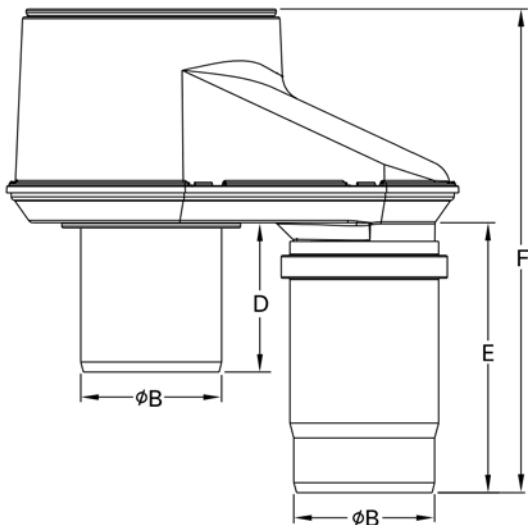
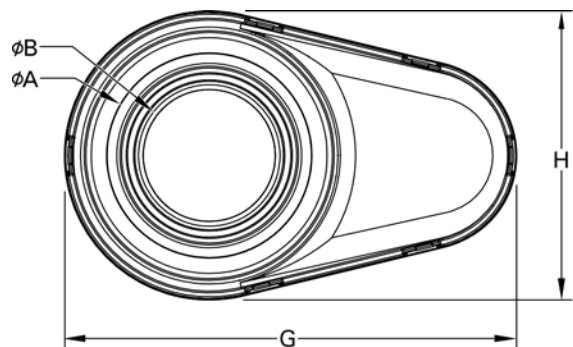

Centrotherm Coaxial Adaptor for CU3A 45, 57
(Centrotherm PN ICTCV30446)

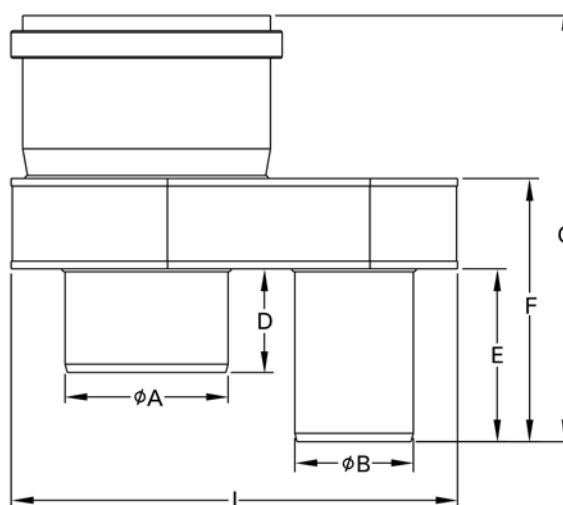
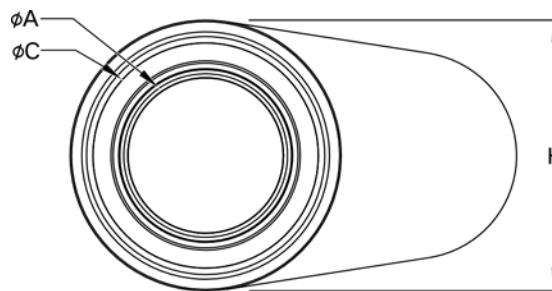

Centrotherm Coaxial Adaptor

CU3A model #	26, 35	45, 57
ØA (nominal)	125	110
ØB (nominal)	80	80
ØC (nominal)	N/A	150
D	85	70
E	153	117
F	275	178
G	257	288
H	164	183
I	N/A	301

Coaxial Vent Adaptor *(continued)*

M&G DuraVent Coaxial Adaptor for CU3A 26, 35
(M&G DuraVent PN 810013138)

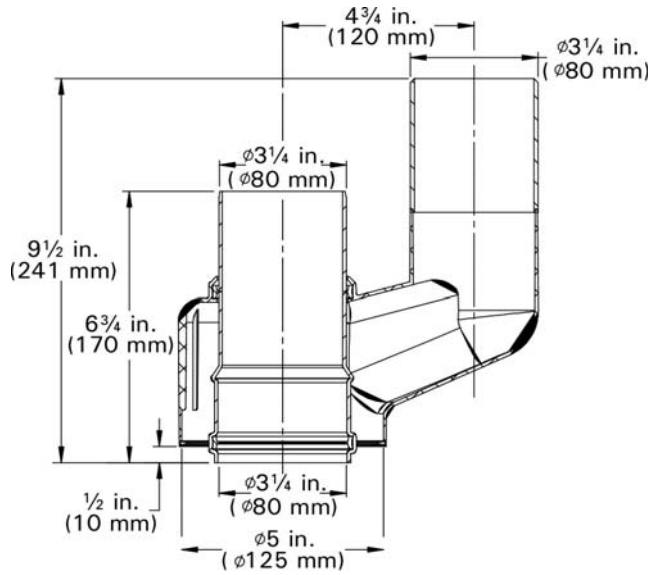

M&G DuraVent Coaxial Adaptor for CU3A 45, 57
(M&G DuraVent PN 810013139)

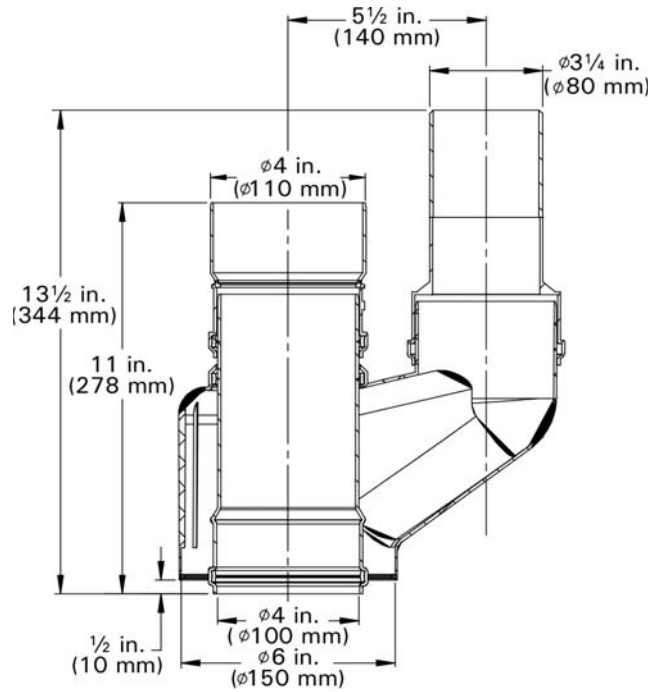

Coaxial Vent Termination

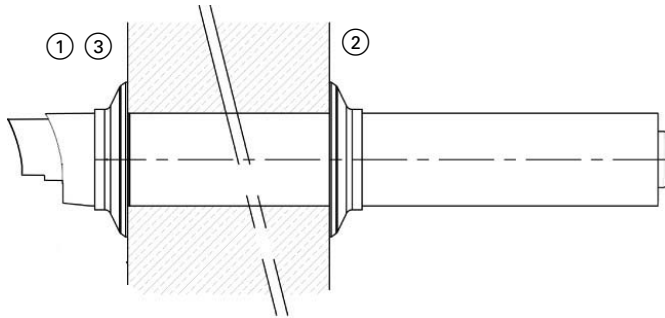

Legend

- ① Vent termination
- ② Wall flashing (inside)
- ③ Wall flashing (outside)

Wall opening information

Vent system	Opening Ø
80/125	5¼ in. (133 mm)
100/150	6⅝ in. (160 mm)
110/160	6 ¹¹ / ₁₆ in (170 mm)

Note: Termination may not be exactly as shown, refer to the vent manufacturers specific component specifications.



Refer to the vent manufacturers Installation Instructions.

IMPORTANT

Potential gaps between the vent-air intake and the surrounding construction which may cause air, rain or flue gases to leak into the wall or the building, must be sealed with approved outdoor sealant/caulking to prevent leakage of any kind.

IMPORTANT

If required the vent termination may be shortened, refer to the manufacturers instructions.

Side wall vent termination installation

1. Provide side wall opening (see table above) to install vent termination.
2. Slide vent termination ① with wall flashing ③ into opening (drain openings must be located on the outside of the wall, pointing downward).
3. Attach wall flashing ② to inside of wall using the screws and plugs provided.
4. Attach wall flashing ③ to outside of wall.

Protective screen

1. Secure protective screen (A) into place, using the four stainless steel screws and anchors.

IMPORTANT

The protective screen **MUST** be installed.

2. Connect vent termination from inside and ensure the vent termination has a min. 3° downward slope toward the boiler.

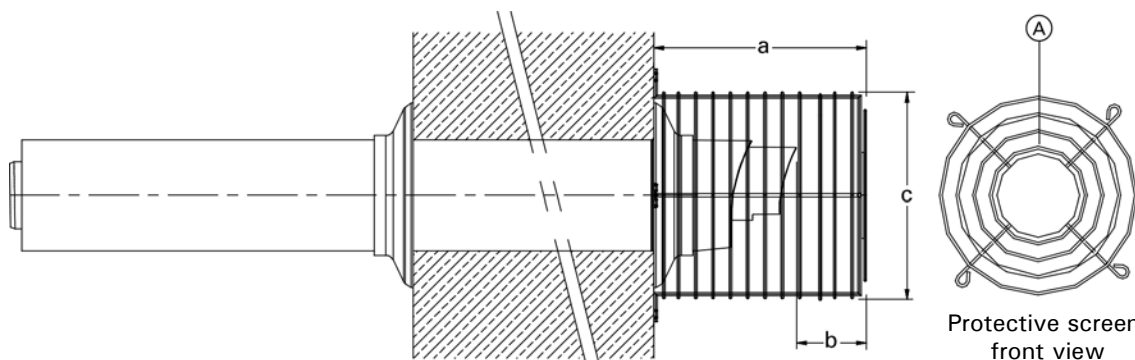

Protective screen, side view for vent system (all sizes).

Dimensions

a	b	c
12 in. (305 mm)	must be at least 4 in.	9.5 in. (241 mm)

Venting Length

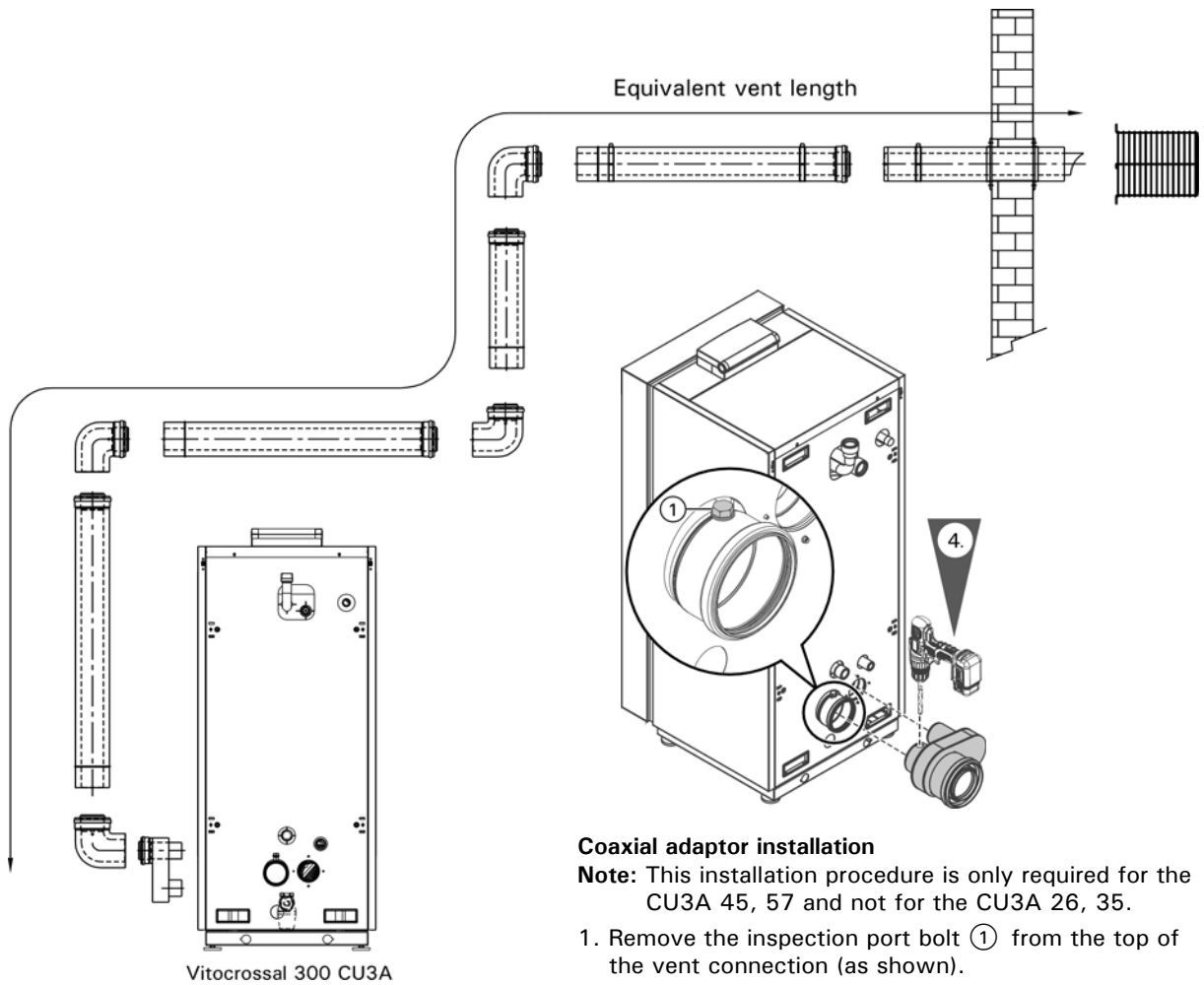

Vitocrossal 300 CU3A

Equivalent vent length calculation example

2 x 87° elbow.....	3.2 ft. (1 m)
2 x vent pipe (1 m).....	6.6 ft. (2 m)
1 x vent pipe (0.5 m).....	1.6 ft. (0.5 m)
1 x vent termination.....	2.4 ft. (0.73 m)
Total equivalent length.....	13.8 ft. (4.23 m)

IMPORTANT

First elbow is excluded from in equivalent vent calculation. Always include vent termination length in calculations.

Note: Depending on the selected vent manufacturer, a service clearance of 36 in. may be required. Consult the vent manufacturer if using two-pipe to coaxial adaptor directly at the back of the boiler.

Coaxial adaptor installation

Note: This installation procedure is only required for the CU3A 45, 57 and not for the CU3A 26, 35.

1. Remove the inspection port bolt ① from the top of the vent connection (as shown).
2. Fully insert the coaxial adaptor into the boiler.
3. Mark the center of the inspection port on the adaptor.
4. Remove the coaxial adaptor from the boiler and drill a 5/8 in. hole where marked.
5. Deburr the edges of the drilled hole.
6. Fully install the coaxial adaptor into the boiler and align the inspection port hole to the coaxial adaptor hole.
7. Reinstall the inspection port bolt ① and tighten bolt to seal.

Boiler model	Vent diameter	
	80/125	100/150 or 110/160
CU3A 26, 35	98 ft. (30 m)	108 ft. (33 m)
CU3A 45, 57	--	98 ft. (30 m)

- Do not exceed the maximum vent length.
- First 87° elbow on boiler is not included in equivalent vent length calculation.

Type of fitting	Equivalent length
87° elbow/ 87° inspection tee	1.6 ft. (0.5 m)
45° elbow	1 ft. (0.3 m)

A 10% boiler input reduction @ 30 m for all sizes and all configurations.

Vertical Venting Layouts

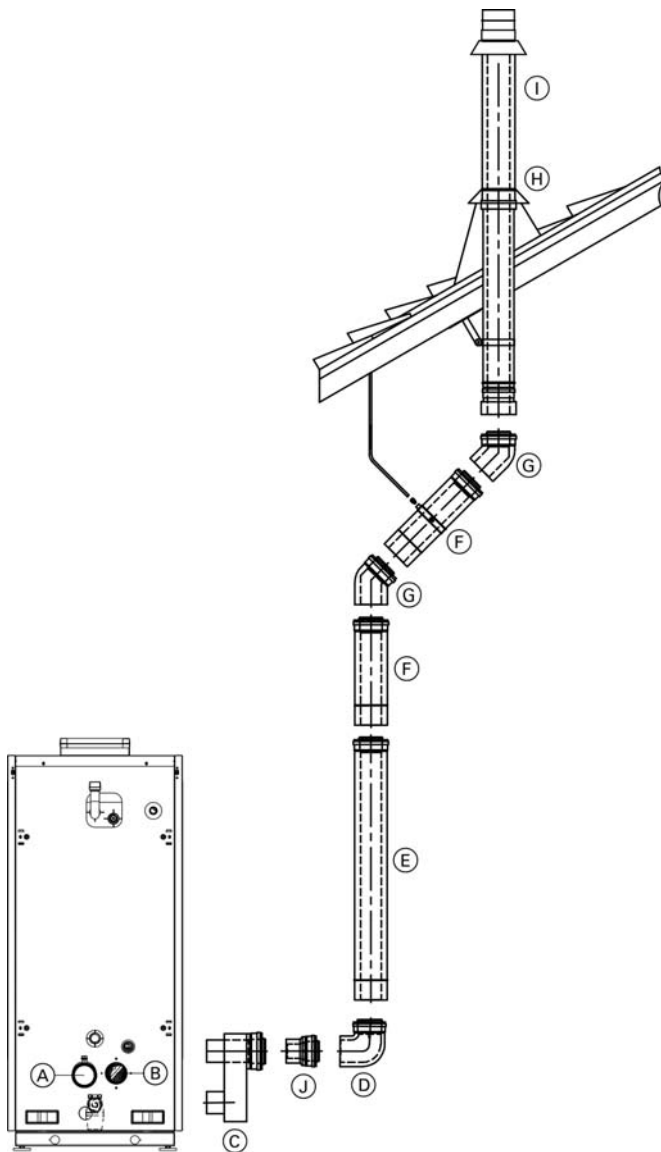

Legend

- (A) Combustion air
- (B) Boiler flue gas termination
- (C) Coaxial adaptor (field supplied)
- (D) 90° elbow
- (E) Straight pipe (long)
- (F) Straight pipe (short)
- (G) 45° elbow
- (H) Roof flashing and storm collar
- (I) Roof coaxial termination
- (J) Increaser (if required)

Note: Depending on the selected vent manufacturer, a service clearance of 36 in. may be required. Consult the vent manufacturer if using two-pipe to coaxial adaptor directly at the back of the boiler.

Layout of Vertical Vent systems with accessories

Select from the vertical vent components below as required. Do not exceed maximum equivalent vent length, see page 17).

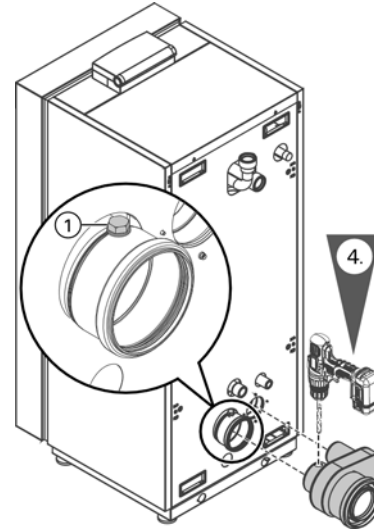

Coaxial adaptor installation

Note: This installation procedure is only required for the CU3A 45, 57 and not for the CU3A 26, 35.

1. Remove the inspection port bolt ① from the top of the vent connection (as shown).
2. Fully insert the coaxial adaptor into the boiler.
3. Mark the center of the inspection port on the adaptor.
4. Remove the coaxial adaptor from the boiler and drill a 5/8 in. hole where marked.
5. Deburr the edges of the drilled hole.
6. Fully install the coaxial adaptor into the boiler and align the inspection port hole to the coaxial adaptor hole.
7. Reinstall the inspection port bolt ① and tighten bolt to seal.

General vertical venting layout for vent systems, Roof coaxial termination ①.

Use other anchoring/support system components as required.

IMPORTANT

Ensure that the venting system is properly supported; the Vitocrossal 300 CU3A boilers are not designed to support the weight of the venting system.

IMPORTANT

Vitocrossal 300 CU3A requires an adaptor to convert to a coaxial system. Consult the vent manufacturer.

Vertical Venting Layouts *(continued)*

General installation examples

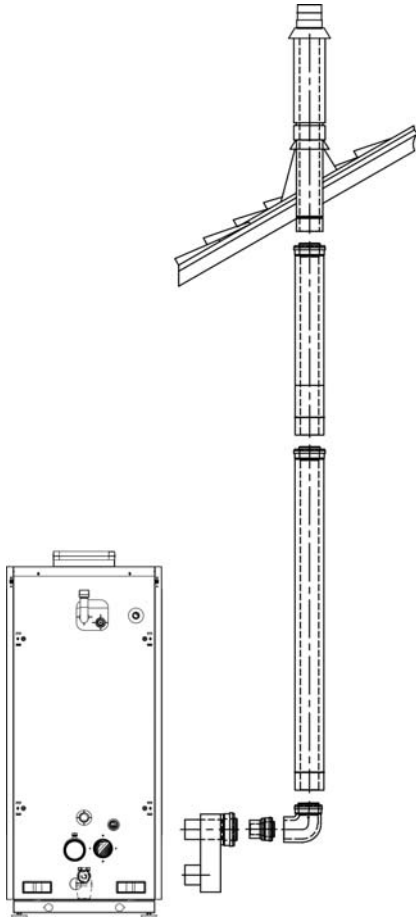

Sloped roof installation

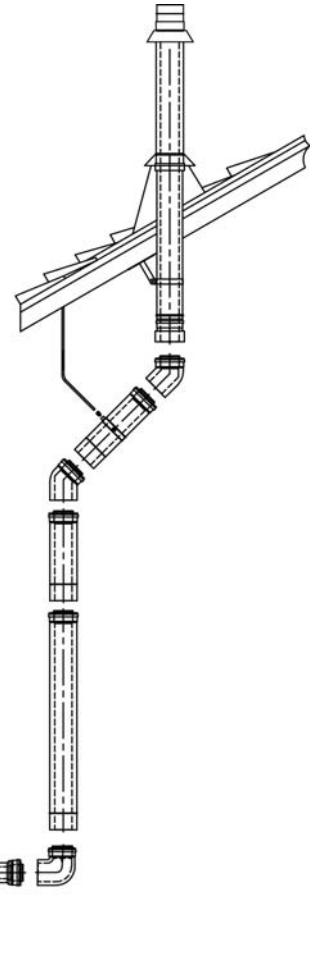

Sloped roof installation with offset

IMPORTANT

Ensure that the venting system is properly supported; the Vitocrossal 300 CU3A boilers are not designed to support the weight of the venting system.

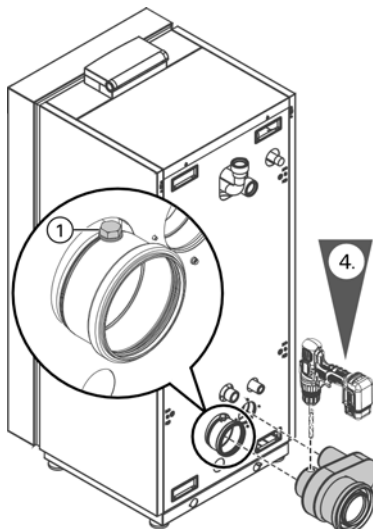

Note: Depending on the selected vent manufacturer, a service clearance of 36 in. may be required. Consult the vent manufacturer if using two-pipe to coaxial adaptor directly at the back of the boiler.

Coaxial adaptor installation

Note: This installation procedure is only required for the CU3A 45, 57 and not for the CU3A 26, 35.

1. Remove the inspection port bolt ① from the top of the vent connection (as shown).
2. Fully insert the coaxial adaptor into the boiler.
3. Mark the center of the inspection port on the adaptor.
4. Remove the coaxial adaptor from the boiler and drill a 5/8 in. hole where marked.
5. Deburr the edges of the drilled hole.
6. Fully install the coaxial adaptor into the boiler and align the inspection port hole to the coaxial adaptor hole.
7. Reinstall the inspection port bolt ① and tighten bolt to seal.

Coaxial vent termination installation

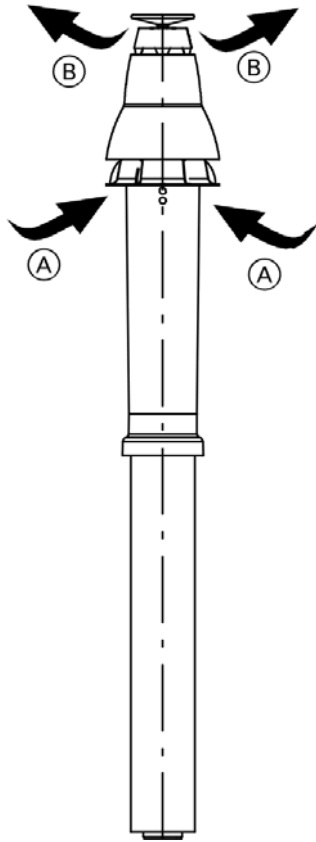

Legend

- Ⓐ Combustion air intake
- Ⓑ Flue gas outlet

Ceiling opening information

Vent system	Opening Ø
80/125 M&G, InnoFlue, PolyFlue, Z-Flex, ECCO MFG	5¼ in. (133 mm)
100/150 M&G, PolyFlue	6⅜ in. (160 mm)
110/160 InnoFlue, Z-Flex, Centratherm, ECCO MFG	6 ¹¹ / ₁₆ in. (170 mm)

Vertical vent termination installation

1. Install the vent termination for sloped or flat roof collars and flashings in accordance with the manufacturer's instructions.
2. The vent termination should be placed from above on the sloped or flat roof collar.

Component Installation Guide *(continued)*

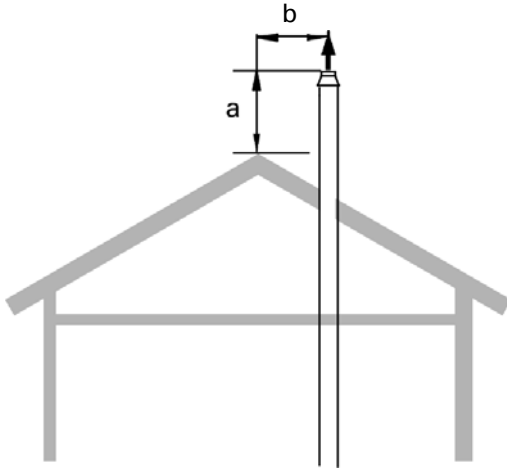

- For sloped roof applications with distance b less than 18 in. (450 mm)
 - a minimum 18 in. (450 mm)
 - b < 18 in. (450 mm)

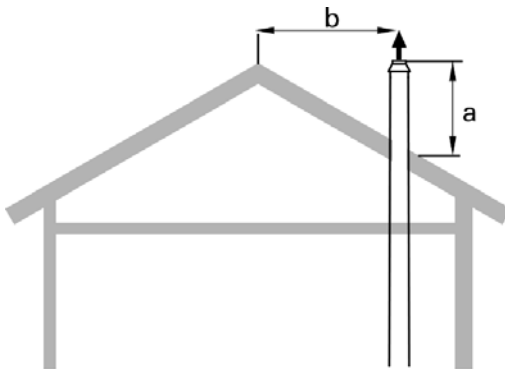

- For sloped roof applications with distance b greater than 18 in. (450 mm)
- For flat roof applications

- a minimum 18 in. (450 mm)
- b > 18 in. (450 mm)

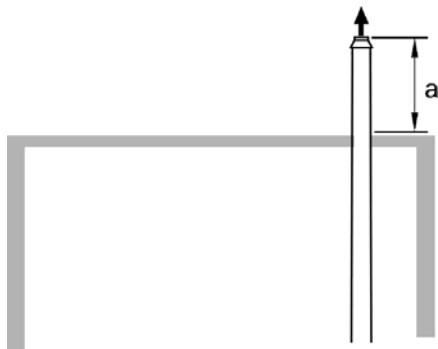

Vent termination location requirements

The vent must be installed observing local regulations in addition to National Codes, CAN/CSA-B149.1 or 2 (for installations in Canada) or ANSI-Z223.1 or NFPA 54 (for installations in the U.S.A.).

The distance between two adjacent vertical vent terminations for all boiler sizes is 1 ft. (0.3 m) (center to center).

! WARNING

Vent termination must be at least 12 in. (300 mm) above the anticipated snow level (consult your local building authorities or local weather office). Locate vent termination in such a way that it cannot be blocked by snow.

A vent used in a special venting system with positive vent pressure and passing through a roof shall extend at least 18 in. (450 mm) above the highest point where it passes through the roof and any other obstruction within a horizontal distance of 18 in. (450 mm).

Flashing and storm collar installation

Flashings and storm collars are field supplied. Flashings and storm collars suitable for Type B vent materials (or better) may be used. To obtain flashings and storm collars, please contact your local vent material supplier. Follow the installation instructions supplied by the manufacturer.

Installation of Support System

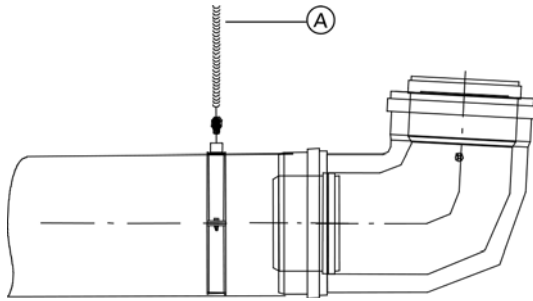

The venting system must be securely supported by an anchoring system (A) suitable for the weight and design of the materials employed.

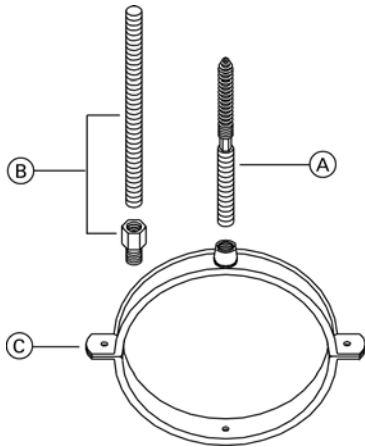

If a longer anchoring system is required use all-threaded rods (B) (field supplied).

The venting system must be securely supported by a support system suitable for the weight and design of the materials employed.

Contact your vent material supplier for more information specific to your installation.

Supports

Supports are used to transfer the weight of an installation to the building structure. There are different types of supports and their capacity varies with each type and diameter.

The following support types are available at your local vent material supplier...

- anchor plate
- wall support
- roof support
- floor support
- suspension band (hanger).

In addition to the support types listed above Viessmann offers mounting clips which can be used in conjunction with the above support types to support the weight of the venting system. Please contact Viessmann to order.

Vertical vent systems with horizontal sections must have the joints in these sections secured with the supplied sheet metal screws (A) to prevent the system from sagging.

The 4 in. (101.6 mm) screws (D) supplied with the mounting clip provide wall or ceiling support for a ...

- minimum distance of 2 in. (50.8 mm)
- maximum distance of 3¼ in. (82.5 mm).

If a longer support system is required use a brass adaptor M8 x 5/16 in. (field supplied) with 5/16 in. all threaded rods (B) (field supplied).

Bracing

Contact your local vent material supplier for more information specific to your installation.

Braces are required to stabilize an installation. There are different types and their use and spacing vary.

The following types of braces are available at your local vent material supplier...

- wall band
- wall band extension
- guy wire band
- roof brace.

IMPORTANT

Ensure that the venting system is properly supported; the Vitocrossal 300 CU3A boiler is not designed to support the weight of the venting system.

Vent Length Requirements

Maximum vent length with increasers

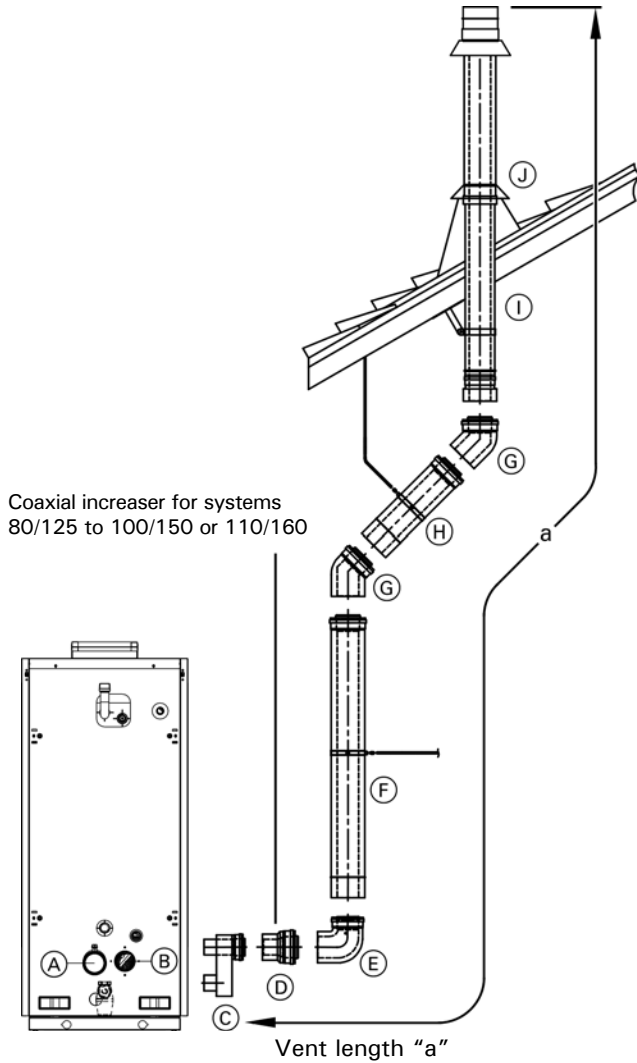

Legend

- (A) Combustion air
- (B) Boiler flue gas termination
- (C) Coaxial adaptor (Vent manufacturer)
- (D) Increaser
- (E) 90° elbow
- (F) Straight pipe (long)
- (G) 45° elbow
- (H) Straight pipe (short)
- (I) Vent termination
- (J) Roof flashing and storm collar

Note: Depending on the selected vent manufacturer, a service clearance of 36 in. may be required. Consult the vent manufacturer if using two-pipe to coaxial adaptor directly at the back of the boiler.

Maximum vent length

Model No.	CU3A 26, 35	
System vent size	80/125	100/150* ¹ 110/160
Max. vent length "a"	ft. (m)	98 (30) 110 (33)

*¹ If used with increasers 100/150, 110/160

Model No.	CU3A 45, 57	
System vent size	80/125	100/150 110/160
Max. vent length "a"	ft. (m)	-- 98 (30)

Minimum vent length

The minimum equivalent vertical vent length for all models is 4 ft. (1.2 m) (= length of vent termination).

IMPORTANT

Always include vent termination length in calculations.

Type of fitting	Equivalent length
87° elbow/ 87° inspection tee	1.6 ft. (0.5 m)
45° elbow	1 ft. (0.3 m)

Note: First elbow not included in equivalent vent calculation.

Equivalent vent length calculation example:

2 x 87° elbow.....	3.2 ft. (1 m)
2 x 45° elbow.....	2 ft. (0.6 m)
3 x vent pipe (short).....	4.8 ft. (1.5 m)
1 x vent pipe (long).....	3.3 ft. (1 m)
1 x telescopic extension (average length)...	1.0 ft. (0.31 m)
1 x vent termination.....	4.2 ft. (1.28 m)
Total equivalent length.....	18.6 ft. (5.67 m)

Exhaust Vent/Air Intake Requirements

General requirements

The Vitocrossal 300 CU3A boilers must be located in such a way that the vent length is as short as possible and that the vent can be routed as directly (and with as few bends) as possible.

The minimum equivalent vent length is 3.3 ft. (1 m). See tables on pages 35, 36 and 37 for maximum and minimum vent lengths.

All products of combustion must be safely vented to the outdoors. All Vitocrossal 300 CU3A boilers vent under positive pressure and are Category IV boilers.

! WARNING
Failure to ensure that all flue gases have been safely vented to the outdoors can cause property damage, severe personal injury, or loss of life. Flue gases may contain deadly carbon monoxide.

Viessmann recommends that the entire vent system be checked by a licensed professional heating contractor at least once each year following initial installation.

The stainless steel special venting system is completely sealed when fully assembled. Locking bands or other method of joining are used to reinforce the joints between pipe and fittings.

! WARNING
Different manufacturers offer a number of different joint systems and adhesives. Do not mix pipes, fittings and/or joining methods from different manufacturers. Failure to comply could result in leakage, potentially causing personal injury or death.

Do not install vent pipe in a way that flue gases flow downwards. The direction of flue gas flow must be vertically upwards or horizontal with an upward slope. Ensure there is no flue gas leakage into the area in which the boiler is installed.

Check joints for leaks with the gas supply turned off and the fan running. Use a soapy solution to check for vent leaks. Condensate must drain from the flue pipe to the boiler. Ensure a suitable gradient of at least 3° [approx. 2 in. per 3.3 ft. (50 mm per 1 m)].

No condensate trap is required in the vent pipe system.

If exhaust vent pipe system passes through an unheated space, such as an attic, it must be insulated. The insulation must have an R value sufficient to prevent freezing of the condensate. Armaflex insulation with ½ in. thickness and higher can be used.

The remaining space surrounding a chimney liner, gas vent, or special gas vent or plastic piping installed within a masonry, metal or factory-built flue shall not be used to supply combustion air to the boiler. A separate combustion air intake pipe routed back to the boiler can be used in the remaining space if required, the boiler venting system is approved for zero clearance, and can be run directly beside the combustion air intake pipe.

Combustion Air Supply

The Vitocrossal boiler is suitable for sidewall, as well as vertical venting. The Vitocrossal 300 CU3A boilers are approved for both direct vent (sealed combustion), as well as direct exhaust (non-sealed combustion) operation in both horizontal and vertical arrangements. For non-sealed combustion vent systems (i.e. room-air dependent), see appropriate section under "Single Pipe Venting" starting on page 43 in this manual.

The boiler must be connected to a direct vent system in which all air for combustion is taken from the outside atmosphere and all combustion products are discharged safely to the outdoors. The boiler must be vented and supplied with combustion air and exhaust vent as described in this section. Ensure the vent and combustion air supply comply with these instructions.

! CAUTION
Do not locate boiler in areas where high dust levels or high humidity levels are present.

! CAUTION *
Do not install boiler during construction involving drywall or heavy dust of any kind. Dust can accumulate in the burners and cause sooting. Install boiler after all heavy dust construction is completed.

* Typically when the boiler is used as a temporary heat source during the building construction phase.

Inspect all finished exhaust vent/air intake piping to ensure:

- Vent/air intake pipe and fittings are of approved material.
- Acceptable size, length and number of elbows on combined vent/air intake system.
- Installation is in accordance with prevailing provisions of local codes.
- Installation complies with the requirements of these instructions, as well as the exhaust vent/air intake supplier's instructions.

The exhaust vent and combustion air intake system and terminations may be installed in one of the following type terminations (2-pipe system):

1. Horizontal air intake and exhaust vent pipes.
2. Vertical air intake and exhaust vent pipes.
3. Horizontal air intake pipe and vertical exhaust vent pipe.

! CAUTION
If the boiler has been exposed to high dust levels, all burners and the heat exchanger must be cleaned prior to use.

! CAUTION
If above criteria are not properly observed and boiler damage results, any warranty on the complete boiler and related components will be null and void.

General Installation Information

Installation steps (outline)

Exhaust and combustion air piping material

Use only the materials listed on page 26 entitled "Approved materials for two-pipe system" on page 37 for exhaust, combustion air intake pipe and fittings.

- Cut the pipe end square and remove all burrs and debris from joints and fittings.
- If using CPVC special vent material for exhaust vent pipe and ABS / PVC / CPVC for combustion air intake pipe, all joints must be properly cleaned, primed and cemented. Use only cement and primer approved for the use with the pipe material. See table entitled "Approved materials for two-pipe system" on page 26 for approved solvent cement material.

CAUTION

For solvent cement and primer:

- Use only in well ventilated areas
- Do not use near flame or open fire
- Use only the solvent cement and primer appropriate for the venting material being used
- Solvent cements for plastic pipe are flammable liquids and must be kept away from all sources of ignition

- For rigid PP(s) venting system only; Venting material must be ULC S636 or UL 1738 listed, (see page 27 for listed manufacturers).
- No low point is allowed in the exhaust vent pipe system, unless a proper drain pipe is used to allow condensate to drain.

WARNING

Ensure that the entire venting system is protected from physical damages. A damaged venting system may cause unsafe conditions.

WARNING

The venting system is approved for indoor installations only. Do not install the venting system outdoors.

- Route vent pipe as directly as possible and with as few bends as possible to the boiler.
- Condensate must drain from the flue pipe to the boiler. Ensure a suitable gradient of at least 3° [approx. 2 in. per 3.3 ft. (50 mm per 1 m)].
- Use a hacksaw or sheet metal snips (for stainless steel) to cut pipes to length (if necessary). Use a file to smooth rough edges. Pipe must be round and not bent into an oval shape.
- Check proper location of gaskets in rigid PP(s) pipe collars. (Only use supplied parts with the polypropylene venting system.)
Apply water to lubricate the joint ends of the vent pipe collar and if used, the air intake pipe collar.
- Slide pipes into each other with a gentle twisting motion.

IMPORTANT

When cutting pipes to length, debur and clean pipes. In conjunction with these instructions, follow the installation instructions supplied by the special venting manufacturer.

- All piping must be fully supported. Use pipe hangers at intervals specified by manufacturers to prevent sagging of the pipe.
- The exhaust vent/air intake pipe and fittings must be securely supported by a support system suitable for the weight and design of the material employed. Contact your local vent material supplier for more information specific to your installation(s).

IMPORTANT

Ensure that the exhaust vent/air intake pipes are properly supported. The Vitocrossal 300 CU3A boiler is not designed to support the weight of the exhaust vent/air intake pipe system.

- Field supplied increaser fittings (transition) should always be inserted in vertical sections of pipe to prevent accumulation of condensate in the vent pipe.
- The total equivalent length specified for a two-pipe system is the total of the combined length of the exhaust vent/air intake pipe system. Do not exceed these maximum lengths.

General Installation Information *(continued)*

Approved materials for two-pipe system

Part	Material	Certified to Standards	Applicability
Exhaust pipe and fitting	Stainless steel	UL1738 "Venting systems for gas-burning appliances, Categories II, III, IV"	U.S.A./Canada
		ULC S636 "Standard for Type BH gas venting systems"	
	CPVC	UL1738 "Venting systems for gas-burning appliances, Categories II, III, IV"	
		ULC S636 "Standard for Type BH gas venting systems" Class IIB 90°C	
	Polypropylene PP(s)	UL1738 "Venting systems for gas-burning appliances, Categories II, III, IV"	
		ULC S636 "Standard for Type BH gas venting systems" Class IIC 110°C	
Combustion air pipe and fitting	Stainless steel	n.a.	
	PVC-DWV Schedule 40	ANSI/ASTM D2661 CSA B181.1 ULC S102.2 ANSI/ASTM D2665, D1785 CSA B137.3, B181.2 ANSI/ASTM F441	
		ANSI/ASTM D2661 CSA B181.1 ULC S102.2 ANSI/ASTM D2665, D1785 CSA B137.3, B181.2 ANSI/ASTM F441	
	ABS-DWV Schedule 40	ANSI/ASTM D2661 CSA B181.1 ULC S102.2 ANSI/ASTM D2665, D1785 CSA B137.3, B181.2 ANSI/ASTM F441	
		UL1738 "Venting systems for gas-burning appliances, Categories II, III, IV"	
	Polypropylene PP(s)	ULC S636 "Standard for Type BH gas venting systems" Class IIC 110°C	
Pipe cement, primer (for combustion air intake pipe)	PVC	ANSI/ASTM D2564 CSA B137.3	
	CPVC	ANSI/ASTM F493 CSA B137.6	
	ABS	ANSI/ASTM D2235 CSA B181.1/B182.1	
Pipe cement, primer (for exhaust pipe and fitting)	CPVC	ULC S636 "Standard for Type BH gas venting systems" Class IIB 90°C	

Note: Always use the latest edition of the applicable standard.

CAUTION
Do not use cellular (foam) core pipe material to vent this Vitocrossal 300 CU3A boiler.

CAUTION
Do not use PVC material in exhaust system.

CAUTION
On the job site, ensure that non-listed combustion air pipe materials are not inadvertently used instead of listed vent pipe material.

Vent Requirements - Stainless Steel

Additional requirements for stainless steel vent pipe material

Use special stainless steel venting system (UL/ULC listed for category IV) for horizontal or vertical venting of the Vitocrossal 300 CU3A boilers.

Contact one of the suppliers (see listing on right) to order.

Prior to installation, check that the correct single-pipe vent parts were ordered and supplied.

For special parallel/starter adaptor and bird screen models required for your installation. In case of discrepancies, contact original parts supplier.

Exhaust vent/air intake connection to boiler

The vent connection to the Vitocrossal 300 CU3A boiler must be made with the starter stainless steel adaptor (supplied by others and/or parallel adaptor). The starter adaptors are intended for a slip fit and slide into the parallel adaptor with a gentle twisting motion.

Combustion air intake pipe:

If the venting system will use CPVC, ABS or PVC plastic pipe for combustion air intake, a CPVC starter adaptor is supplied with the boiler installation fittings for use on air intake connection to parallel adaptor must be ordered from Viessmann.

The bird screen for the air intake termination elbow must also be ordered from Viessmann.

Note: The Vitocrossal 300 CU3A boiler has passed the zero inches vent clearance to combustibles testing requirements dictated by the Harmonized Standard ANSI Z21.13. CSA 4.9 and therefore is listed for zero clearance to combustibles when vented with a single pipe special venting system. The zero inches vent clearance to combustibles for the Vitocrossal 300 CU3A boiler supersedes the clearance to combustibles listing that appears on the special venting system marking.

Vent system manufacturers

PolyFlue - Selkirk www.polyflue.com	ICC - Industrial Chimney Co. www.icc-rsf.com
ProTech Systems, Inc. www.protechinfo.com	Novaflex www.novaflex.com
Security Chimneys International Ltd. www.securitychimneys.com	

WARNING

The use of vent material other than listed UL/ULC stainless steel, positive pressure vent pipe and fittings can cause property damage, severe personal injury and/or loss of life.

Vent Requirements - Stainless Steel *(continued)*

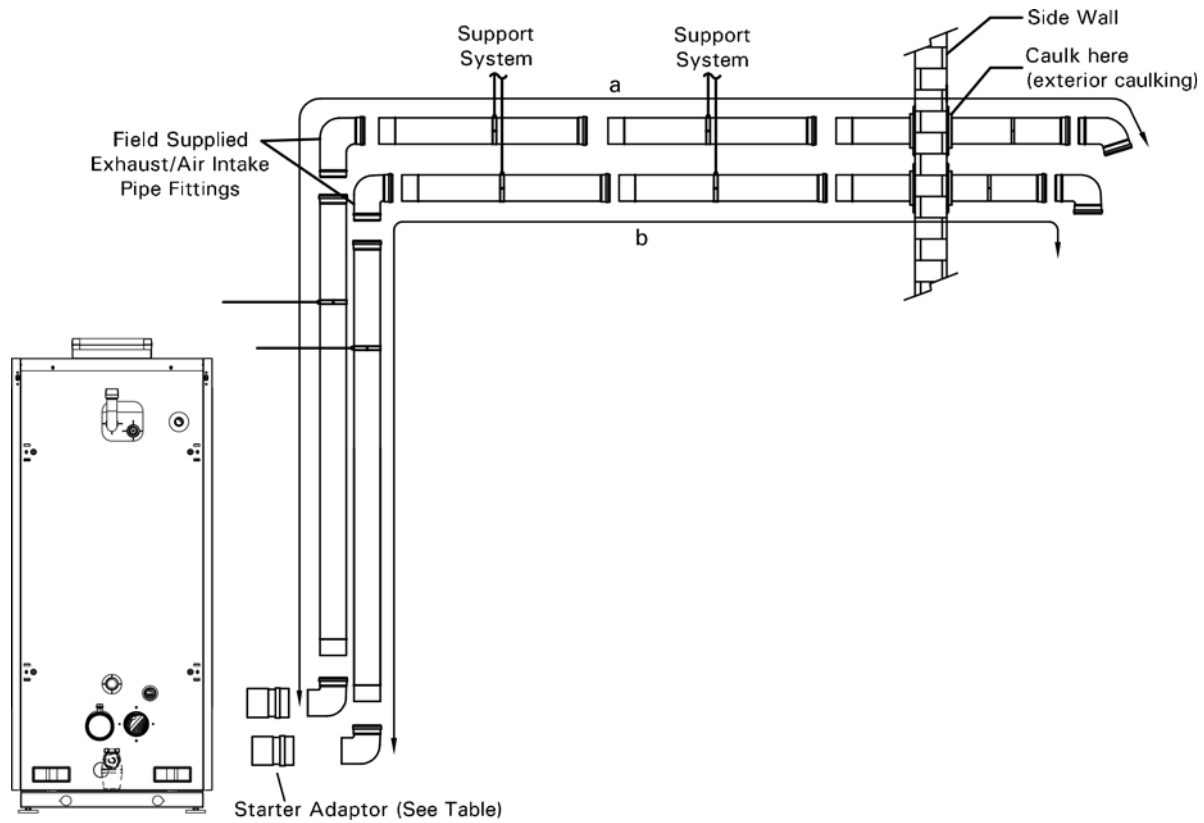

**Maximum equivalent length -
(horizontally or vertically vented)**

Boiler model	Intake Ø	Exhaust Ø	Equivalent length
CU3A 26, 35	3 in. (80 mm)	3 in. (80 mm)	198 ft. (60 m)
CU3A 45, 57	3 in. (80 mm)	4 in. (110 mm)	198 ft. (60 m)

A 7% boiler input reduction @ 60 m for all sizes and all configurations.

Component Parts of the Venting System - Stainless Steel

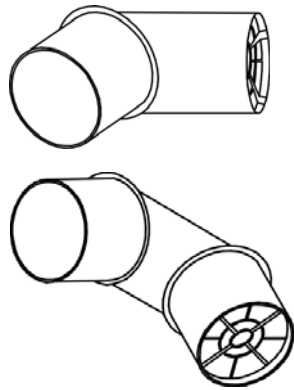

Termination Elbow with Screen 90° or 45°

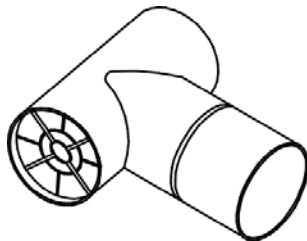

Termination Tee with Screen

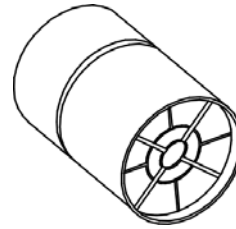

Termination Coupling with Screen

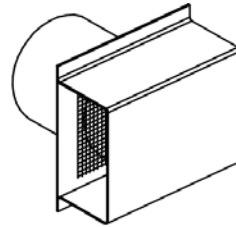

Termination Hood with Screen

Exhaust vent termination options (vertical installation)

Supplier	Boiler Model	Stainless Steel Slip Joint Starter Adaptor	Vertical Termination Coupling with Screen
Flexmaster	CU3A 26, 35	3 in. 2SVSVB03	3 in. 2SVST03
	CU3A 45, 57	4 in. 2SVSVB04	4 in. 2SVST04
Heat-Fab	CU3A 26, 35	3 in. 9301VSMN	3 in. 9392
	CU3A 45, 57	4 in. 9401VSMN	4 in. 9492
ProTech	CU3A 26, 35	3 in. 300568	3 in. 300186
	CU3A 45, 57	4 in. 300569	4 in. 300187
Security Chimneys	CU3A 26, 35	3 in. CTX-V3	Contact supplier
	CU3A 45, 57	4 in. CTX-V4	Contact supplier

Other exhaust vent termination options (horizontal installation)

Supplier	Boiler Model	Termination Elbow 90° or 45° with Screen	Termination Tee with Screen	Termination Hood with Screen
Flexmaster	CU3A 26, 35	Contact supplier	Contact supplier	Contact supplier
	CU3A 45, 57	Contact supplier	Contact supplier	Contact supplier
Heat-Fab	CU3A 26, 35	Contact supplier	Contact supplier	Contact supplier
	CU3A 45, 57	Contact supplier	Contact supplier	Contact supplier
ProTech	CU3A 26, 35	Contact supplier	Contact supplier	Contact supplier
	CU3A 45, 57	Contact supplier	Contact supplier	Contact supplier

These tables reflect the parts required if using special venting system for both exhaust vent and air intake pipe system. If using ABS/PVC/CPVC material for combustion air intake pipe, (refer to page 30 for proper starter adaptor for the system).

Vent Requirements - CPVC

Additional requirements for UL/ULC listed CPVC vent pipe material

Use UL/ULC listed special plastic pipe (CPVC) for horizontal (side wall) or vertical (roof) venting of the Vitocrossal 300 CU3A boilers.

See below and contact Viessmann to order special parts.

Exhaust vent/air intake connection to boiler

The vent connection to the Vitocrossal 300 CU3A boiler must be made with the CPVC starter adaptor. The starter adaptors are intended for a slip fit and slide into the boiler termination with a gentle twisting motion.

For vent/air intake pipe system, two wire mesh screens (bird screen) must be ordered from Viessmann. These parts are available in pre-cut diameters of 3 in. and 4 in.

Note: The Vitocrossal 300 CU3A boiler has passed the zero inches vent clearance to combustibles testing requirements dictated by the Harmonized Standard ANSI Z21.13. CSA 4.9 and therefore is listed for zero clearance to combustibles when vented with a single pipe special venting system (CPVC material). The zero inches vent clearance to combustibles for the Vitocrossal 300 CU3A boiler supersedes the clearance to combustibles listing that appears on the special venting system marking label.

 **WARNING**

The use of vent material other than listed CPVC, positive pressure vent pipe and fittings can cause property damage, severe personal injury and/or loss of life.

Required starter adaptors for CPVC system

Part	Boiler Model	Diameter	Supplier	Quantity
Flue gas pipe	CU3A 26, 35	3 in.	Viessmann	1
	CU3A 45, 57	4 in.		1
Wire Mesh Screen for Termination Elbows/Coupling	CU3A 26, 35	3 in.	Viessmann	2
	CU3A 45, 57	4 in.		2

The CPVC starter adaptor 3 in. for combustion air is supplied with the boiler installation fittings.

Vent and Air Intake Pipe Starter Adaptors - CPVC

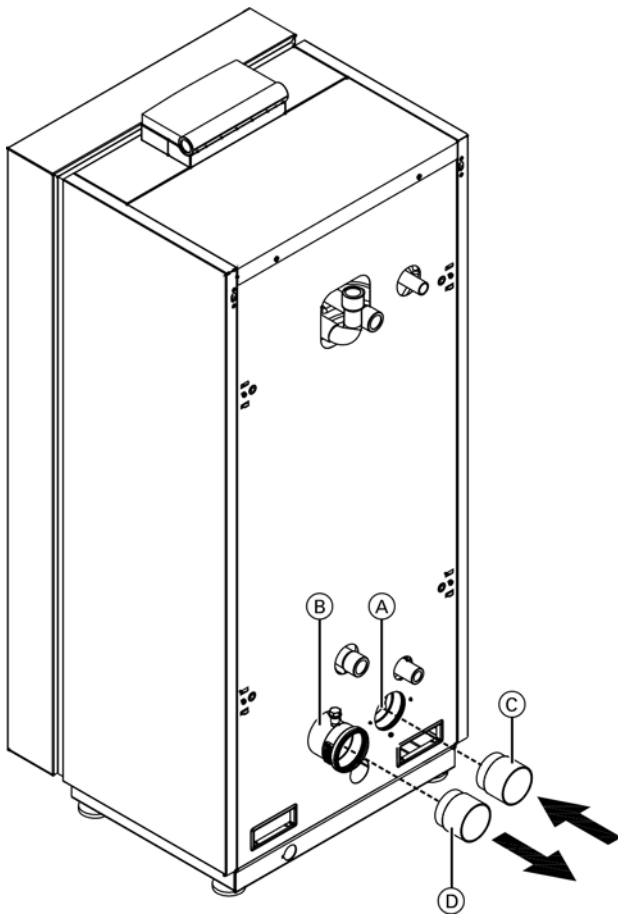

To install CPVC flue gas vent with Vitocrossal 300 CU3A boilers the CPVC flue gas adaptor (D) has to be ordered from Viessmann.

- CU3A 26, 35 3 in. (80 mm)
- CU3A 45, 57 4 in. (110 mm)

Legend

- (A) Combustion air intake
- (B) Flue gas outlet
- (C) Combustion air CPVC adaptor*
- (D) Flue gas CPVC adaptor

* A 3 in. combustion air CPVC adaptor is supplied with the boiler installation fittings.

Requirements for UL/ULC Listed Rigid PP(s) Vent Pipe Material

IMPORTANT

When replacing parts (use manufacturer’s original replacement parts).

The venting system must be installed by a licensed professional heating contractor familiar with the operation and maintenance of heating appliances and venting. Before installing this product, ensure that the complete installation literature has been read. Failure to follow proper installation procedures as stated in these instructions, including vent pitch and proper appliance connections, may violate local, provincial/state, or national codes and cause unsafe conditions which may lead to severe property damage or personal injury.

Prior to installation, check that the correct single-pipe vent parts were ordered and supplied.

The venting system must be installed in accordance with local building code requirements as well as national codes. For installations in Canada use CAN/CSA-B149.1 Natural Gas Installation Code or CAN/CSA-B149.2 Propane Installation Code as applicable; in the U.S. use the National Fuel Gas Code ANSI Z223.1 or NFPA Standard 54. Always use the latest edition of the applicable standard.

To ensure safe operation of the appliance, Viessmann recommends that the system be inspected once a year by a qualified service technician.

Every venting system must be planned and installed for optimum performance and safety. These Installation Instructions are designed to help you determine venting requirements and limitations with respect to installation. Please read and follow these instructions carefully.

It is the responsibility of the installer to contact local building and fire officials concerning any installation restrictions and/or inspection requirements that may apply. Permits may be required before commencement of the installation.

For Vitocrossal 300 CU3A 45, 57 (with boiler flue adaptor 110 mm to 100 mm) the vent manufacturers must supply transition adaptors.

The air intake termination for side wall air intake installations should be located on a wall that is least affected by prevailing winds. High winds may affect boiler operation.

Vent system manufacturers

The following listed PP(s) vent system manufacturers may be contacted for assistance in designing the appropriate venting system for Vitocrossal 300 CU3A boilers.

Listed manufacturers deliver PP(s) rigid vents in the required sizes.

M&G / Duravent www.duravent.com	Centrotherm InnoFlue www.centrotherm.us.com
PolyFlue - Selkirk www.polyflue.com	ECCO Manufacturing www.eccomfg.com
Z-FLEX US Inc. NovaFlex Group www.novaflex.com	

Because of its sealed combustion chamber, the Vitocrossal 300 CU3A gas-fired condensing boiler is suitable for operation with direct vent (two pipe systems).

The Vitocrossal 300 CU3A boiler, flue gas adaptor is approved together under CSA 4.9. ANSI Z21.13 Standard.

The venting system components are tested and listed to ULC S636 or UL 1738 and are marked and labelled on each component.

IMPORTANT

DO NOT mix pipe, fittings, or joining methods from different vent system manufacturers.

DO NOT use adhesives of any kind with this venting system.

The vent length requirements stated on pages 35, 36 and 37 in this manual must be observed.

Flue gases are discharged via rigid PP(s) vent components to the outdoors. This vent system is constructed from flame-retardant plastic [polypropylene rated for a maximum temperature of 230°F (110°C)].

Vent and Air Intake Pipe Starter Adaptors - PP(s)

Boiler vent terminals		
	Flue gas	Combustion air
CU3A 26, 35	3 in. (80 mm)	3 in. (80 mm)
CU3A 45, 57	4 in. (110 mm)	3 in. (80 mm)

Single PP(s) pipe sizes by manufacturers			
			Transition adaptor 110 to 100 required
M&G Duravent	3 in. (80 mm)	4 in. (100 mm)	✓
PolyFlue	3 in. (80 mm)	4 in. (100 mm)	✓
Z-Flex	3 in. (80 mm)	4 in. (110 mm)	--
Centrotherm	3 in. (80 mm)	4 in. (110 mm)	--
ECCO Mfg	3 in. (80 mm)	4 in. (110 mm)	--

Note: Vitocrossal 300 CU3A flue gas terminations are predesigned for PP(s) vent pipes. See vent manufacturers sizes.

Note: When using PP(s) material for combustion air supply, CPVC adaptors are not required.

Side Wall Vent Termination - Stainless Steel, CPVC or PP(s)

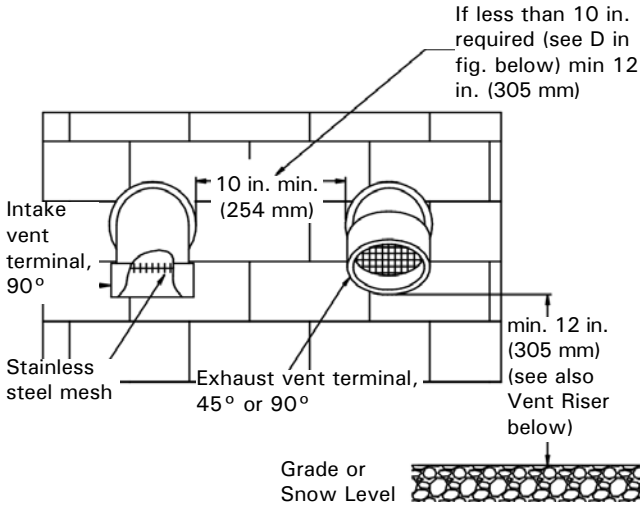

Side wall vent termination (front view)

IMPORTANT

The exhaust vent/air intake system must terminate so that proper clearances are maintained as cited in local codes or the latest edition of the "Natural Gas and Propane Installation Code" CAN/CSA-B149.1 (Canada), or the "National Fuel Gas Code" ANSI Z223.1 (NFPA 54) (U.S.A.). See page 7.

WARNING

Vent termination must be at least 12 in. (300 mm) above the anticipated snow level (consult your local building authorities or local weather office). Locate vent termination in such a way that it cannot be blocked by snow.

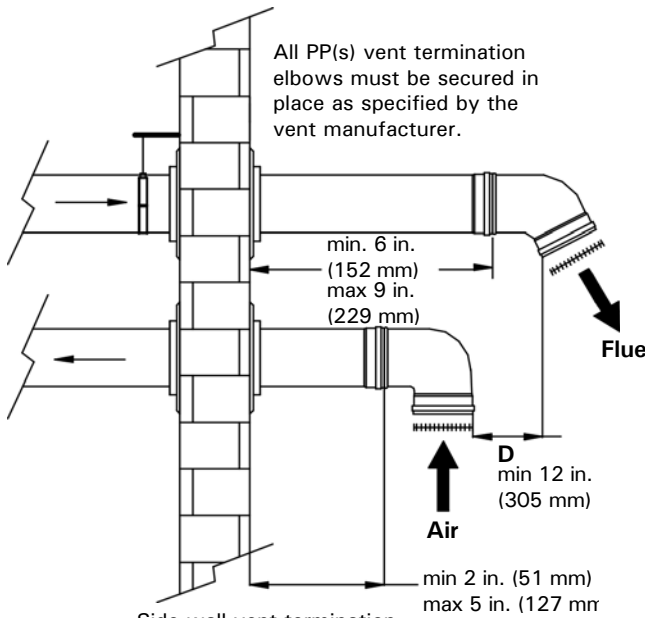

Side wall vent termination (side view)

IMPORTANT

For PP(s) systems, all exhaust vent and air intake piping and elbows exposed outside, must be UV resistant polypropylene (supplied by the vent manufacturer).

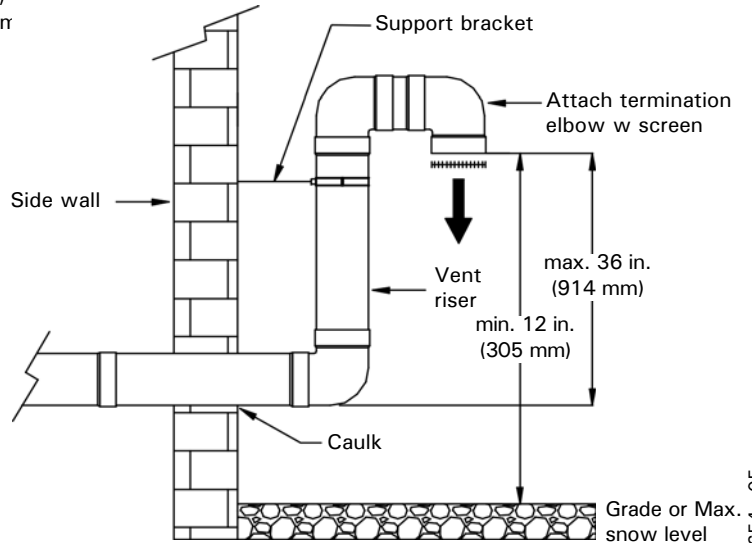

Installation of field fabricated vent riser

Vent Length Requirements

IMPORTANT

Always include vent termination length in calculations.

Note: For combination of different vent/air intake pipe diameters, such as Ø 4 in. stainless steel vent with Ø 3 in. (CVPC, PVC, ABS) air intake pipe, the total equivalent length must be used for the smaller pipe diameter.
Minimum vent length is 3.3 ft. (1 m).

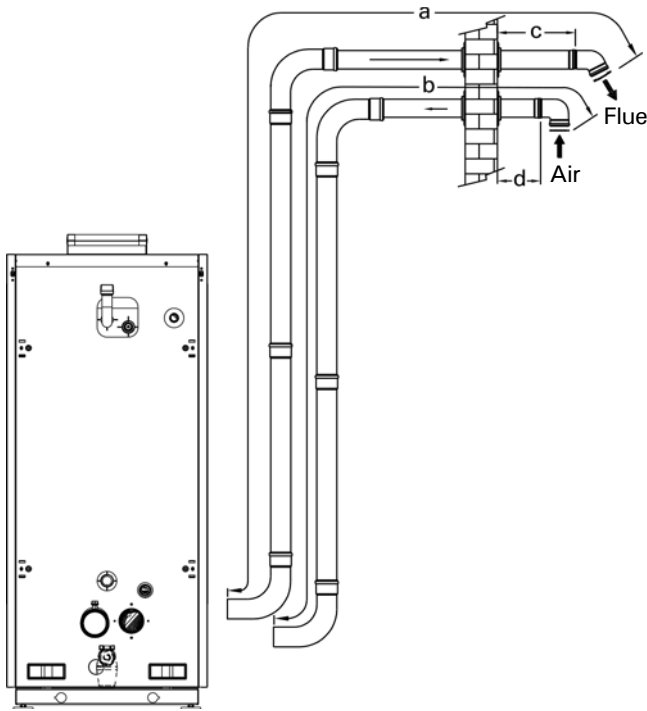

Legend

- a Equivalent vent length (exhaust)
- b Equivalent vent length (air intake)
- c Min. 6 in. (152 mm)
- d Min. 2 in. (50 mm)

Maximum vent/air intake pipe length - horizontal

The total equivalent length specified for a two pipe system consisting of stainless steel, CPVC or PP(s) is the total **combined** length of the exhaust vent and air intake pipe system.

Do not exceed these maximum lengths.

All PP(s) vent material and air intake (if PP(s) used) must be ULC S636 or UL1738 listed.

IMPORTANT

For PP(s) systems, all exhaust vent and air intake piping and elbows exposed outside, must be UV resistant polypropylene (supplied by the vent manufacturer).

Maximum equivalent length - horizontal

Boiler model	Intake Ø	Exhaust Ø	Equivalent length
CU3A 26, 35	3 in. (80 mm)	3 in. (80 mm)	198 ft. (60 m)
CU3A 45, 57	3 in. (80 mm)	4 in. (110 mm)	198 ft. (60 m)

A 7% boiler input reduction @ 60 m for all sizes and all configurations.

Flashing and storm collar installation

Flashings and storm collars are field supplied. Flashings and storm collars suitable for Type B vent materials (or better) may be used.

To obtain flashings and storm collars, please contact your local vent material supplier. Follow the installation instructions supplied by the special venting manufacturer.

Follow local codes to properly isolate the exhaust vent pipe when passing through floors, ceiling and roof.

Always check the marking on the pipe to make sure you are using the correct material.

Vent Length Requirements *(continued)*

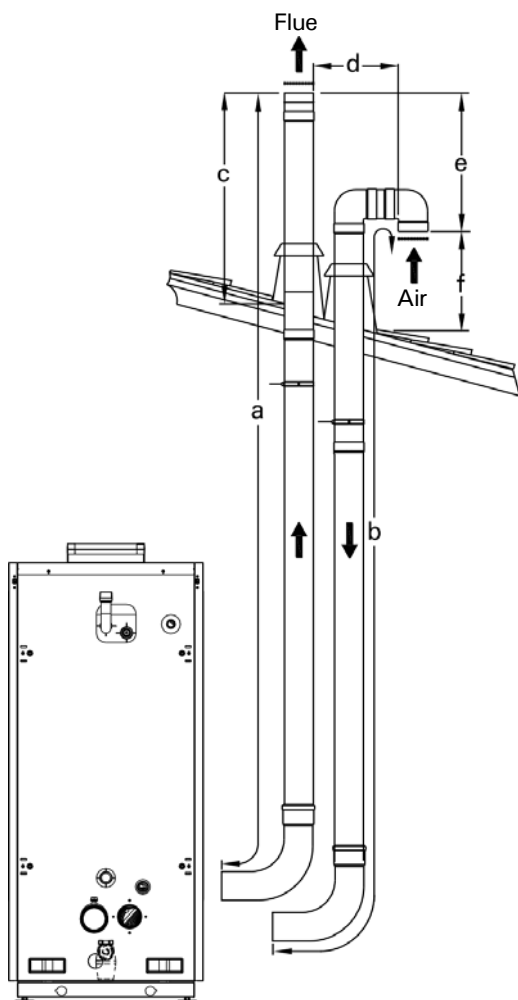

Legend

- a Equivalent length (exhaust)
- b Equivalent length (air intake)
- c min. 18 in. (457 mm) / max. 48 in. (1219 mm)
- d min. 12 in. (305 mm)
- e min. 12 in. (305 mm)
- f 12 in. (305 mm) over max. local snow level (check with your local weather office for details)

Maximum vent/air intake pipe length - vertical

Note: For combination of different vent/air intake pipe diameters, such as Ø 4 in. stainless steel vent with Ø 3 in. (PP(s), CVPC, PVC, ABS) air intake pipe, the total equivalent length must be used for the smaller pipe diameter.

Minimum vent length is 3.3 ft. (1 m).

IMPORTANT

All PP(s) vent termination elbows, must be secured in place as specified by manufacturer.

IMPORTANT

For PP(s) systems, all exhaust vent and air intake piping and elbows exposed outside, must be UV resistant polypropylene (supplied by the vent manufacturer).

The total equivalent length specified for a two pipe system is the total **combined** length of the exhaust vent and air intake pipe system. Do not exceed these maximum lengths. All PP(s) vent material and air intake (if PP(s) used) must be ULC S636 listed.

Maximum equivalent length - vertical

Boiler model	Intake Ø	Exhaust Ø	Equivalent length
CU3A 26, 35	3 in. (80 mm)	3 in. (80 mm)	198 ft. (60 m)
CU3A 45, 57	3 in. (80 mm)	4 in. (110 mm)	198 ft. (60 m)

A 7% boiler input reduction @ 60 m for all sizes and all configurations.

Flashing and storm collar installation

Flashings and storm collars are field supplied. Flashings and storm collars suitable for Type B vent materials (or better) may be used.

To obtain flashings and storm collars, please contact your local vent material supplier. Follow the installation instructions supplied by the special venting manufacturer.

Follow local codes to properly isolate the exhaust vent pipe when passing through floors, ceiling and roof.

Always check the marking on the pipe to make sure you are using the correct material.

Vent Length Requirements *(continued)*

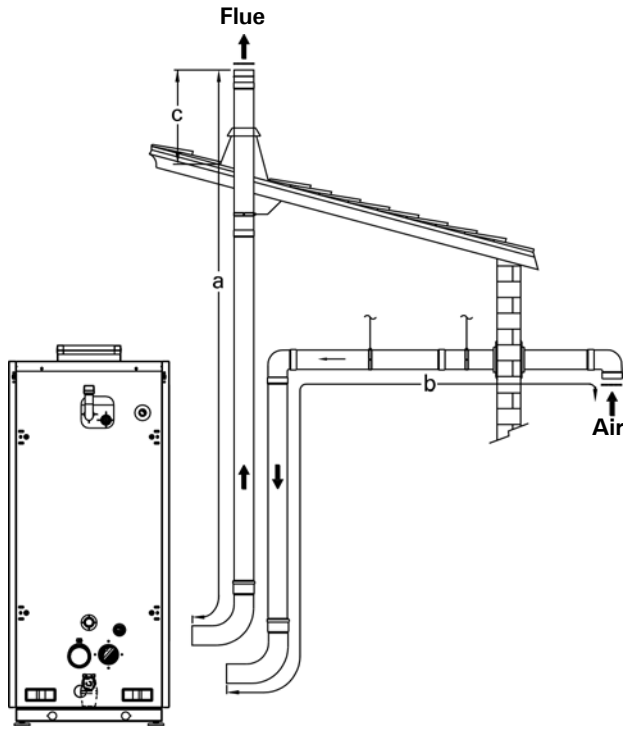

Legend

- a Equivalent length (exhaust)
- b Equivalent length (air intake)
- c min. 18 in. (max. 48 in.)

Maximum vent/air intake pipe length - horizontal/vertical (hybrid system)

All PP(s) vent material and air intake (if PP(s) used) must be ULC S636 or UL1738 listed.

The total equivalent length specified for a two pipe system is the total **combined** length of the exhaust vent and air intake pipe system. Do not exceed these maximum lengths.

Note: For combination of different vent/air intake pipe diameters, such as Ø 4 in. stainless steel vent with Ø 3 in. (CVPC, PVC, ABS) air intake pipe, the total equivalent length must be used for the smaller pipe diameter.

Minimum vent length is 3.3 ft. (1 m).

Maximum equivalent length - vertical exhaust / horizontal air intake (hybrid)

Boiler model	Intake Ø	Exhaust Ø	Equivalent length
CU3A 26, 35	3 in. (80 mm)	3 in. (80 mm)	198 ft. (60 m)
CU3A 45, 57	3 in. (80 mm)	4 in. (110 mm)	198 ft. (60 m)

A 7% boiler input reduction @ 60 m for all sizes and all configurations.

Flashing and storm collar installation

Flashings and storm collars are field supplied. Flashings and storm collars suitable for Type B vent materials (or better) may be used.

To obtain flashings and storm collars, please contact your local vent material supplier. Follow the installation instructions supplied by the special venting manufacturer.

Follow local codes to properly isolate the exhaust vent pipe when passing through floors, ceiling and roof.

Always check the marking on the pipe to make sure you are using the correct material.

Vent Length Requirements *(continued)*

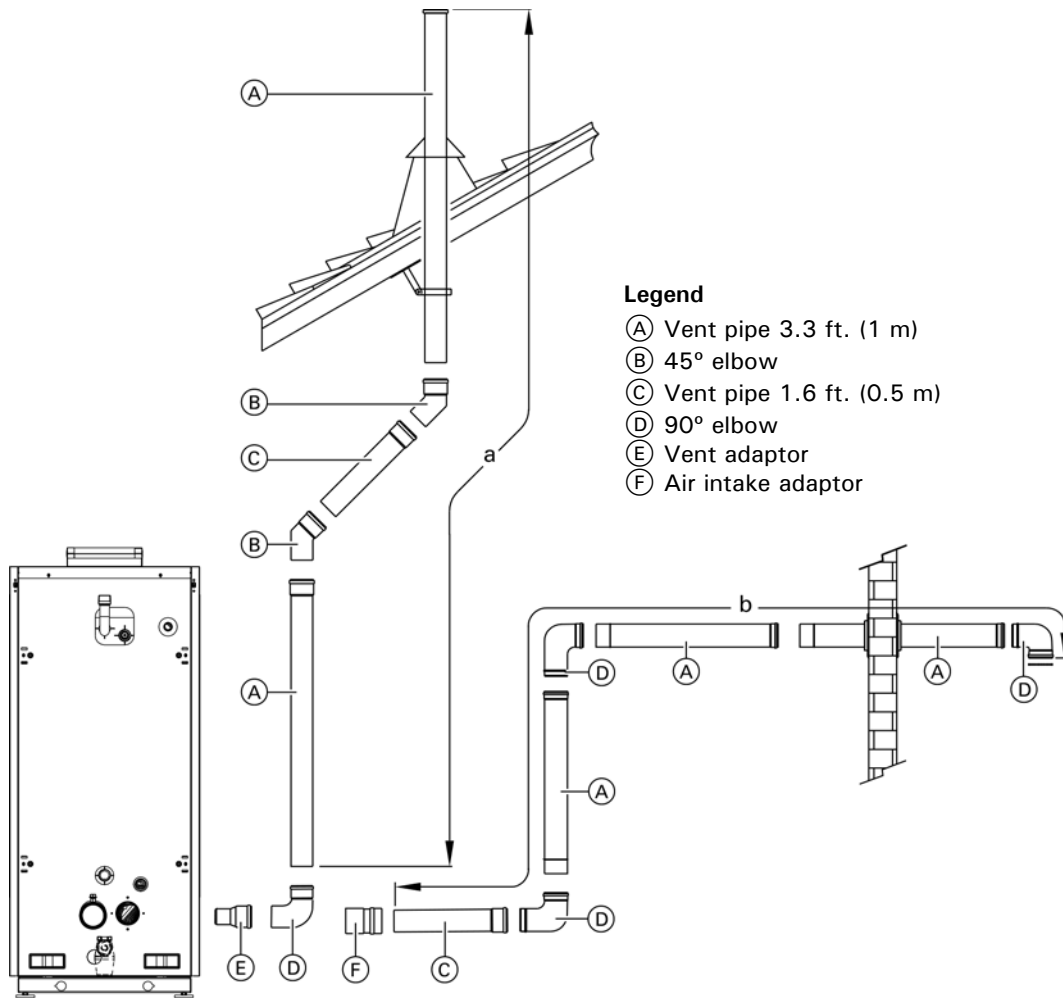

IMPORTANT

Always include vent termination length in calculations.

Equivalent vent length calculation example
(Vitocrossal 300 CU3A 26/35 systems diameter 3 in.)

Maximum allowable equivalent length is 198 ft. (60 m)

- 2 x 90° stainless steel elbow.....6 ft. (1.83 m)
- 2 x 45° stainless steel elbow.....4 ft. (1.22 m)

Air intake pipe

- 1 x 90° plastic (ABS/CPVC/PVC) elbow.....5 ft. (1.52 m)
- 1 x 45° plastic (ABS/CPVC/PVC) elbow.....3 ft. (0.91 m)
- Exhaust vent pipe.....10 ft. (3.05 m)
- Air intake pipe.....10 ft. (3.05 m)
- Combined total equivalent vent length
- (a + b).....38 ft. (11.58 m)

Standard long sweep elbows

Material	90° elbow equivalent length ft. (m)	45° elbow equivalent length ft. (m)	87° elbow / inspection tee ft. (m)
Stainless steel	3 (0.91)	2 (0.61)	-
CPVC, ABS, PVC plastic pipe	5 (1.52)	3 (0.91)	-
PP(s)	-	1 (0.30)	1.6 (0.50)

Standard long sweep elbows (for CPVC pipe only)

Note: If standard sweep elbows are used the allowable vent lengths are reduced. One standard 90° elbow is equivalent to 8 ft. (2.4 m) of straight pipe. Long sweep elbows are recommended for use with venting system.

Vent Length Requirements *(continued)*

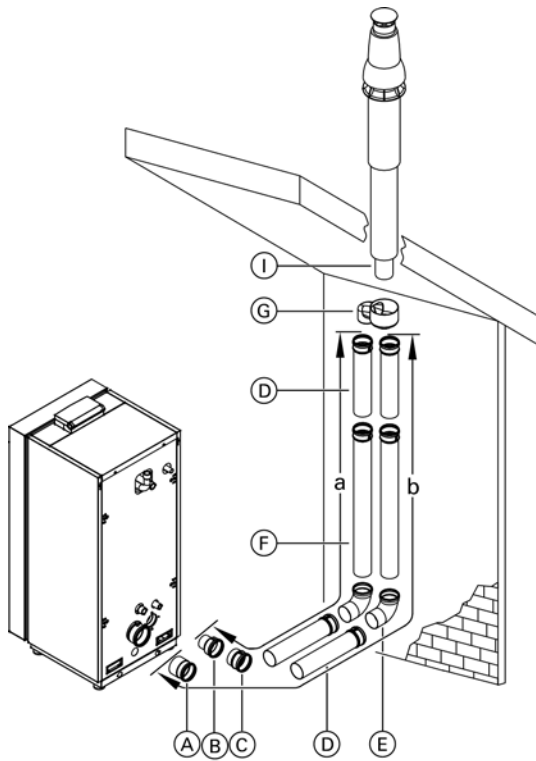

Two pipe system with coaxial termination only

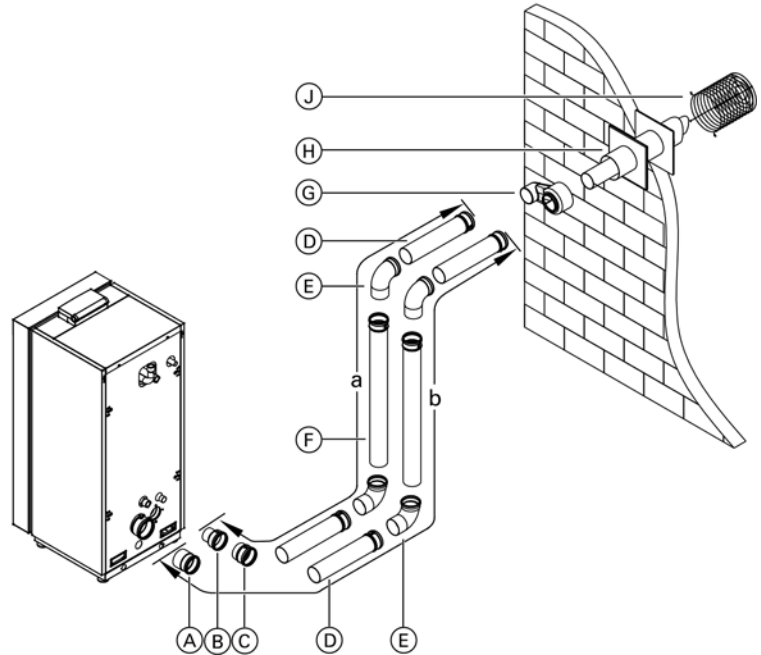

Legend

- (A) Vent adaptor 110 to 100 mm (if required)
- (B) Increaser 80 to 100 mm (if required) field supplied
- (C) Adaptor (if required)
- (D) Short vent length 1.6 ft. (0.5 m)
- (E) Elbow 90°
- (F) Long vent length 3.3 ft. (1 m)
- (G) Coaxial adaptor (supplied by vent manufacturer)
- (H) Horizontal coaxial termination
- (I) Vertical coaxial termination
- (J) Bird screen

IMPORTANT

Always include vent termination length in calculations.

Equivalent vent length calculation example
(Vitocrossal 300 CU3A 26/35 systems diameter 3 in.)

- 2 x 90° stainless steel elbow.....6 ft. (1.83 m)
- 2 x 45° stainless steel elbow.....4 ft. (1.22 m)

Air intake pipe

- 1 x 90° plastic (ABS/CPVC/PVC) elbow.....5 ft. (1.52 m)
- 1 x 45° plastic (ABS/CPVC/PVC) elbow.....3 ft. (0.91 m)
- Exhaust vent pipe.....10 ft. (3.05 m)
- Air intake pipe.....10 ft. (3.05 m)

Combined total equivalent vent length
(a + b).....38 ft. (11.58 m)

Standard long sweep elbows

Material	90° elbow equivalent length ft. (m)	45° elbow equivalent length ft. (m)	87° elbow / inspection tee ft. (m)
Stainless steel	3 (0.91)	2 (0.61)	-
CPVC, ABS, PVC plastic pipe	5 (1.52)	3 (0.91)	-
PP(s)	-	1 (0.30)	1.6 (0.50)

Standard long sweep elbows (for CPVC pipe only)

Note: If standard sweep elbows are used the allowable vent lengths are reduced. One standard 90° elbow is equivalent to 8 ft. (2.4 m) of straight pipe. Long sweep elbows are recommended for use with venting system.

Maximum equivalent length - vertical exhaust / horizontal air intake (hybrid)

Boiler model	Intake Ø	Exhaust Ø	Equivalent length
CU3A 26, 35	3 in. (80 mm)	3 in. (80 mm)	198 ft. (60 m)
CU3A 45, 57	3 in. (80 mm)	4 in. (110 mm)	198 ft. (60 m)

A 7% boiler input reduction @ 60 m for all sizes and all configurations.

Flue Vent Termination Requirements

Multiple boiler installations (vertical flue termination)

When terminating the vertical vent pipes of multiple Vitocrossal 300 CU3A boilers, a minimum clearance of 4 inches (100 mm) is required between the outside edges of each vent pipe.

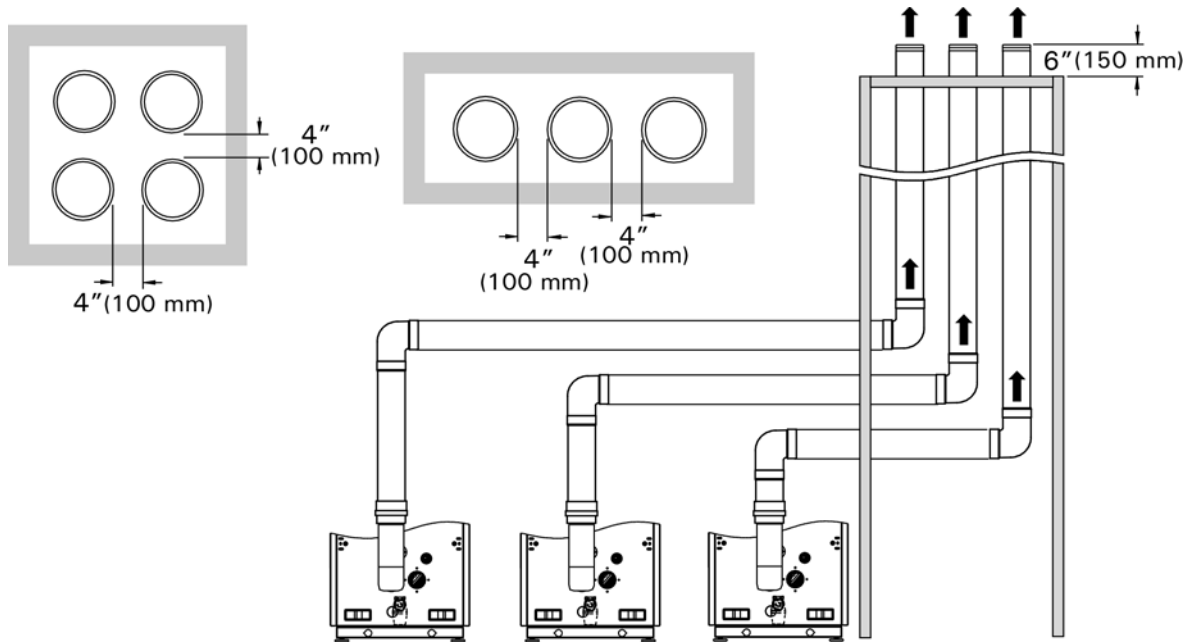

Multiple boiler installations (horizontal flue termination)

When terminating the horizontal vent pipes of multiple Vitocrossal 300 CU3A boilers, a minimum clearance of 12 inches (305 mm) is required between the outside edges of each vent pipe.

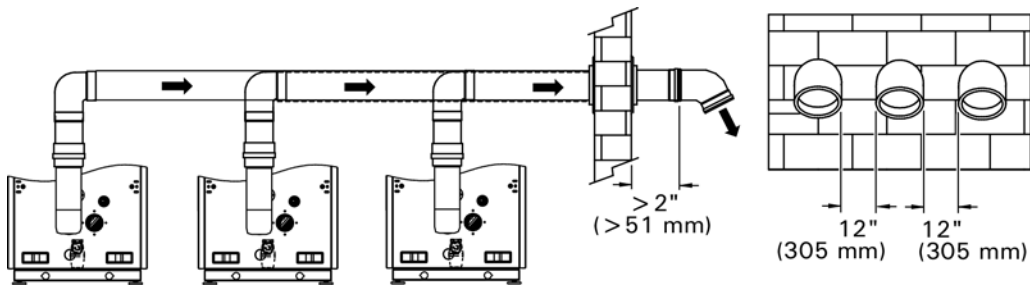

Note: termination elbows can be 45° or 90°.

Component Parts of the PP(s) Venting System *(continued)*

Horizontal pipe system

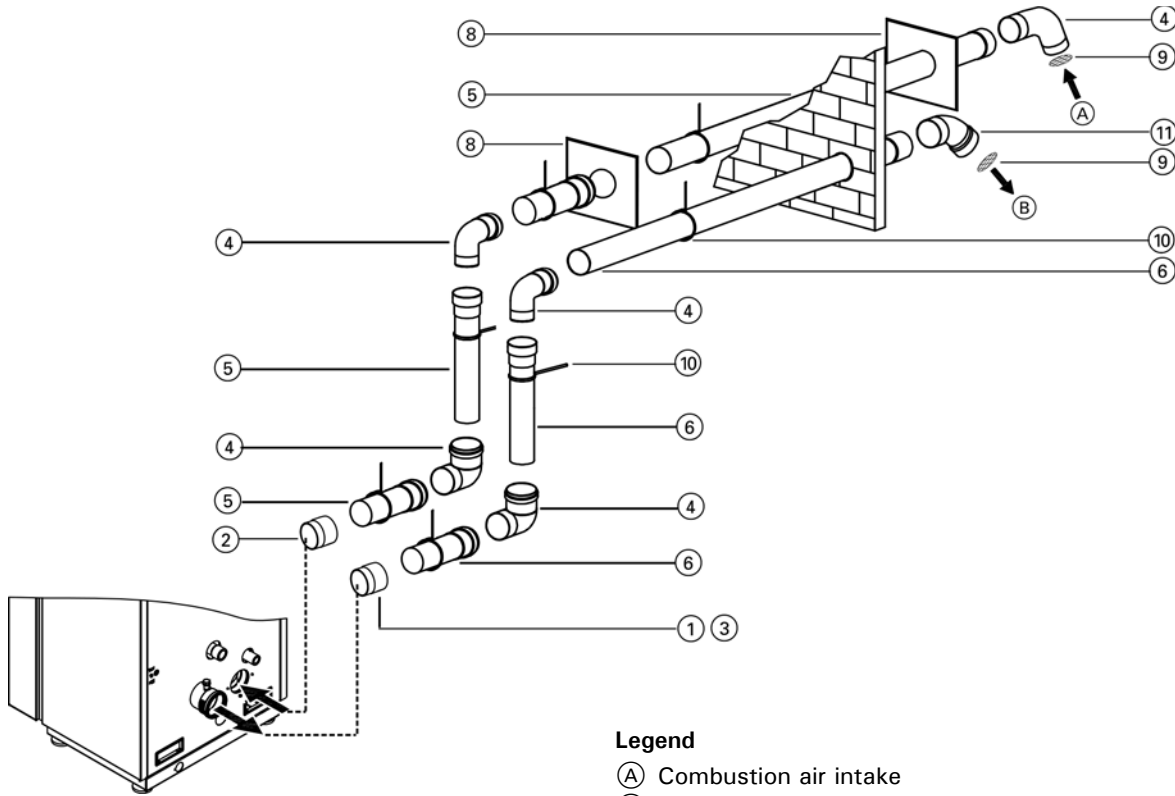

Legend

- (A) Combustion air intake
- (B) Flue gas outlet
- (1) Boiler vent pipe adaptor
- (2) Air intake adaptor (PVC, CPVC, ABS)
- (3) PP(s) adaptor (110 mm to 100 mm when using M&G system with Vitocrossal 300 CU3A 45 or 57)
- (4) 90° elbows
- (5) Combustion air intake straight pipe
- (6) Straight vent pipe
- (7) Pipe support
- (8) Wall plate
- (9) Bird screen
- (10) Wall strap with locking band at each joint, as supplied by manufacturer.
- (11) 45° elbows

IMPORTANT

For PP(s) systems, all exhaust vent and air intake piping and elbows exposed outside, must be UV resistant polypropylene (supplied by the vent manufacturer).

Venting - Single Pipe (Room Air Dependent)

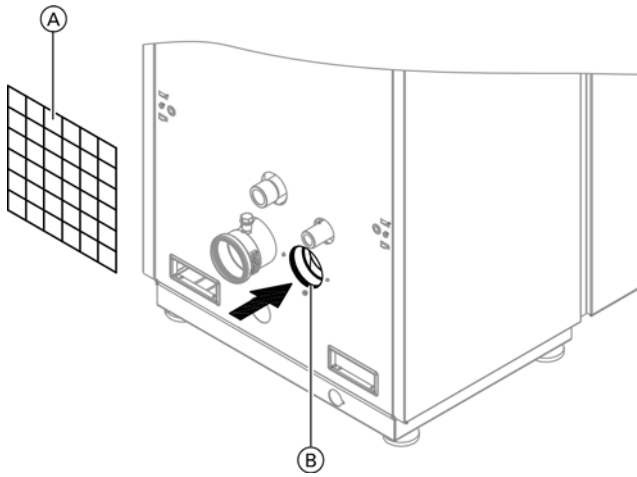

This system draws combustion air from the boiler room.

Legend

- Ⓐ Combustion air opening (room)
- Ⓑ Combustion air intake

IMPORTANT

Refer to the local code regulations regarding combustion air open requirements.

Vent Requirements

Combustion air supply

This boiler requires fresh air for safe operation and must be installed in a mechanical room where there are provisions for adequate combustion and ventilation air.

There are no provisions available on the Vitocrossal 300 CU3A boiler to interlock it with an external combustion air blower.

The Vitocrossal 300 CU3A boiler is suitable for sidewall, as well as vertical venting using field supplied venting material. The Vitocrossal 300 CU3A boilers are approved for direct exhaust (non-sealed combustion) operation in both, horizontal and vertical arrangements.

Provisions for combustion and ventilation air must be made in accordance with CAN/CSA-B149.1 or .2 Natural Gas Installation Codes (for installations in Canada) or in accordance with sections for Combustion and Ventilation Air, of the National Fuel Gas Code, ANSI Z223.1 or applicable provisions of local codes (for installations in the U.S.A.) Always use the latest edition of the applicable standard.

Follow local codes to properly isolate the vent pipe when passing through floors, ceilings and roof.

Whenever possible, install boiler near an outside wall so that it is easy to duct fresh air directly to the boiler area. Refer to national codes for duct sizing. Round ducts may be used.

The boiler must be vented and supplied with combustion air and exhaust vents as described in this section. Ensure the vent and combustion air supply comply with these instructions.

The boiler location should never be under negative pressure. Exhaust fans, attic fans, or dryer fans may cause air to be exhausted at a rate higher than the air can enter the structure for safe combustion. Corrective action must be taken to ensure enough air is available. Never cover the boiler or store debris or other materials near the boiler, or in any way block the flow of adequate fresh combustion air to the boiler.

If boiler is installed in a confined space (a space with a volume of less than 50 cubic feet per 1000 Btu/h of gas input for all fuel burning equipment) or building layout is unusually tight, adequate air for combustion must be provided by two openings: one located about 6 in. below the ceiling, the other about 6 in. above the floor.

When communicating directly with the outside, each opening must have a minimum free area of one square inch per 2000 Btu/h of gas input. When all combustion air is provided by openings in doors, etc. to adjoining spaces having adequate infiltration, each opening must have a minimum free area of one square inch per 1000 Btu/h of gas input, but not less than 100 in².

You must know the free area of louvers used to cover up the combustion and ventilation openings in closet installations. If you do not know the free area, assume 20% for wood louvers and 60-75% free area for metal louvers. When using louvers, the openings have to be made larger. For example, a free 14 in. x 6 in. opening becomes a 14 in. x 10 in. opening for a grill containing metal louvers.

! WARNING
Failure to provide an adequate supply of fresh combustion air can cause poisonous flue gases to enter living space, which can cause severe personal injury or loss of life.

! CAUTION
Do not store chemicals containing chlorine or other corrosive materials near the boiler, such as bleach, cleaning solvents, detergents, acids, hair spray, spray cans, paint thinners, paint, water softener salt, perchloroethylene, or carbon tetra chloride.

Vent Requirements *(continued)*

Combustion air supply *(continued)*

Inspect all finished exhaust vent piping to ensure:

- Vent pipe and fittings are of approved material.
- Acceptable size, length and number of elbows on combined vent pipe system.
- Installation is in accordance with prevailing provisions of local codes.
- Installation complies with the requirements of these instructions, as well as the exhaust vent supplier's instructions.

The exhaust vent system and terminations may be installed in one of the following types of terminations:

1. Horizontal exhaust vent
2. Vertical exhaust vent

 **CAUTION**

Exposure to corrosive materials can cause heat exchanger corrosion and failure.

 **CAUTION**

Do not locate boiler in areas where high dust levels or high humidity levels are present.

 **CAUTION** *

Do not install boiler during construction involving drywall or heavy dust of any kind. Dust can accumulate in the burners and cause sooting. Install boiler after all heavy dust construction is completed.

* Typically when the boiler is used as a temporary heat source during the building construction phase.

 **CAUTION**

If the boiler has been exposed to high dust levels, all burners and the heat exchanger must be cleaned prior to use.

Note: If above criteria are not properly observed and boiler damage results, any warranty on the complete boiler and related components will be null and void.

General Installation Information

 **WARNING**

Failure to provide an adequate supply of fresh combustion air can cause poisonous flue gases to enter living space, which can cause severe personal injury or loss of life.

Viessmann recommends that the entire vent system be checked by a licensed professional heating contractor at least once each year following initial installation.

The remaining space surrounding a chimney liner, gas vent, or special gas vent or plastic piping installed within a masonry, metal or factory-built flue shall not be used to supply combustion air.

The stainless steel special venting system is completely sealed when fully assembled. Locking bands are used to reinforce the joints between pipe and fittings.

 **WARNING**

Different manufacturers offer a number of different joint systems and adhesives. Do not mix pipes, fittings and/or joining methods from different manufacturers. Failure to comply could result in leakage, potentially causing personal injury or death.

Do not install vent pipe such that flue gases flow downwards. The direction of flue gas flow must be vertically upwards or horizontal with an upward slope.

Ensure there is no flue gas leakage into the area in which the boiler is installed.

Check joints for leaks with the gas supply turned off and the fan running. Use a soapy solution to check for vent leaks.

Condensate must drain from the flue pipe to the boiler. Ensure a suitable gradient of at least 3° [approx. 2 in. per 3.3 ft. (50 mm per 1 m)].

No condensate trap is required in the vent pipe system.

General Installation Information *(continued)*

Installation steps (outline)

Exhaust vent pipe material

Use only the materials listed in the table on page 45 for exhaust vent pipe fittings.

- Cut the pipe end square and remove all burrs and debris from joints and fittings.
- If using CPVC special vent material for exhaust vent pipe, all joints must be properly cleaned, primed and cemented. Use only cement and primer approved for the use with the pipe material. See table on page 46 for approved solvent cement material.

CAUTION

For solvent cement and primer:

- Use only in well ventilated areas
- Do not use near flame or open fire
- Use only the solvent cement and primer appropriate for the venting material being used
- Solvent cements for plastic pipe are flammable liquids and must be kept away from all sources of ignition

- No low point is allowed in the exhaust vent pipe system, unless a proper drain pipe is used to allow condensate to drain.
- All PP(s) vent material (if PP(s) used) must be ULC S636 or UL1738 listed.

WARNING

Ensure that the entire venting system is protected from physical damage. A damaged venting system may cause unsafe conditions.

WARNING

The venting system is approved for indoor installations only. Do not install the venting system outdoors.

- Route vent pipe as directly as possible and with as few bends as possible to the boiler.
- Condensate must drain from the flue pipe to the boiler. Ensure a suitable gradient of at least 3° [approx. 2 in. per 3.3 ft. (50 mm per 1 m)].
- Use a hacksaw or sheet metal snips (for stainless steel to cut pipes to length (if necessary)). Use a file to smooth rough edges. Pipe must be round and not bent into an oval shape.
- Check proper location of gaskets in rigid PP(s) pipe collars. (Only use supplied parts with the polypropylene venting system.) Apply water to lubricate the joint ends of the vent pipe collar and if used, the air intake pipe collar.
- Slide pipes into each other with a gentle twisting motion.

IMPORTANT

When cutting pipes to length, debur and clean pipes.

In conjunction with these instructions, follow the installation instructions supplied by the special venting manufacturer.

- All piping must be fully supported. Use pipe hangers at a minimum of 48 in. (1219 mm) intervals to prevent sagging of the pipe.
- The exhaust vent pipe and fittings must be securely supported by a support system suitable for the weight and design of the material employed. Contact your local vent material supplier for more information specific to your installations.

IMPORTANT

Ensure that the exhaust vent pipes are properly supported. The Vitocrossal 300 CU3A boiler is not designed to support the weight of the exhaust vent pipe system.

- Field supplied increaser fittings (transitions) should always be made in vertical sections of pipe to prevent accumulation of condensate in the vent pipe.
- If exhaust vent pipe system passes through an unheated space, such as an attic, it must be insulated. The insulation must have an R value sufficient to prevent freezing of the condensate. Armaflex insulation with ½ in. thickness and higher can be used.

General Installation Information *(continued)*

Approved materials for single pipe vent system

Part	Material	Certified to Standards	Applicability
Exhaust pipe and fitting	Stainless steel	UL1738 "Venting systems for gas-burning appliances, Categories II, III, IV"	U.S.A./Canada
		ULC S636 "standard for Type BH gas venting systems"	
	CPVC	UL1738 "Venting systems for gas-burning appliances, Categories II, III, IV"	
		ULC S636 "standard for Type BH gas venting systems" Class IIB 90°C	
	PP(s)	UL1738 "Venting systems for gas-burning appliances, Categories II, III, IV"	
		ULC S636 "standard for Type BH gas venting systems" Class IIC 110°C	
Pipe cement, primer (for exhaust pipe and fitting)	CPVC	ULC S636 "Standard for Type BH gas venting systems" Class IIB 90°C	

 **CAUTION**
Do not use cellular (foam) core pipe material to vent the Vitocrossal 300 CU3A boiler.

 **CAUTION**
Do not use PVC material in exhaust system.

Support system

The venting system must be securely supported by a support system suitable for the weight and design of the materials employed.

The Vitocrossal 300 CU3A boiler is not designed to support the weight of the venting system.

Use supports to transfer the weight of an installation to the building structure. There are different types of supports available and their capacity varies with each type and diameter.

The following support types are available at your local vent material supplier...

- anchor plate
- wall support
- roof support
- floor support
- suspension band (hanger).

In addition to the support types listed, mounting clips can be used to support the weight of the venting system.

Contact your vent material supplier for more information specific to your installation.

Follow the installation instructions supplied by the special venting manufacturer.

Flashing and storm collar installation

Flashings and storm collars are field supplied. Flashings and storm collars suitable for Type B vent materials (or better) may be used.

To obtain flashings and storm collars, please contact your local vent material supplier. Follow the installation instructions supplied by the special venting manufacturer.

Follow local codes to properly isolate the exhaust vent pipe when passing through floors, ceiling and roof.

Always check the marking on the pipe to make sure you are using the correct material.

Vent Requirements - Stainless Steel

Exhaust vent termination options

Supplier	Boiler Model	Stainless Steel Slip Joint Starter Adaptor	Vertical Termination Coupling with Screen
Flexmaster	CU3A 26, 35	3 in. 2SVSVB03	3 in. 2SVSVT03
	CU3A 45, 57	4 in. 2SVSVB04	4 in. 2SVSVT04
Heat-Fab	CU3A 26, 35	3 in. 9301VSMN	3 in. 9392
	CU3A 45, 57	4 in. 9401VSMN	4 in. 9492
ProTech	CU3A 26, 35	3 in. 300568	3 in. 300186
	CU3A 45, 57	4 in. 300569	4 in. 300187
Security Chimneys	CU3A 26, 35	3 in. CTX-V3	Contact supplier
	CU3A 45, 57	4 in. CTX-V4	Contact supplier

Note: Minimum vent pipe diameter with stainless steel vent system is 3 in. (80 mm).

Additional requirements for stainless steel vent pipe material

Use a special stainless steel venting system (UL/ULC listed for category IV) for horizontal or vertical venting of the Vitocrossal 300 CU3A boilers.

Contact one of the suppliers (see listing below) to order.

Prior to installation, check that the correct single-pipe vent parts were ordered and supplied.

See exhaust vent termination chart for special stainless steel single-pipe vent starter adaptor, coaxial increasers and bird screen models required for your installation.

In case of discrepancies, contact original parts supplier.

Exhaust vent pipe connection to boiler

The vent connection to the Vitocrossal 300 CU3A boiler must be made with a starter stainless steel adaptors (supplied by others). The starter adaptors are intended for a slip fit and slide into the boiler flue gas port with a gentle twisting motion.

Note: The Vitocrossal 300 CU3A boiler has passed the zero inches vent clearance to combustibles testing requirements dictated by the Harmonized Standard ANSI Z21.13, CSA 4.9 and therefore is listed for zero clearance to combustibles when vented with a single pipe special venting system.

The zero inches vent clearance to combustibles for the Vitocrossal 300 CU3A boiler supersedes the clearance to combustibles listing that appears on the special venting system label.

Component Parts of the Venting System (stainless steel)

Note: Product may not appear exactly as shown.

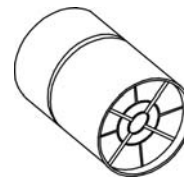

Termination Coupling with Screen

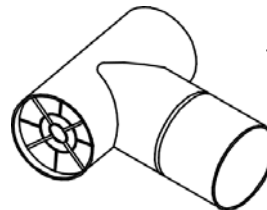

Termination Tee with Screen

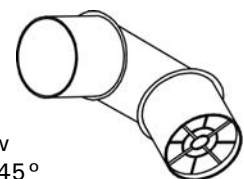
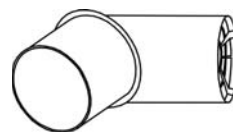

Termination Elbow with Screen 90° or 45°

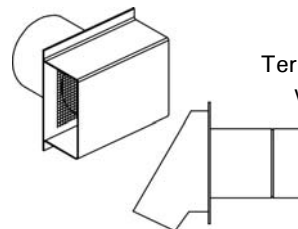

Termination Hood with Screen

Vent system manufacturers

Flexmaster Canada Ltd. www.novaflex.com	ICC - Industrial Chimney Co. www.icc-rsf.com
ProTech Systems, Inc. www.protechinfo.com	Heat-Fab, Inc. www.selkirkcorp.com
Security Chimneys International Ltd. www.securitychimneys.com	Z-FLEX US Inc. NovaFlex Group www.novaflex.com

Vent Requirements - CPVC

Additional requirements for CPVC vent pipe material

Use UL/ULC listed special plastic pipe (CPVC) for horizontal (side wall) or vertical (roof) venting of the Vitocrossal 300 CU3A boilers.

Prior to installation, check that the correct single-pipe vent parts have been ordered and supplied.

See table for special starter adaptor and bird screen models required for your installation.

Exhaust vent connection to boiler

The vent connection to the Vitocrossal 300 CU3A boiler must be made with CPVC starter adaptors (see table). The starter adaptors are intended for a slip fit and slide into the boiler adaptor with a gentle twisting motion.

For a vent pipe system, one wire mesh screen (bird screen) must be ordered from Viessmann. These parts are available in pre-cut diameters of 3 in. and 4 in.

Required starter adaptors and mesh screen for CPVC system

Part	Boiler	Size	Supplier	Qty
CPVC Starter Adaptor	CU3A 26, 35	3 in.	Viessmann	1
	CU3A 45, 57	4 in.		
Wire Mesh Screen for Termination Elbows/Coupling	CU3A 26, 35	3 in.	Viessmann	1
	CU3A 45, 57	4 in.		



WARNING

The use of vent material other than materials approved for, positive pressure vent pipe and fittings can cause property damage, severe personal injury and/or loss of life.

Note: The Vitocrossal 300 CU3A boiler has passed the zero inches vent clearance to combustibles testing requirements dictated by the Harmonized Standard ANSI Z21.13 CSA 4.9 and therefore is listed for zero clearance to combustibles when vented with a single pipe special venting system (CPVC material). The zero inches vent clearance to combustibles for the Vitocrossal 300 CU3A boiler supersedes the clearance to combustibles listing that appears on the special venting system marking label.

Requirements for UL/ULC Listed Rigid PP(s) Vent Pipe Material

IMPORTANT

When replacing parts, use original manufacturer replacement parts.

The venting system must be installed by a licensed professional heating contractor familiar with the operation and maintenance of heating appliances and venting. Before installing this product, ensure that the complete installation literature has been read. Failure to follow proper installation procedures as stated in these instructions, including vent pitch and proper appliance connections, may violate local, provincial/state, or national codes and cause unsafe conditions which may lead to severe property damage or personal injury.

Prior to installation, check that the correct single-pipe vent parts were ordered and supplied.

The venting system must be installed in accordance with local building code requirements as well as national codes. For installations in Canada use CAN/CSA-B149.1 Natural Gas Installation Code or CAN/CSA-B149.2 Propane Installation Code as applicable; in the U.S. use the National Fuel Gas Code ANSI Z223.1 or NFPA Standard 54. Always use the latest edition of the applicable standard.

To ensure safe operation of the appliance, Viessmann recommends that the system be inspected once a year by a qualified service technician.

Every venting system must be planned and installed for optimum performance and safety. These Installation Instructions are designed to help you determine venting requirements and limitations with respect to installation. Please read and follow these instructions carefully.

It is the responsibility of the installer to contact local building and fire officials concerning any installation restrictions and/or inspection requirements that may apply. Permits may be required before commencement of the installation.

Vent System Manufacturers

The following PP(s) vent system manufacturers may be contacted for assistance in designing the appropriate venting system for Vitocrossal 300 CU3A boilers.

Listed manufacturers deliver PP(s) vents.

For Vitocrossal 300 CU3A (with boiler flue adaptor 110-100) the vent manufacturers developed special transition adaptors.

M&G / Duravent www.duravent.com	Centrotherm InnoFlue www.centrotherm.us.com
PolyFlue - Selkirk www.polyflue.com	ECCO Manufacturing www.eccomfg.com
Z-FLEX US Inc. NovaFlex Group www.novaflex.com	

The venting system components are tested and listed to ULC S636 or UL 1738 and are marked and labelled on each component.

IMPORTANT

DO NOT mix pipe, fittings, or joining methods from different vent system manufacturers. DO NOT use adhesives of any kind with this venting system.

The vent length requirements stated on pages 51 and 52 in this manual must be observed.

Flue gases are discharged via rigid PP(s) vent components to the outdoors. This vent system is constructed from flame-retardant plastic [polypropylene rated for a maximum temperature of 230°F (110°C)].

Side Wall Vent Termination

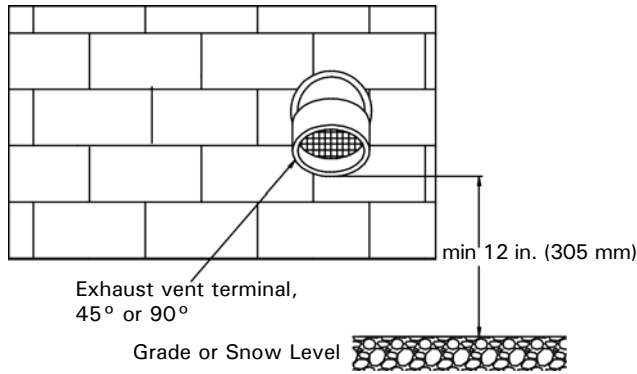

Side wall vent termination (front view)

IMPORTANT

For PP(s) systems, all exhaust vent and air intake piping and elbows exposed outside, must be UV resistant polypropylene (supplied by the vent manufacturer).

IMPORTANT

All PP(s) vent termination elbows, must be secured in place as specified by the manufacturer.

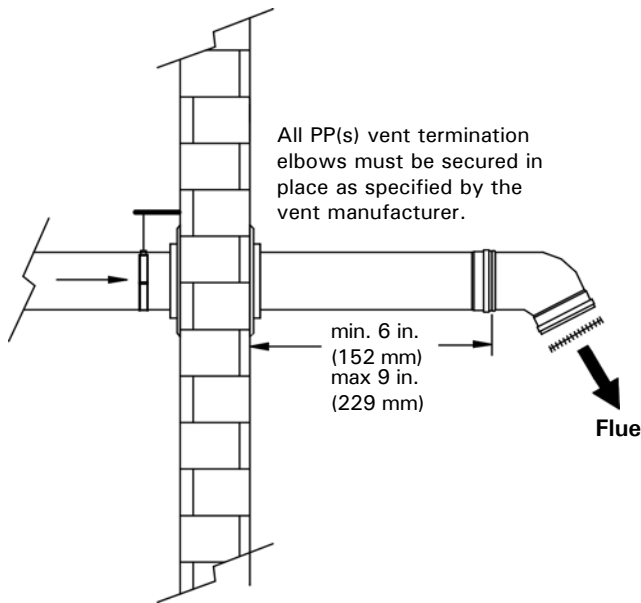

Side wall vent termination (side view)

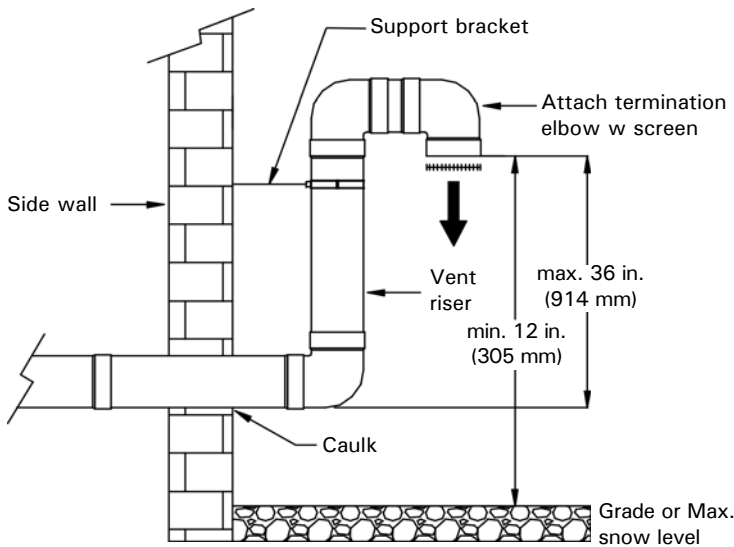

Installation of field supplied vent riser

Vent Length Requirements

Maximum vent pipe length - horizontal

All PP(s) vent material (if PP(s) used) must be ULC S636 or UL 1738 listed.

Size the exhaust vent pipe as specified in the table. This table lists the maximum allowable vent length in feet and meters of the exhaust piping. Vent diameter must not be reduced at any point in the installation.

IMPORTANT

First elbow not included in equivalent vent calculation. Always include vent termination length in calculations.

IMPORTANT

For PP(s) systems, all exhaust vent and air intake piping and elbows exposed outside, must be UV resistant polypropylene (supplied by the vent manufacturer).

Maximum allowable equivalent length - horizontal

Boiler Model	System Ø See note below	Max. combined equivalent vent length (a + b)
CU3A 26, 35	3 in. (80 mm)	198 ft. (60 m)
CU3A 45, 57	4 in. (110 or 100 mm)	198 ft. (60 m)

A 7% boiler input reduction @ 60 m for all sizes and all configurations.

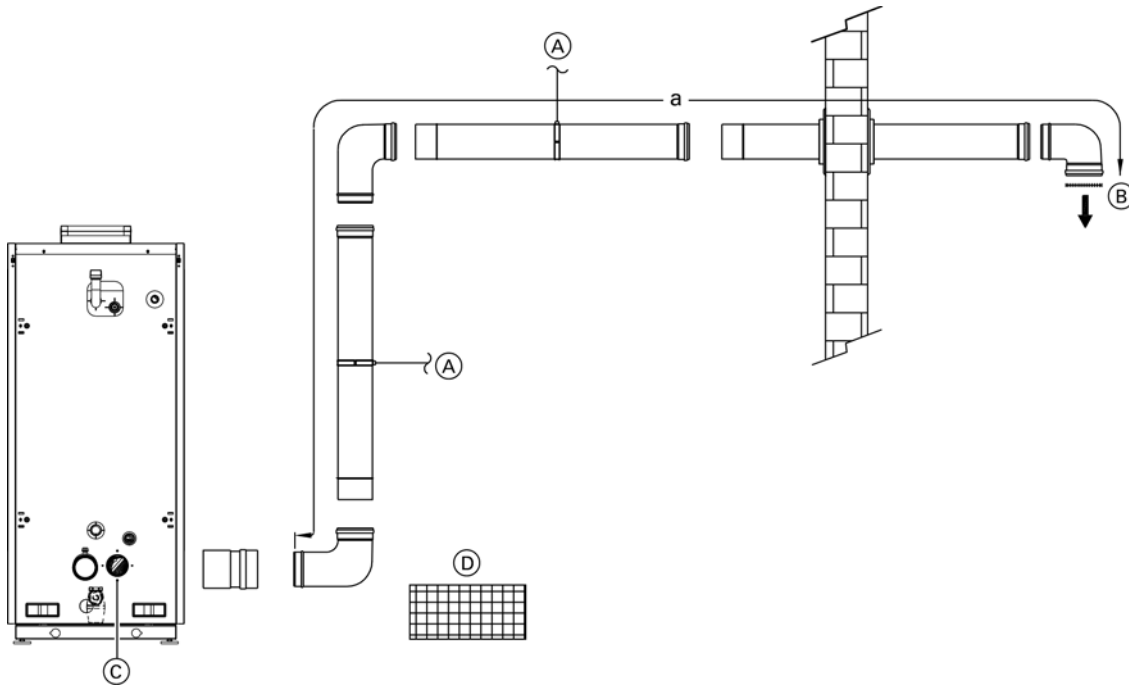

Legend

- (A) Support system
- (B) Exhaust vent termination
- (C) Combustion air intake
- (D) Combustion air opening (room)
- a Equivalent vent length (exhaust)

Vent Length Requirements *(continued)*

Maximum vent pipe length - vertical

All PP(s) vent material must be ULC S636 or UL 1738 listed. Size the exhaust vent pipe as specified in the table. This table lists the maximum allowable vent length in feet and meters of the exhaust piping. Vent diameter must not be reduced at any point in the installation.

Maximum allowable equivalent length - vertical

Boiler Model	System Ø See note below	Max. combined equivalent vent length (a + b)
CU3A 26, 35	3 in. (80 mm)	198 ft. (60 m)
CU3A 45, 57	4 in. (110 or 100 mm)	198 ft. (60 m)

A 7% boiler input reduction @ 60 m for all sizes and all configurations.

IMPORTANT

For PP(s) systems, all exhaust vent piping and elbows exposed outside, must be UV resistant polypropylene (supplied by the vent manufacturer).

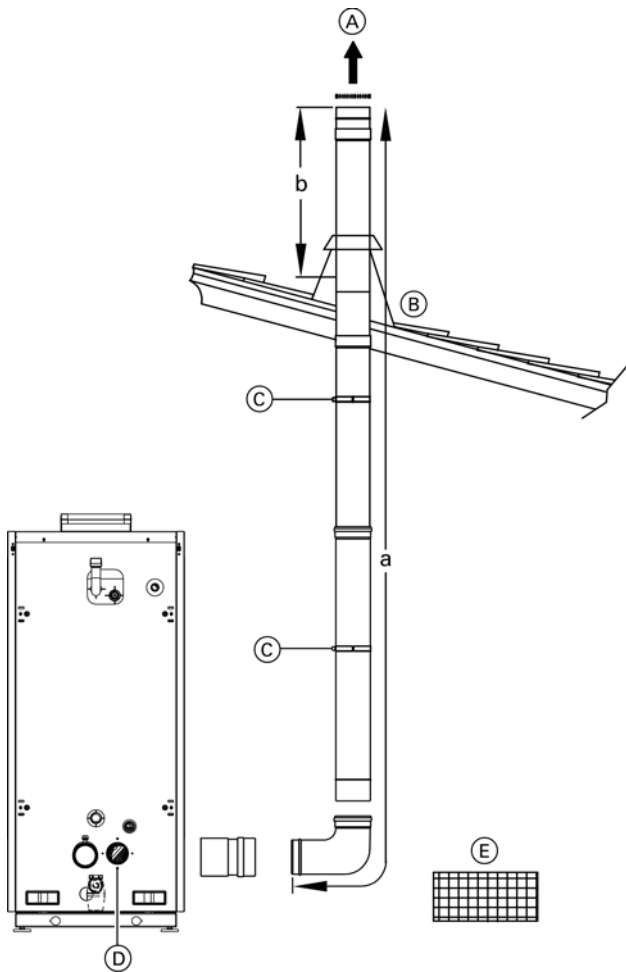

Legend

- (A) Exhaust (straight coupling) with screen
- (B) Flashings
- (C) Support system
- (D) Combustion air intake
- (E) Combustion air opening (room)
- a Equivalent length (exhaust)
- b min. 18 in. (457 mm)
max. 48 in. (1219 mm)

Component Installation Guide

General single-pipe vertical venting layout

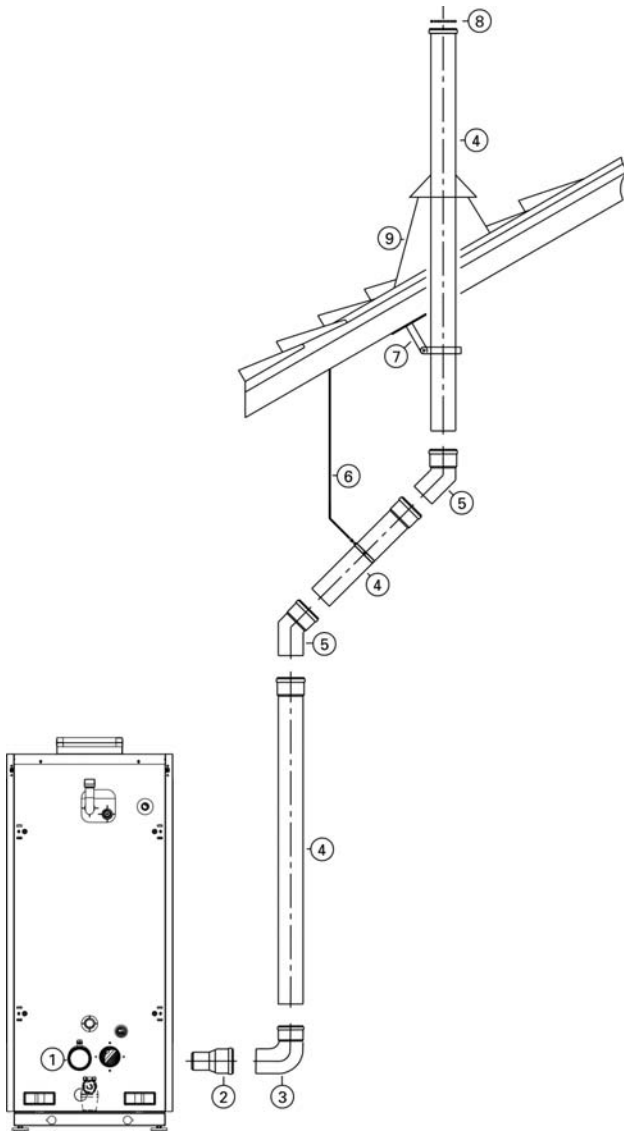

Legend

- ① Flue gasket outlet
- ② Vent pipe starter adaptor or PP(s) adaptor (110 mm to 100 mm when using M&G system with Vitocrossal 300 CU3A 45 or 57)
- ③ Elbow, 90°
- ④ Straight pipe *1
- ⑤ Elbow, 45°
- ⑥ Suspension band / hanger
- ⑦ Wall band
- ⑧ Vent termination coupling (with bird screen)
- ⑨ Flashing and storm collar

*1 Available in different lengths.

For more detailed information on component parts see product literature supplied by special venting manufacturer.

IMPORTANT

Ensure that the venting system is properly supported (see page 45).

Component Installation Guide *(continued)*

Single-pipe vent starter adaptor installation

Installing single-pipe vent adaptor for stainless steel, CPVC and PP(s) (if required)

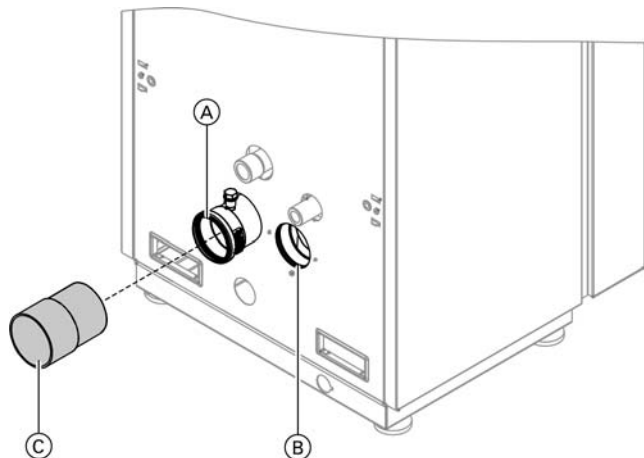

Legend

- (A) Boiler flue gas termination
- (B) Combustion air intake
- (C) CPVC, stainless steel adaptor or PP(s)

! WARNING

Prior to installation, ensure the specially designed single-pipe vent adaptor end is smooth and chamfered to prevent possible damage to the sealing gasket of the boiler vent pipe adaptor (coaxial). Failure to comply could result in leakage, potentially causing personal injury or death.

1. Apply small amount of water to end of single-pipe vent adaptor to ease insertion.
2. Slide special single-pipe vent adaptor (1) fully onto boiler vent pipe adaptor (2). Do not apply excessive force and/or bend single-pipe vent adaptor (1) when inserting. Force could damage gasket.

Ceiling/Roof opening

Cut an opening for the vent pipe.

Size opening at least 1 in. (25 mm) larger than vent pipe diameter (for combustible as well as non-combustible material).

Vent Termination Location Requirements

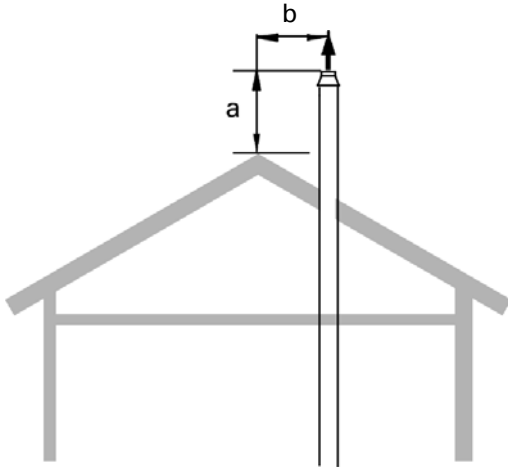

- For sloped roof applications with distance b less than 18 in. (450 mm)
 - a minimum 18 in. (450 mm)
 - b < 18 in. (450 mm)

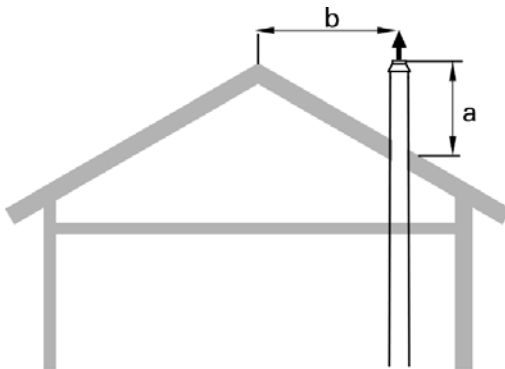

- For sloped roof applications with distance b greater than 18 in. (450 mm)
- For flat roof applications
 - a minimum 18 in. (450 mm)
 - b > 18 in. (450 mm)

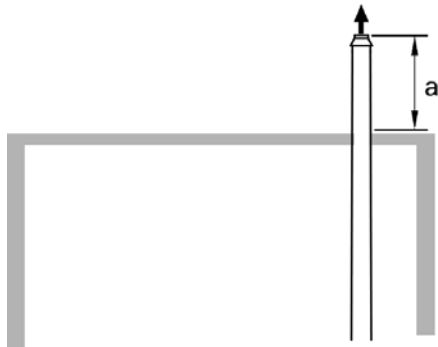

Vertical installations

The vent must be installed observing local regulations in addition to National Codes, CAN/CSA-B149.1 or 2 (for installations in Canada) or ANSI-Z223.1 or NFPA 54 (for installations in the U.S.A.).

! WARNING

Vent termination must be at least 12 in. (300 mm) above the anticipated snow level (consult your local building authorities or local weather office). Locate vent termination in such a way that it cannot be blocked by snow.

A vent used in a special venting system with positive vent pressure and passing through a roof shall extend at least 18 in. (450 mm) above the highest point where it passes through the roof and any other obstruction within a horizontal distance of 18 in. (450 mm).

The special vent system shall not be routed into, through, or within any other vent such as an existing masonry or factory-built chimney.

IMPORTANT

A masonry chimney flue may be used to route the venting system only if no other appliance is vented in the same flue.

Flashing and storm collar installation

Flashings and storm collars are field supplied. Flashings and storm collars suitable for Type B vent materials (or better) may be used.

To obtain flashings and storm collars, please contact your local vent material supplier. Follow the installation instructions supplied by the special venting manufacturer.

Vent Length Requirements

Equivalent vent length calculation example - vertical (stainless steel system)

Vitocrossal 300 CU3A

2 x 90° elbow.....	6 ft. (1.8 m)
2 x 45° elbow.....	4 ft. (1.2 m)
3 x vent pipe (0.5 m).....	4.9 ft. (1.5 m)
2 x vent pipe (1 m).....	6.6 ft. (2 m)
Total equivalent length.....	21.5 ft. 6.5 m

Above example will change as follows if using CPVC venting system (first 90° elbows are not included):

2 x 90° elbow.....	10 ft. (3.1 m)
2 x 45° elbow.....	6 ft. (1.8 m)
3 x vent pipe (0.5 m).....	4.9 ft. (1.5 m)
2 x vent pipe (1 m).....	6.6 ft. (2 m)
Total equivalent length.....	27.5 ft. (8.4 m)

Standard long sweep elbows

Material	90° elbow equivalent length ft. (m)	45° elbow equivalent length ft. (m)	87° elbow / inspection tee ft. (m)
Stainless steel	3 (0.91)	2 (0.61)	-
CPVC, ABS, PVC plastic pipe	5 (1.52)	3 (0.91)	-
PP(s)	-	1 (0.30)	1.6 (0.50)

Standard long sweep elbows (for CPVC pipe only)

Note: If standard sweep elbows are used the allowable vent lengths are reduced. One standard 90° elbow is equivalent to 8 ft. (2.4 m) of straight pipe. Long sweep elbows are recommended for use with venting system.

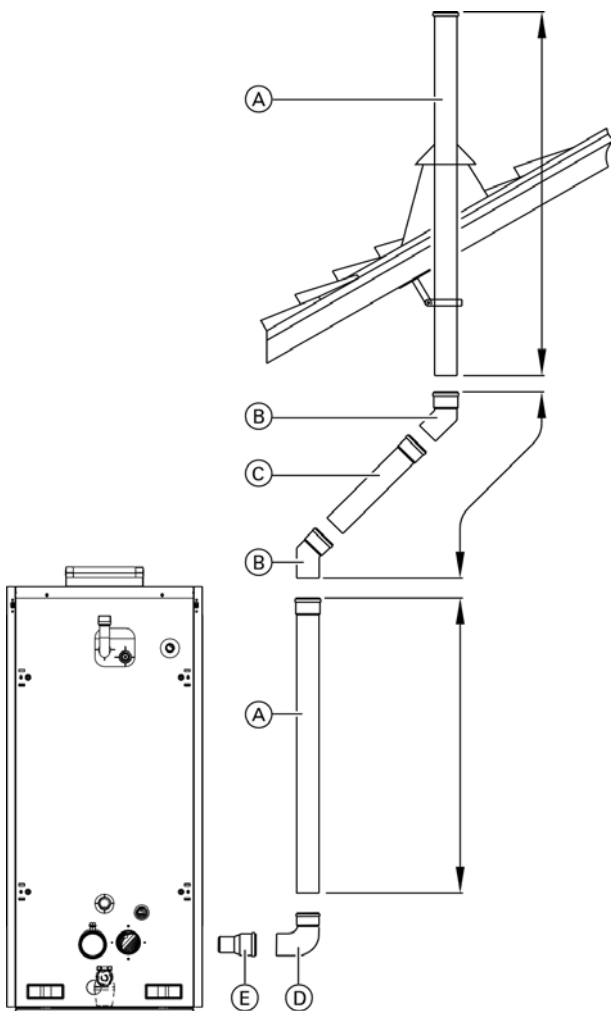

Legend

- Ⓐ Vent pipe 3.3 ft. (1 m)
- Ⓑ 45° elbow
- Ⓒ Vent pipe 1.6 ft. (0.5 m)
- Ⓓ 90° elbow
- Ⓔ Vent adaptor

Flue Vent Termination Requirements

Multiple boiler installations (vertical flue termination)

When terminating the vertical vent pipes of multiple Vitocrossal 300 CU3A boilers, a minimum clearance of 4 inches (100 mm) is required between the outside edges of each vent pipe.

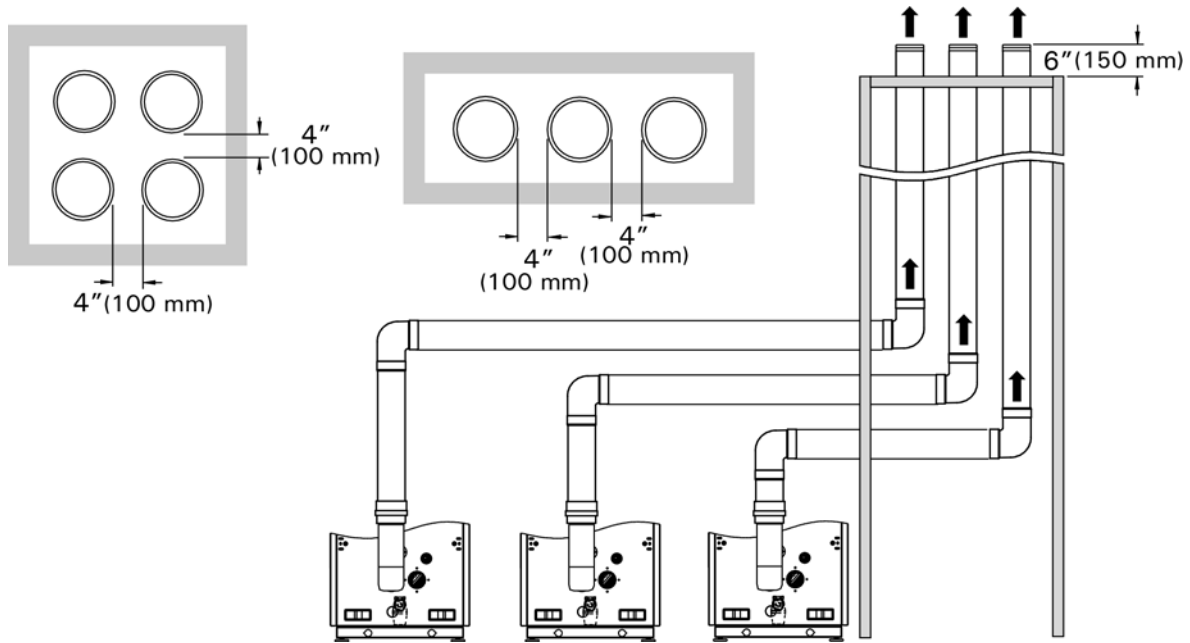

Multiple boiler installations (horizontal flue termination)

When terminating the horizontal vent pipes of multiple Vitocrossal 300 CU3A boilers, a minimum clearance of 12 inches (305 mm) is required between the outside edges of each vent pipe.

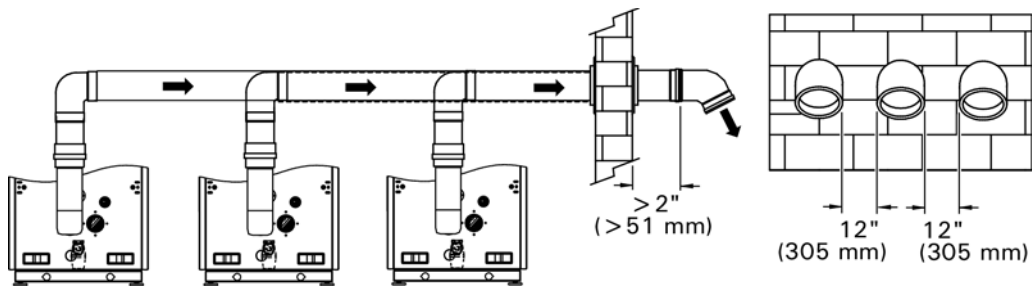

Installation of Support System - PP(s)

The venting system must be securely supported by a support system suitable for the weight and design of the materials employed. Contact your vent material supplier for more information specific to your installation.

Supports

The system support components must be ordered from the vent manufacturer. Follow the vent manufacturer's installation instructions for proper support spacing. The Vitocrossal 300 CU3A boiler vent terminals cannot support the weight of the venting components.

The following support types are available at your local vent material supplier...

- anchor plate
- wall support
- roof support
- floor support
- suspension band (hanger).

In addition to the support types listed above Viessmann offers mounting clips which can be used in conjunction with the above support types to support the weight of the venting system. Please contact Viessmann to order.

IMPORTANT

For PP(s) systems, all exhaust vent and air intake piping and elbows exposed outside, must be UV resistant polypropylene (supplied by the vent manufacturer).

Bracing

Contact your local vent material supplier for more information specific to your installation.

Braces are required to stabilize an installation. There are different types and their use and spacing vary.

The following types of braces are available at your local vent material supplier...

- wall band
- wall band extension
- guy wire band
- roof brace.

IMPORTANT

Ensure that the venting system is properly supported; the Vitocrossal 300 CU3A boiler is not designed to support the weight of the venting system.

General Flexible Pipe Installation Information

The Vitocrossal 300 CU3A boilers must be located in such a way that the vent length is as short as possible and that the vent can be routed as directly (and with as few bends) as possible.

See pages 66 and 67 for maximum vent lengths.

All products of combustion must be safely vented to the outdoors.

The Vitocrossal 300 CU3A boiler is not approved for common-venting applications. Do not common-vent with any other appliance. The Vitocrossal 300 CU3A boiler vents under positive pressure and is a Category IV boiler.

WARNING

Failure to ensure that all flue gases have been safely vented to the outdoors can cause property damage, severe personal injury, or loss of life. Flue gases may contain deadly carbon monoxide.

Viessmann recommends that the entire vent system be checked by a licensed professional heating contractor at least once each year following initial installation.

WARNING

Different manufacturers offer a number of different joint systems and adhesives. Do not mix pipes, fittings and/or joining methods from different manufacturers. Failure to comply could result in leakage, potentially causing personal injury or death.

Do not install vent pipe in a way that flue gases flow downwards. The direction of flue gas flow must be vertically upwards or horizontal with an upward slope.

Ensure there is no flue gas leakage into the area in which the boiler is installed.

Check proper location of gaskets in rigid PP(s) pipe collars. (Only use supplied parts with the polypropylene venting system).

Apply water to lubricate the joint ends of the vent pipe collar and if used, the air intake pipe collar.

Slide pipes into each other with a gentle twisting motion.

Check joints for leaks with the gas supply turned off and the fan running. Use a soapy solution to check for vent leaks.

Condensate must drain from the flue pipe to the boiler. Ensure a suitable gradient of at least 3° [approx. 2 in. per 3.3 ft. (50 mm per 1 m)].

No condensate trap is required in the vent pipe system.

If exhaust vent pipe system passes through an unheated space, such as an attic, it must be insulated. The insulation must have an R value sufficient to prevent freezing of the condensate. Armaflex insulation with ½ in. thickness and higher can be used.

The connection between the boiler and the base of the flexible pipe is made with rigid vent components (flexible pipe cannot be run directly to the boiler).

The flexible pipe can only be used in vertical installations.

Direct venting (two-pipe system) or single pipe (room air independent) is acceptable (refer to page 70 for combustion air requirements for room air dependent installations).

For direct venting applications the air intake pipe can be installed through the sidewall or vertical through the roof.

Any increaser used in the exhaust vent/air intake pipe must be installed in the vertical position.

The remaining space surrounding a chimney liner, gas vent, or special gas vent or plastic piping installed within a masonry, metal or factory-built flue shall not be used to supply combustion air (a separate combustion air pipe routed back to the boiler can be used in the remaining space if required).

Vent System Manufacturers

Use special venting system (UL/ULC listed for Category IV) for exhaust vent material of the Vitocrossal 300 CU3A boilers. Contact one of the following suppliers to order parts.

These manufacturers deliver PP(s) flexible vents in the required sizes.

M&G / Duravent www.duravent.com	Centrotherm InnoFlue www.centrotherm.us.com
PolyFlue - Selkirk www.polyflue.com	ECCO Manufacturing www.eccomfg.com
	Z-FLEX US Inc. NovaFlex Group www.novaflex.com

General Flexible Pipe Installation Information *(continued)*

Exhaust vent installation steps

! WARNING

Ensure that the entire venting system is protected from physical damages. A damaged venting system may cause unsafe conditions.

! WARNING

The venting system is approved for indoor installations only. Do not install the venting system outdoors.

The flexible pipes, rigid pipes and components are made from polypropylene material with excellent resistance to flue gas condensate formed in the exhaust vent of a gas-fired condensing heating boiler.

Every venting system must be properly planned and installed for optimum performance and safety. A flexible pipe installation always begins with an inspection of the existing masonry chimney (if being installed in a chimney as a liner). Inspect the masonry chimney for proper construction and compliance with applicable building codes.

A thorough cleaning of the chimney should be done prior to the installation of the chimney liner to ensure that it is free and clear of obstructions. Should an inspection reveal that an existing chimney is not safe for the intended application, it must be repaired or rebuilt to conform to NFPA 211 or any other applicable standards.

- Make sure you have available manpower in order to handle the flexible pipe.
- Determine the proposed location of the opening in the existing chimney. The slope of the connecting rigid flue pipe should be a minimum of 3° [equivalent to 2 in. per 3.3 ft. (50 mm per 1 m)].
- The length of the flexible vent system can be determined two ways: use a plumb line to measure the existing chimney length (add an extra 16 in. (40 cm) for each bend). The flexible vent system can be shortened by cutting with a saw or scissors within a groove. The correct length can also be determined after installing it in the existing chimney by cutting the flex pipe at the top of the chimney.
- Two lengths of the flexible vent system can be connected to each other with a flex pipe coupling (if required). See manufacturer's catalogue.
- Mount the spacer cross with a maximum distance of 6½ ft. (2 m) apart or as specified by the manufacturer.

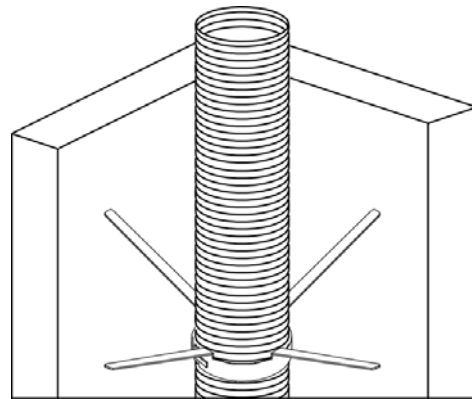

- Some installations may require the use of a rope connected to a pulling cone or directly to the bottom connector.
- With the adaptor and spacers connected, start installing the flex pipe from the top of the chimney and carefully feed the liner down through the middle. To prevent damage to the flex pipe additional manpower may be required to guide the flex pipe with a rope from the bottom of the chimney.

General Flexible Pipe Installation Information *(continued)*

Exhaust vent installation steps *(continued)*

- Once the bottom of the flex pipe and adaptor has reached the desired position, insert into the support elbow/support strip assembly.

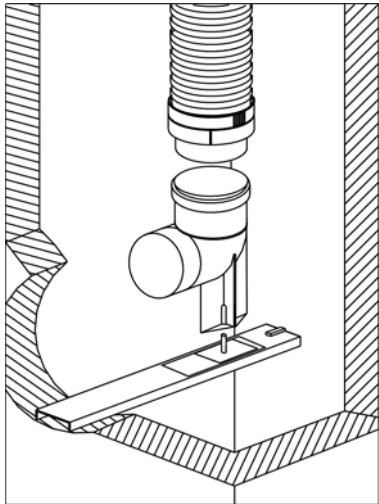

- Choose the required size and install the galvanized wall sleeve (cut to the width of the wall if required) and seal the space between the sleeve and the wall with mortar.

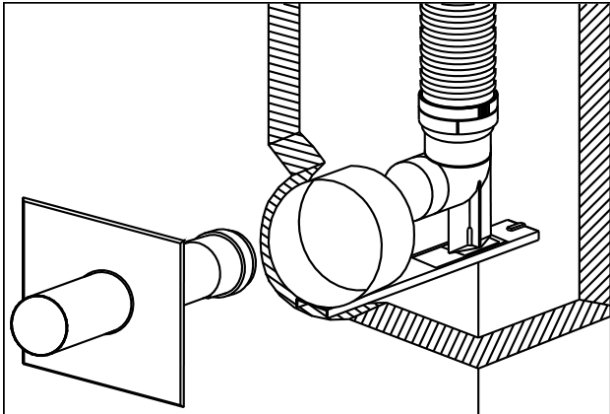

- Proceed with installing the rigid pipes and wall plate. Start from the chimney support elbow to the boiler adaptors (rigid pipes can be cut to the correct length if required).
- Seal the top wall of the chimney with a water resistant sealant.

IMPORTANT

When cutting rigid pipes to length, debur and clean pipes.

- *For flexible vent systems:*
In conjunction with these instructions, follow the installation instructions supplied by the special venting manufacturer.

Recommended venting practice

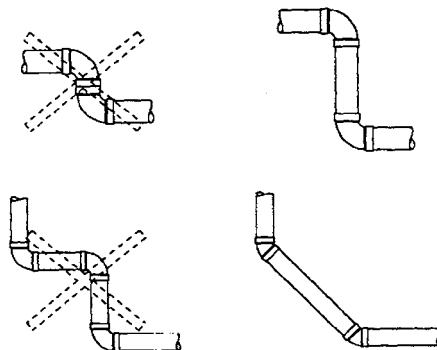

When installing a venting system the following recommended venting practices apply:

- Keep length and number of 90° elbows to a minimum.
- Try not to use back-to-back 90° elbows.
- Use 45° elbows where possible to minimize the number of 90° elbows in case redirection of flue gas is required.

Ceiling / roof opening

Cut an opening for the vent pipe. Size opening at least 1 in. (25 mm) larger than vent pipe diameter (for combustible as well as non-combustible material).

Combustion Air Supply

The Vitocrossal 300 CU3A boiler is suitable for vertical venting using rigid pipe and flexible pipe vent system material. The Vitocrossal 300 CU3A boilers are approved for both direct vent (sealed combustion), as well as direct exhaust (non-sealed combustion) operation in vertical arrangements. For non-sealed combustion vent systems (i.e. room-air dependent), see appropriate section under "Single Pipe Venting" starting on page 70 in this manual.

The boiler must be connected to a direct vent system in which all air for combustion is taken from the outside atmosphere and all combustion products are discharged safely to the outdoors.

The boiler must be vented and supplied with combustion air and exhaust vent as described in this section. Ensure the vent and combustion air supply comply with these instructions.

Inspect all finished exhaust vent/air intake piping to ensure:

- Vent/air intake pipe and fittings are of approved material.
- Acceptable size, length and number of elbows on combined vent/air intake system.
- Installation is in accordance with prevailing provisions of local codes.
- Installation complies with the requirements of these instructions, as well as the exhaust vent/air intake supplier's instructions.

The exhaust vent and combustion air intake system and terminations may be installed in one of the following type terminations (2-pipe system):

1. Vertical air intake and exhaust vent pipes.
2. Horizontal air intake pipe and vertical exhaust vent pipe.

CAUTION

Do not locate boiler in areas where high dust levels or high humidity levels are present.

CAUTION

If the boiler has been exposed to high dust levels, all burners and the heat exchanger must be cleaned prior to use.

CAUTION

Do not install boiler during construction involving drywall or heavy dust of any kind. Dust can accumulate in the burners and cause sooting. Install boiler after all heavy dust construction is completed.

CAUTION

If above criteria are not properly observed and boiler damage results, any warranty on the complete boiler and related components will be null and void.

* Typically when the boiler is used as a temporary heat source during the building construction phase.

Venting Options (Two-pipe System)

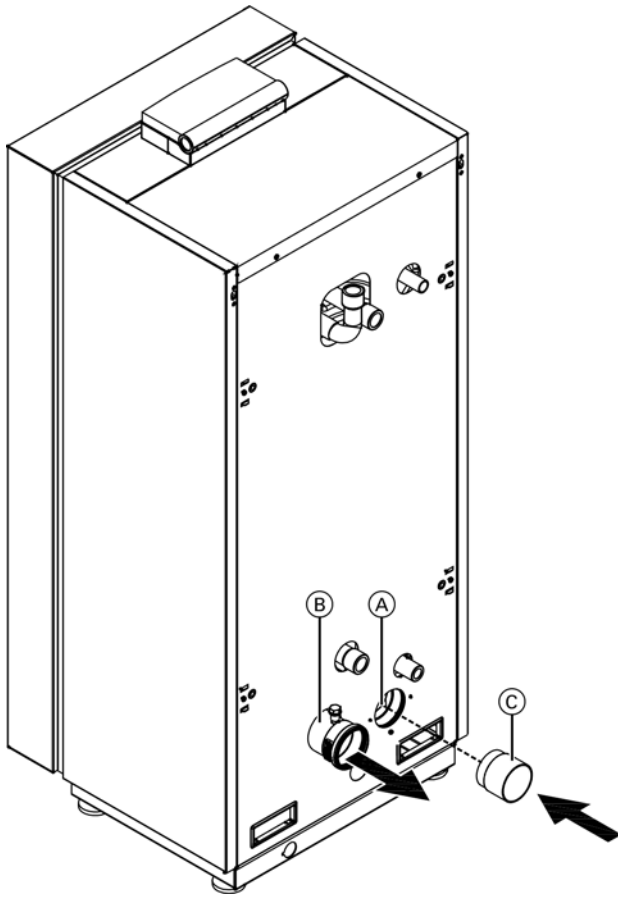

The two-pipe venting system draws combustion air (A) through a separate air intake pipe from the outdoors. Flue gases (B) are discharged to the outdoors via the single-pipe rigid-pipe and flexible vent system.

The two-pipe system is flexible in the selection of materials offered by different manufacturers and the location of the air intake termination.

Read the following exhaust vent/air intake requirements carefully before commencing with the installation.

Boiler	Flue Gas Exhaust Size	Intake
CU3A 26, 35	3 in. (80 mm)	3 in. (80 mm)
CU3A 45, 57	4 in. (110 mm)	3 in. (80 mm)

Legend

- (A) Combustion air intake
- (B) Boiler flue gas termination
- (C) Combustion air CPVC adaptor*

* An 80 mm to 3 in. combustion air CPVC adaptor is supplied with the boiler installation fittings.

Vent Requirements - Flexible Vent System / Connector Pipes

Additional requirements for UL/ULC-listed flexible vent system / connector pipe vent material

Exhaust vent/air intake connection to boiler

The vent/air intake connection to the Vitocrossal 300 CU3A boiler must be made according to the table below. The starter adaptors are intended for a slip fit and slide into the parallel adaptor or boiler adaptor with a gentle twisting motion.

For air intake pipe system, one wire mesh screens (bird screen) must be ordered from Viessmann. These parts are available in pre-cut diameters of 3 in. or 4 in.

Note: The Vitocrossal 300 CU3A boiler has passed the zero inches vent clearance to combustibles testing requirements dictated by the Harmonized Standard ANSI Z21.13. CSA 4.9 and therefore is listed for zero clearance to combustibles when vented with a single pipe special venting system.

	WARNING
The use of vent material other than listed flexible PP(s), positive pressure vent pipe and fittings can cause property damage, severe personal injury and/or loss of life.	

Required starter adaptors for CPVC air intake system / PPs flex vent system

Part	Boiler Model	Diameter	Supplier	Quantity
CPVC Starter Adaptor for Air Intake	CU3A 26, 35 CU3A 45, 57	3 in. (80 mm) 3 in. (80 mm)	Included with boiler	1
Combustion air increasers	CU3A 45, 57	3 in. to 4 in. (80 to 100 mm)	Field supplied	1
Wire Mesh Screen for Air Intake Termination	CU3A 26, 35	3 in. (80 mm)	Viessmann	1
Increaser Adaptor for Exhaust Pipe PP(s)	CU3A 26, 35	3 to 4 in. (80 to 100 or 110 mm)	Field supplied	1

Side Wall Air Intake Termination

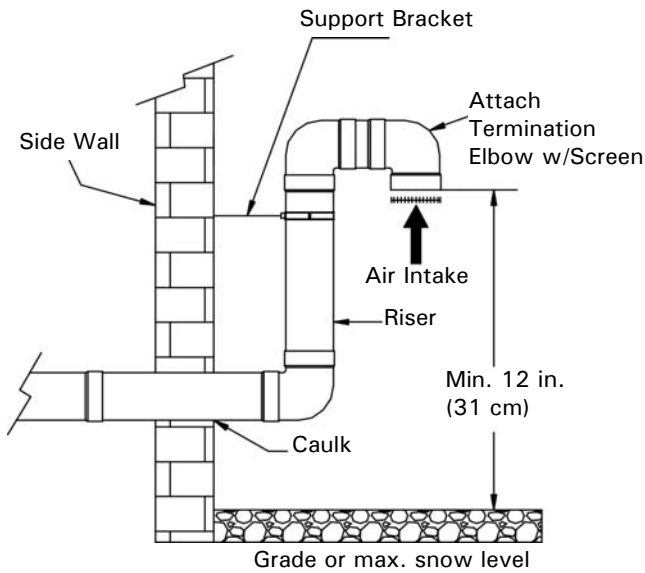

Installation of field fabricated air intake riser (side view)

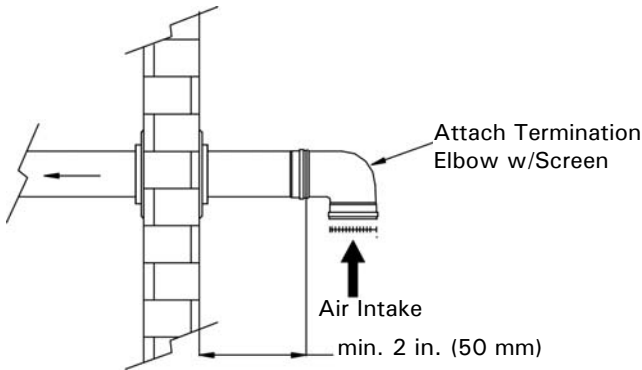

Side wall air intake termination (side view)

IMPORTANT

The air intake system must terminate so that proper clearances are maintained as cited in local codes or the latest edition of the "Natural Gas and Propane Installation Code" CAN/CSA-B149.1 (Canada), or the "National Fuel Gas Code" ANSI Z223.1 (NFPA 54) (U.S.A.). See pages 7 and 8.

! WARNING

Air intake must be at least 12 in. (300 mm) above the anticipated snow level (consult your local building authorities or local weather office). Locate vent termination in such a way that it cannot be blocked by snow.

Vent Length Requirements

Maximum vertical exhaust vent pipe length and vertical air intake pipe length

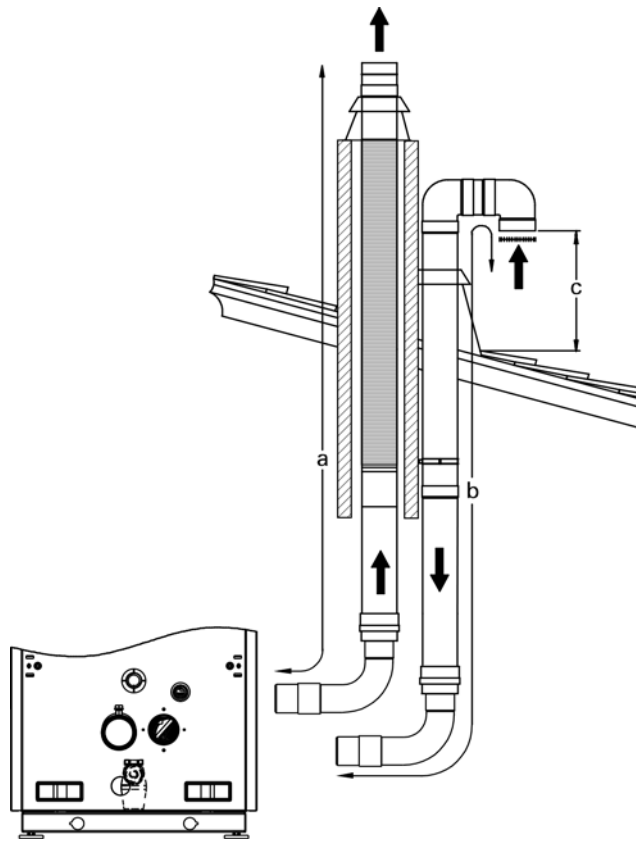

Legend

- a Equivalent length (exhaust)
- b Equivalent length (air intake)
- c 12 in. (305 mm) over max. local snow level
(check with your local weather office for details)

Maximum allowable equivalent length - vertical

Boiler Model	System Ø See note below	Max. combined equivalent vent length (a + b)
CU3A 26, 35	3 in. (80 mm)	149 ft. (45 m)
CU3A 45, 57	4 in. (110 or 100 mm)	149 ft. (45 m)

A 7% boiler input reduction @ 60 m for all sizes and all configurations.

Vent Length Requirements *(continued)*

Maximum exhaust vent pipe length vertical and air intake pipe length horizontal

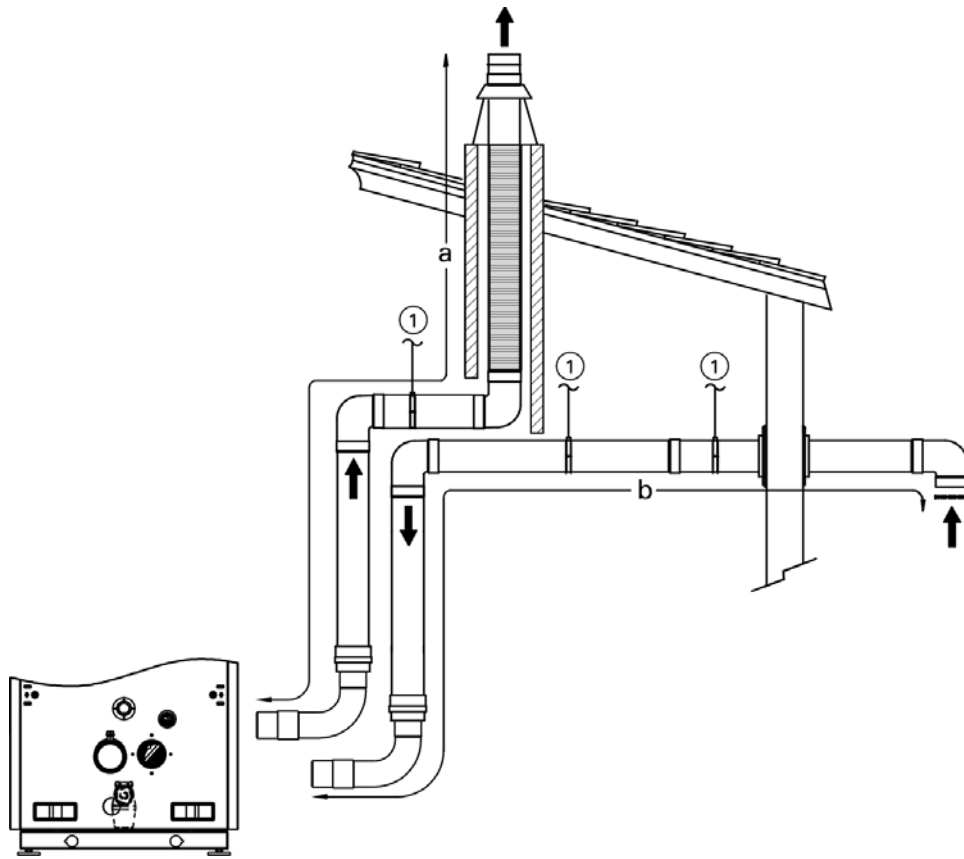

Legend

- a Equivalent length (exhaust)
- b Equivalent length (air intake)

Note: must be 12 in. (300 mm) over max. local snow level (check with your local weather office for details)

① Pipe support

Maximum allowable equivalent length - vertical exhaust / horizontal air intake (hybrid)

Boiler Model	System Ø See note below	Max. combined equivalent vent length (a + b)
CU3A 26, 35	3 in. (80 mm)	149 ft. (45 m)
CU3A 45, 57	4 in. (110 or 100 mm)	149 ft. (45 m)

A 7% boiler input reduction @ 60 m for all sizes and all configurations.

Vent Length Requirements *(continued)*

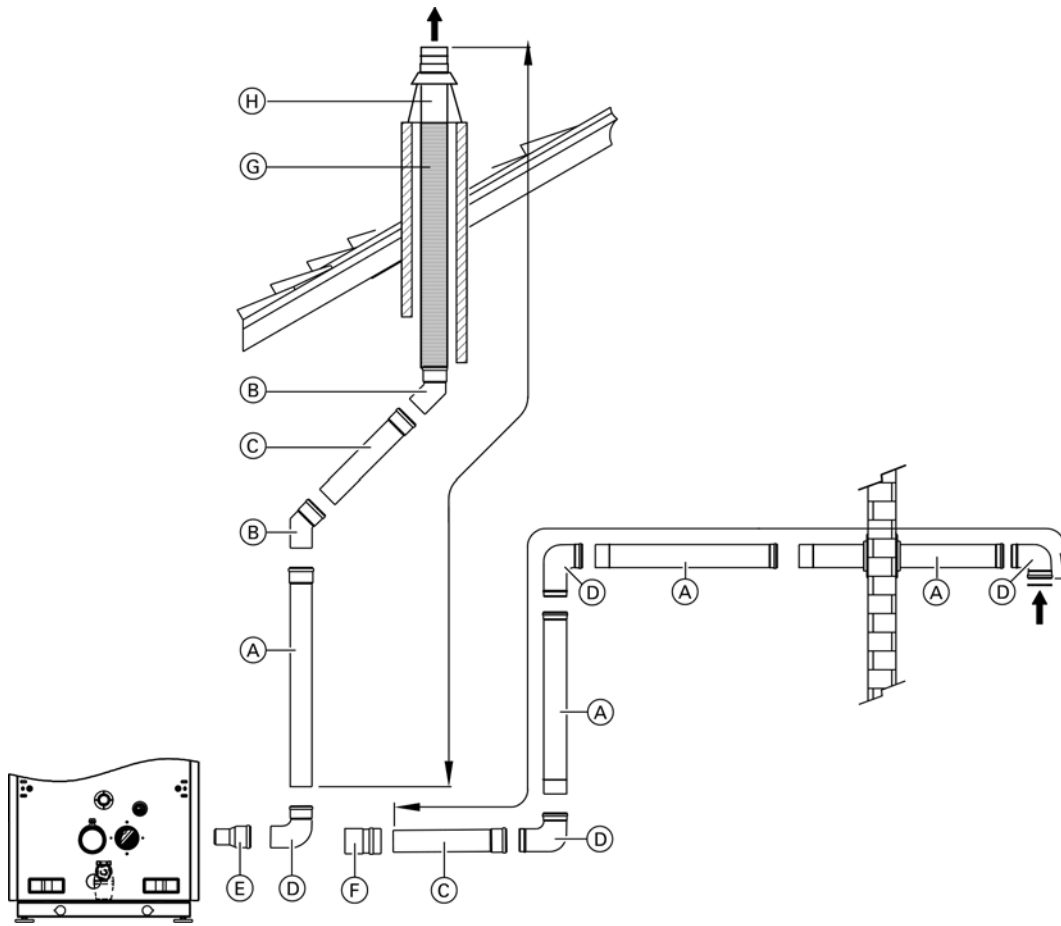

Legend

- (A) Vent pipe 3.3 ft. (1 m)
- (B) 45° elbow
- (C) Vent pipe 1.6 ft. (0.5 m)
- (D) 90° elbow
- (E) PP(s) adaptor (110 mm to 100 mm when using M&G system with Vitocrossal 300 CU3A 45 or 57)
- (F) Air intake adaptor
- (G) Flex pipe with adaptor set
- (H) Chimney cap with termination pipe

Note: If standard sweep elbows are used the allowable vent lengths are reduced.
 One standard 90° elbow is equivalent to 8 ft. (2.4 m) of straight pipe.

Standard long sweep elbows

Material	90° elbow equivalent length	45° elbow equivalent length	87° elbow / 87° inspection tee
CPVC plastic pipe	5 ft. (1.52 m)	3 ft. (0.91 m)	---
PP(s) flexible pipe system	---	1 ft. (0.3 m)	1.6 ft. (0.5 m)

IMPORTANT

Always include vent termination length in calculations.

Equivalent vent length calculation example (Vitocrossal 300 CU3A 26/35 systems diameter 3 in.)

Maximum allowable equivalent length is 149 ft. (45 m)

- 2 x 90° stainless steel elbow.....6 ft. (1.83 m)
- 2 x 45° stainless steel elbow.....4 ft. (1.22 m)

Air intake pipe

- 1 x 90° plastic (ABS/CPVC/PVC) elbow.....5 ft. (1.52 m)
- 1 x 45° plastic (ABS/CPVC/PVC) elbow.....3 ft. (0.91 m)
- Exhaust vent pipe.....10 ft. (3.05 m)
- Air intake pipe.....10 ft. (3.05 m)
- Combined total equivalent vent length
- (a + b).....38 ft. (11.58 m)

Combustion Air Supply

The boiler used in this application requires fresh air for safe operation and must be installed in a mechanical room where there are provisions for adequate combustion and ventilation air.

There are no provisions available on the Vitocrossal 300 CU3A boiler to interlock it with an external combustion air blower.

The Vitocrossal 300 CU3A boiler is suitable for vertical venting using flexible venting system material. The Vitocrossal 300 CU3A boilers are approved for direct exhaust (non-sealed combustion) operation in vertical arrangements only.

Provisions for combustion and ventilation air must be made in accordance with CAN/CSA-B149.1 or .2 Natural Gas Installation Codes (for installations in Canada) or in accordance with sections for Combustion and Ventilation Air, of the National Fuel Gas Code, ANSI Z223.1 or applicable provisions of local codes (for installations in the U.S.A.) Always use the latest edition of the applicable standard.

Follow local codes to properly isolate the vent pipe when passing through floors, ceilings and roof.

Whenever possible, install boiler near an outside wall so that it is easy to duct fresh air directly to the boiler area. Refer to national codes for duct sizing. Round ducts may be used.

The boiler must be vented and supplied with combustion air and exhaust vents as described in this section. Ensure the vent and combustion air supply comply with these instructions.

WARNING

Failure to provide an adequate supply of fresh combustion air can cause poisonous flue gases to enter living space, which can cause severe personal injury or loss of life.

The boiler location should never be under negative pressure. Exhaust fans, attic fans, or dryer fans may cause air to be exhausted at a rate higher than the air can enter the structure for safe combustion. Corrective action must be taken to ensure enough air is available. Never cover the boiler or store debris or other materials near the boiler, or in any way block the flow of adequate fresh combustion air to the boiler.

If boiler is installed in a confined space (a space with a volume of less than 50 cubic feet per 1000 Btu/h of gas input for all fuel burning equipment) or building layout is unusually tight, adequate air for combustion must be provided by two openings: one located about 6 in. (152 mm) below the ceiling, the other about 6 in. (152 mm) above the floor. When communicating directly with the outside, each opening must have a minimum free area of one square inch per 2000 Btu/h of gas input. When all combustion air is provided by openings in doors, etc. to adjoining spaces having adequate infiltration, each opening must have a minimum free area of one square inch per 1000 Btu/h of gas input, but not less than 100 in².

You must know the free area of louvers used to cover up the combustion and ventilation openings in closet installations. If you do not know the free area, assume 20% for wood louvers and 60 - 75% free area for metal louvers. When using louvers, the openings have to be made larger. For example, a free 14 in. x 6 in. (356 mm x 152 mm) opening becomes a 14 in. x 10 in. (356 mm x 254 mm) opening for a grill containing metal louvers.

CAUTION

Do not store chemicals containing chlorine or other corrosive materials near the boiler, such as bleach, cleaning solvents, detergents, acids, hair spray, spray cans, paint thinners, paint, water softener salt, perchloroethylene, or carbon tetra chloride.

Inspect all finished exhaust vent/air intake piping to ensure:

- Vent pipe and fittings are of approved material.
- Acceptable size, length and number of elbows on combined vent pipe system.
- Installation is in accordance with prevailing provisions of local codes.
- Installation complies with the requirements of these instructions, as well as the exhaust vent supplier's instructions.

The exhaust vent system and terminations may be installed in the vertical exhaust vent type of termination.

CAUTION

Exposure to corrosive materials can cause heat exchanger corrosion and failure.

CAUTION

Do not locate boiler in areas where high dust levels or high humidity levels are present.

CAUTION*

Do not install boiler during construction involving drywall or heavy dust of any kind. Dust can accumulate in the burners and cause sooting. Install boiler after all heavy dust construction is completed.

* Typically when the boiler is used as a temporary heat source during the building construction phase.

CAUTION

If the boiler has been exposed to high dust levels, all burners and the heat exchanger must be cleaned prior to use.

Note: If above criteria are not properly observed and boiler damage results, any warranty on the complete boiler and related components will be null and void.

Vent Length Requirements

Maximum vertical exhaust vent pipe length

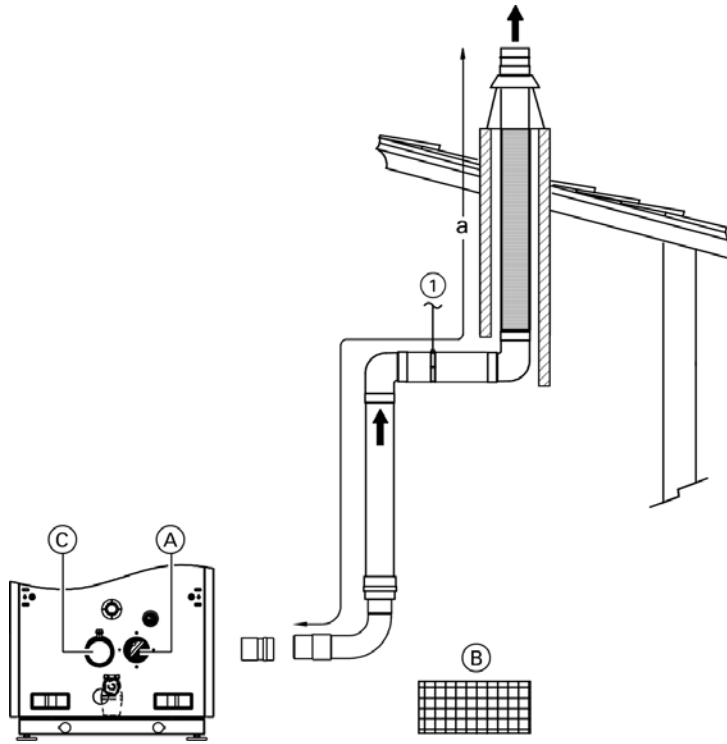

Legend

- (A) Combustion air intake
- (B) Combustion air opening (room)
- (C) Boiler flue termination
- a Equivalent vent length (exhaust)
- (1) Pipe support

Maximum allowable equivalent length - vertical

Boiler Model	System Ø See note below	Max. combined equivalent vent length (a + b)
CU3A 26, 35	3 in. (80 mm)	149 ft. (45 m)
CU3A 45, 57	4 in. (110 or 100 mm)	149 ft. (45 m)

A 7% boiler input reduction @ 45 m for all sizes and all configurations.

General Component Parts of the Flex Venting System

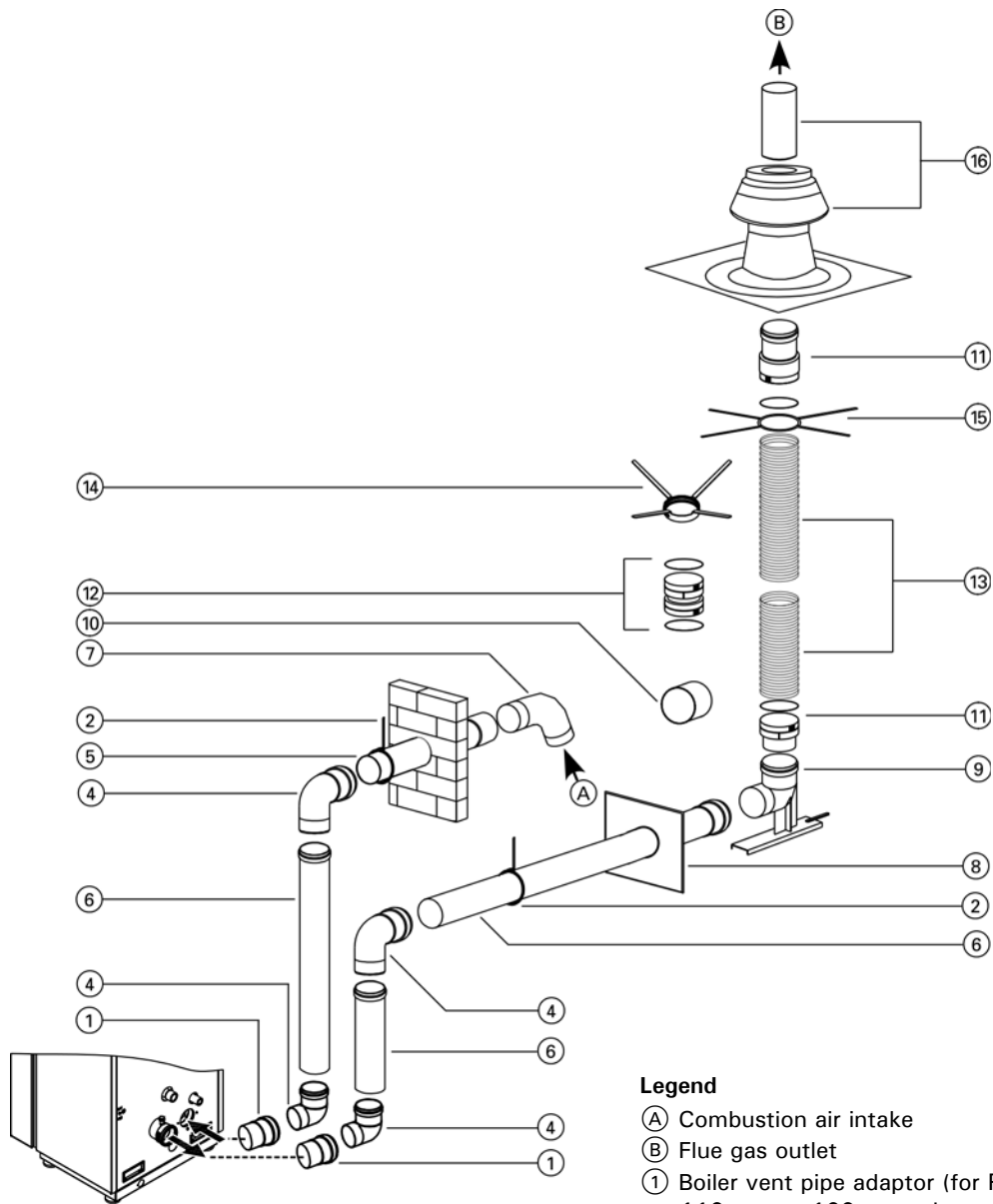

Legend

- (A) Combustion air intake
- (B) Flue gas outlet
- (1) Boiler vent pipe adaptor (for PP(s) adaptor 110 mm to 100 mm when using M&G system with Vitocrossal 300 CU3A 45 or 57)
- (2) Pipe support (mounting clip)
- (3) Adaptors
- (4) 90° elbows
- (5) Combustion air intake vent material
- (6) Straight pipe
- (7) Vent termination
- (8) Wall plate
- (9) 90° support elbow
- (10) Wall sleeve
- (11) Adaptor set
- (12) Coupling
- (13) Flex pipe
- (14) Spacer cross
- (15) Support cross
- (16) Chimney cap with termination pipe

Printed on environmentally friendly
(recycled and recyclable) paper.



Technical information subject to change without notice.

Viessmann Manufacturing Company Inc.
750 McMurray Road
Waterloo, Ontario • N2V 2G5 • Canada
TechInfo Line 1-888-484-8643
1-800-387-7373 • Fax (519) 885-0887
www.viessmann.ca • info@viessmann.ca

Viessmann Manufacturing Company (U.S.) Inc.
45 Access Road
Warwick, Rhode Island • 02886 • USA
TechInfo Line 1-888-484-8643
1-800-288-0667 • Fax (401) 732-0590
www.viessmann-us.com • info@viessmann-us.com