

Installation Instructions

for use by heating contractor



- Vitodens 100-W B1HA/B1KA Combi
- Vitodens 100-W B1HE/B1KE Combi
- Vitodens 200-W B2HA/B2HB
- Vitodens 200-W B2HE
- Vitodens 222-F B2TB
(with preinstalled coaxial vent pipe adaptor)



Rigid and Flex Pipe Venting Systems



Product may not be exactly as shown

IMPORTANT

Read and save these instructions for future reference.

Safety, Installation and Warranty Requirements

Please ensure that these instructions are read and understood before commencing installation. Failure to comply with the instructions listed below and details printed in this manual can cause product/property damage, severe personal injury, and/or loss of life. Ensure all requirements below are understood and fulfilled (including detailed information found in manual subsections).

■ Licensed professional heating contractor

The installation, adjustment, service and maintenance of this equipment must be performed by a licensed professional heating contractor.

► Please see section entitled "Important Regulatory and Installation Requirements" in the Installation Instructions.



■ Product documentation

Read all applicable documentation before commencing installation. Store documentation near boiler in a readily accessible location for reference in the future by service personnel.

► For a listing of applicable literature, please see section entitled "Important Regulatory and Safety Requirements" in the Installation Instructions.



■ Carbon monoxide

Improper installation, adjustment, service and/or maintenance can cause flue products to flow into living space. Flue products contain poisonous carbon monoxide gas.

► For information pertaining to the proper installation, adjustment, service and maintenance of this equipment to avoid formation of carbon monoxide, please read these Installation Instructions carefully.



■ Equipment venting

Never operate boiler without an installed venting system. An improper venting system can cause carbon monoxide poisoning.

■ Warranty

Information contained in this and related product documentation must be read and followed. Failure to do so renders the warranty null and void.



■ Advice to owner

Once the installation work is complete, the heating contractor must familiarize the system operator/ultimate owner with all equipment, as well as safety precautions/requirements, shutdown procedure, and the need for professional service annually before the heating season begins.

! WARNING

Installers must follow local regulations with respect to installation of carbon monoxide detectors. Follow manufacturer's maintenance schedule boiler.

How these Installation Instructions are Structured....

These Instructions cover the following venting systems for the Vitodens 100-W, 200-W and 222-F boilers. Refer to the section applicable to your application for pertinent installation information.

Before proceeding with the installation, please read sections entitled Safety and General Information. These sections are applicable to all venting systems listed and must be read before commencing the installation.

Information specific to...

- Side Wall Vent Installations (Coaxial) is found in the Side Wall Vent Installation Section starting on page 16.
- Vertical Vent Installations (Coaxial) is found in the Vertical Vent Installation Section starting on page 24
- Direct Vent Installations (Two-pipe System) is found in the Direct Vent Section starting on page 31.
- Single Pipe Vent Installations (Room Air Dependent) is found in the Single Pipe Venting Section starting on page 59.
- Flexible vent installations on page 83.

Page

Safety

Safety, Installation and Warranty Requirements.....2
How these Installation Instructions are Structured.....2
Important Regulatory and Installation Requirements.....7
 Operation with direct vent using coaxial vent system....8
 Vent termination location requirements
 (for installations in Canada).....9
 Vent termination location requirements
 (for installations in the U.S.A.).....9
 For coaxial venting systems only.....10
 For flex venting systems only.....10
Common Venting.....10
About These Installation Instructions.....11

General Information

General Rigid Venting Installation.....12
 Installation steps (outline).....12
 Vent system manufacturers.....12
 Recommended venting practice.....13
Leak Test (for coaxial venting systems only).....13
 Vitodens boiler vent adaptors14
Vent Termination Location Requirements.....15
 Vertical installations.....15
 Flashing and storm collar installation.....15

**Side Wall Vent Installation
(Coaxial)**

Side Wall Venting Layouts (Coaxial).....16
Wall Mounted Multiple Boiler Horizontal Vent Terminations..19
Manifold Mounted Multiple Boiler Horizontal Vent Terminations..19
Coaxial Vent Termination.....20
Venting Length.....22

**Vertical Vent Installation
(Coaxial)**

Vertical Venting Layouts (Coaxial).....24
 Layout of vertical vent system with accessories.....24
 General installation examples.....25
Component Installation Guide.....26
 Coaxial vent termination installation.....26
 Wall opening information.....26
 Vertical vent termination installation.....26
 Multiple boiler installations (vertical coaxial termination
 with multiple boilers).....26
Installation of Support System.....27
 Supports.....27
 Bracing.....27
Vent Length Requirements.....28
 Maximum vent length.....28
 Maximum vent length with increasers.....29
 Maximum vent length for vertical installations.....29
 Minimum vent length.....29
 Equivalent vent length calculation example.....30

	Page
Direct Venting (Two-pipe System)	
General Installation Information	31
Installation steps (outline).....	31
Exhaust and combustion air piping material.....	31
Approved combustion air intake materials.....	32
Exhaust Vent/Air Intake Requirements	33
Combustion air supply.....	33
General requirements.....	34
Vent Requirements - Stainless Steel	35
Additional requirements for stainless steel vent pipe material.....	35
Component Parts of the Venting System - Stainless Steel	40
Vent Requirements - CPVC	41
Additional requirements for CPVC vent pipe material.....	41
Exhaust Vent/Air Intake Connection To Boiler.....	41
Requirements for Rigid PP(s) Vent Pipe Material	42
Vent system manufacturers.....	42
Vent and Air Intake Pipe Starter Adaptors - PP(s)	43
Side Wall Vent Termination - Stainless Steel, CPVC or PP(s)	46
Vent Length Requirements	47
Maximum vent/air intake pipe length - horizontal.....	47
Maximum vent/air intake pipe length - horizontal/vertical (hybrid system).....	51
Standard Elbows	52
Equivalent vent length calculation example.....	53
Component Parts of the PP(s) Venting System	55
Vertical pipe system.....	55
For Direct Vent 2 Pipe Venting Systems.....	56
Horizontal pipe system.....	58

**Single Pipe Venting
(Room Air Dependent)**

	Page
Vent Requirements	59
Combustion air supply.....	59
General Installation Information	60
Installation steps (outline).....	61
Exhaust vent pipe material.....	61
Support system.....	62
Additional requirements for stainless steel vent pipe material.....	62
Exhaust vent pipe connection to boiler.....	62
Exhaust vent termination options.....	63
Other exhaust vent termination options (horizontal installation).....	64
Requirements for Rigid PP(s) Vent Pipe Mater	69
Vent system manufacturers.....	69
Boiler Connections with PP(s) System	70
Side Wall Vent Termination	71
Vent Length Requirements	72
Maximum vent pipe length - horizontal.....	72
Maximum vent pipe length - vertical.....	74
Component Installation Guide	76
General single-pipe vertical venting layout.....	76
Single-pipe vent starter adaptor installation.....	77
Ceiling/Roof opening.....	77
Single-pipe venting system.....	78
Equivalent vent length calculation example-vertical....	79
Single-pipe vent termination installation.....	80
Vent Termination Spacing	81
Multiple boiler installations (vertical termination with multiple boilers).....	81
Multiple boiler installations (horizontal termination with multiple boilers).....	81
Installation of Support System - PP(s)	82
Supports.....	82
Bracing.....	82

General Information

General Flexible Pipe Installation.....83
 Exhaust vent installation steps.....84
 Recommended venting practice.....84
 Ceiling / roof opening.....84
 Approved materials for two-pipe system.....85

Exhaust Vent Requirements.....86
 Vent system suppliers.....86

**Direct Venting
(Two-pipe System)**

Combustion Air Supply.....87
Starter Adaptor.....88
Parallel Adaptor.....90
Vent Requirements-Flex Vent System/Connector Pipes...91
 Additional requirements for lexible vent system /
 connector pipe vent material.....91
 Exhaust vent/air intake connection to boiler.....91
Side Wall Air Intake Termination.....92
Vent Length Requirements.....93
 Maximum exhaust vent pipe length vertical and
 air intake pipe length vertical.....93
 Maximum allowable equivalent length.....94
 Maximum exhaust vent pipe length vertical and
 air intake pipe length horizontal.....95
 Maximum allowable equivalent length.....96
 Standard elbows (for CPVC / PVC / ABS
 pipes air intake use only).....96
 Standard elbows.....96

**Single Pipe Venting
(Room Air Dependent)**

Combustion Air Supply.....97
Adaptors.....98
Vent Length Requirements.....99
 Maximum allowable vent pipe length - vertical.....99
Component Installation Guide.....100
 Single pipe vent pipe starter adaptor installation
 (if required).....100

Componentry

General Component Parts of the Flex Venting System.101
Two Pipe Options (Direct Vent).....102
Single Pipe Options (Room Air Dependent).....103
Two Pipe Options (Direct Vent).....104
Single Pipe Options (Room Air Dependent).....105
Two Pipe Options (Direct Vent).....106
Single Pipe Options (Room Air Dependent).....107
Two Pipe Options (Direct Vent).....108
Single Pipe Options (Room Air Dependent).....109
Coaxial Vent System Options (Direct Vent).....110

Important Regulatory and Installation Requirements

For installations on the Commonwealth of Massachusetts, the following modifications to NFPA-54 chapter 10 apply:

Excerpt from 248 CMR 5-08:

- 2(a) For all side-wall horizontally vented gas fueled equipment installed in every dwelling, building or structure used in whole or in part for residential purposes, including those owned or operated by the Commonwealth and where the side-wall exhaust vent termination is less than (7) feet above finished grade in the area of the venting, including but not limited to decks and porches, the following requirements shall be satisfied:
1. **INSTALLATION OF CARBON MONOXIDE DETECTORS.** At the time of installation of the side-wall horizontal vented gas fueled equipment, the installing plumber or gas fitter shall observe that a hard wired carbon monoxide detector with an alarm and battery back-up is installed on the floor level where the gas equipment is to be installed. In addition, the installing plumber or gas fitter shall observe that a battery operated or hard wired carbon monoxide detector with an alarm is installed on each additional level of the dwelling, building or structure served by the side-wall horizontal vented gas fueled equipment. It shall be the responsibility of the property owner to secure the services of qualified licensed professional for the installation of hard-wired carbon monoxide detectors.
 - a. In the event that the side-wall horizontally vented gas fueled equipment is installed in a crawl space or an attic, the hard-wired carbon monoxide detector with alarm and battery back-up may be installed on the next adjacent floor level.
 - b. In the event that the requirements of this subdivision can not be met at the time of completion of installation, the owner shall have a period of thirty (30) days to comply with the above requirements; provided, however, that during said thirty (30) day period, a battery operated carbon monoxide detector with an alarm shall be installed.
 2. **APPROVED CARBON MONOXIDE DETECTORS.** Each carbon monoxide detector as required in accordance with the above provisions shall comply with NFPA 720 and be ANSI/UL 2034 listed and IAS certified.
 3. **SIGNAGE.** A metal or plastic identification plate shall be permanently mounted to the exterior of the building at a minimum height of eight (8) feet above grade directly in line with the exhaust vent terminal for the horizontally vented gas fueled heating appliance or equipment. The sign shall read, in print size no less than one-half (1/2) inch in size, "GAS VENT DIRECTLY BELOW. KEEP CLEAR OF ALL OBSTRUCTIONS".
 4. **INSPECTION.** The state or local gas inspector of the side-wall horizontally vented gas fueled equipment shall not approve the installation unless, upon inspection, the inspector observes carbon monoxide detectors and signage installed in accordance with the provisions of 248 CMR 5.08(2)(a) 1 through 4.
- (b) **EXEMPTIONS:** The following equipment is exempt from 248 CMR 5.08(2)(a) 1 through 4:
1. The equipment listed in Chapter 10 entitled "Equipment Not Required To Be Vented" in the most current edition of NFPA 54 as adopted by the Board; and
 2. Product Approved side-wall horizontally vented gas fueled equipment installed in a room or structure separate from the dwelling, building or structure used in whole or in part for residential purposes.

Important Regulatory and Installation Requirements *(continued)*

IMPORTANT

When replacing parts, use original Viessmann or Viessmann approved replacement parts.

The venting system must be installed by a licensed professional heating contractor familiar with the operation and maintenance of heating appliances and venting. Before installing this product, ensure that the complete installation literature has been read. Failure to follow proper installation procedures as stated in these instructions, including vent pitch and proper appliance connections, may violate local, provincial/state, or national codes and cause unsafe conditions which may lead to severe property damage or personal injury.

The venting system must be installed in accordance with local building code requirements as well as national codes. For installations in Canada use CAN/CSA-B149.1 Natural Gas Installation Code or CAN/CSA-B149.2 Propane Installation Code as applicable; in the U.S. use the National Fuel Gas Code ANSI Z223.1 or NFPA Standard 54. Always use the latest edition of the applicable standard.

To ensure safe operation of the boiler, Viessmann recommends that the system be inspected once a year by a qualified service technician.

Every venting system must be planned and installed for optimum performance and safety. These Installation Instructions are designed to help you determine venting requirements and limitations with respect to installation. Please read and follow these instructions carefully.

It is the responsibility of the installer to contact local building and fire officials concerning any installation restrictions and/or inspection requirements that may apply. Permits may be required before commencement of the installation.

The vent termination for side wall air intake installations should be located on a wall that is least affected by prevailing winds. High winds may affect boiler operation and/or degrade the exterior finish of the wall. They may also cause recirculation of the boiler's own flue products. Recirculation of flue products can result in poor combustion and inlet condensation problems. If wind is a problem, steps must be taken to shield the vent termination from high winds, such as building a fence or planting shrubs. Ensure that the total equivalent vent length is not exceeded.

Operation with direct vent using coaxial vent system

IMPORTANT

Side wall vent installations must include Viessmann protective screen.

Because of its sealed combustion chamber, the Vitodens gas-fired condensing boiler is suitable for operation with balanced flue.

The Vitodens boiler, flue gas adaptor and parallel adaptor (if used) are approved together under CSA 4.9. ANSI Z21.13 Standard.

IMPORTANT

DO NOT mix pipe, fittings, or joining methods from different vent system manufacturers.
DO NOT use adhesives of any kind with this venting system.

The vent length requirements stated in this manual (starting on page 47 for direct vent installations and page 72 for single pipe vent installations) must be observed.

The combustion air is supplied and the flue gas discharged via a coaxial double pipe. Combustion air is fed through the circular gap between the outer aluminum air intake pipe and the vent pipe. Flue gases are discharged via an inner pipe constructed from flame-retardant plastic (polypropylene rated for a maximum temperature of 230°F (110°C)).

Not all inspection authorities require a leak test of the vent-air intake system in conjunction with the wall-mounted gas-fired boiler during system start-up. In cases where the leak test is not required, Viessmann recommends that the heating contractor perform a simplified leak test when starting up the system. For this purpose, it is sufficient to measure the CO₂ concentration in the combustion air of the circular gap of the coaxial vent-air intake pipe. The vent pipe is considered sufficiently leak-proof if the CO₂ concentration in the combustion air is no higher than 0.2% and the O₂ concentration no lower than 20.6%.

If higher CO₂ or lower O₂ values are measured, the flue gas system must be checked for leaks.

The coaxial venting material can be extended (without exceeding the maximum equivalent length) beyond the outside wall of the structure, provided that the coaxial venting material is installed in an enclosed, insulated and waterproof chase that is acceptable for outdoor installation. The vent termination location must comply with the instructions and codes stated in this manual.

IMPORTANT

Potential gaps between the vent-air intake and surrounding construction which may cause air, rain or flue gases to leak into the wall or the building, must be sealed with approved sealant/caulking to prevent leakage of any kind.

Important Regulatory and Installation Requirements *(continued)*

Vent termination location requirements (for installation in Canada)

The vent must be installed observing local regulations in addition to National Codes, CAN/CSA-B149.1 or 2.

A vent must NOT terminate...

1...directly above a paved sidewalk or paved driveway which is located between two single-family dwellings and serves both dwellings.

2...less than 7 ft. (2.13 m) above a paved sidewalk or a paved driveway located on public property.

3...within 6 ft. (1.83) m of a mechanical air supply inlet*1 to any building (dryer vents, non-sealed combustion furnace and hot water heater vents are considered to be mechanical air inlets).

*1 *Including heat recovery units.*

4...above a meter/regulator assembly within 3 ft. (0.9 m) horizontally of the vertical centerline of the regulator vent outlet and to a maximum vertical distance of 15 ft. (4.5 m).

5...within 3 ft. (0.9 m) of any gas service regulator vent outlet.

6...less than 1 ft. (0.3 m) above grade level or anticipated snow level (consult local building authorities or local weather office). Locate the vent termination in such a way that it cannot be blocked by snow.

7...within the following distances of a window or door which can be opened in any building, any non-mechanical air supply inlet to any building or the combustion air inlet of any other appliance:

- 1 ft. (0.3 m) for inputs up to and including 100 000 Btu/h (30 kW).
- 3 ft. (0.9 m) for input exceeding 100 000 Btu/h (30 kW).

Vent termination location requirements (for installation in the U.S.A.)

The vent must be installed observing local regulations in addition to National Codes, ANSI-Z223.1 or NFPA 54.

A vent must NOT terminate...

1...less than 7 ft. (2.13 m) above a paved sidewalk or a paved driveway located on public property.

2...above a meter/regulator assembly within 3 ft. (0.9 m) horizontally of the vertical centerline of the regulator vent outlet and to a maximum vertical distance of 15 ft. (4.5 m).
.....within 3 ft. (0.9 m) of any gas service regulator vent outlet.

3...at least 3 ft. (0.9 m) above any forced air inlet located within 10 ft. (3 m).

4...less than 1 ft. (0.3 m) above grade level or anticipated snow level (consult local building authorities or local weather office). Locate the vent termination in such a way that it cannot be blocked by snow.

5...within 1 ft. (0.3 m) of a window or door which can be opened in any building, any non-mechanical air supply inlet to any building or the combustion inlet of any other appliance.

8...underneath a veranda, porch or deck, unless:

- the veranda, porch, or deck is fully open on a minimum of two sides beneath the floor, and
- the distance between the top of the vent termination and the underside of the veranda, porch, or deck is greater than 1 ft. (0.3 m).

9...in areas where condensation may cause problems, such as above planters, patios, or adjacent to windows where flue gases may cause fogging.

10...within 3 ft. (0.9 m) to the property line (advisable, not mandatory; please check with local building authorities and municipal bylaws).

11...at a location where ice formation on the ground can present a hazard.

12...so that the flue gases are directed toward brickwork, soffits, siding, or other construction, in such a manner that may cause damage from heat or condensate from the flue gases.

13...where discharging hot flue gases may cause property damage or personal injury.

14...within 3 ft. (0.9 m) from an inside corner of outside walls.

6...in areas where condensation may cause problems, such as above planters, patios, or adjacent to windows where flue gases may cause fogging.

7...within 3 ft. (0.9 m) to the property line (advisable, not mandatory; please check with local building authorities and municipal bylaws).

8...at a location where ice formation on the ground can present a hazard.

9...so that the flue gases are directed toward brickwork, siding, or other construction, in such a manner that may cause damage from heat or condensate from the flue gases.

10...where discharging hot flue gases may cause property damage or personal injury.

11...within 3 ft. (0.9 m) from an inside corner of outside walls.

Important Regulatory and Installation Requirements *(continued)*

Clearance to combustibles

Top	Front	Rear	Left	Right	Vent pipe
0 in. (mm)	0 in. (mm)	0 in. (mm)	0 in. (mm)	0 in. (mm)	0 in. (mm)

Vent-air intake system must be properly installed and sealed. The venting system may be concealed in a chase. If venting system passes through an unheated space, such as an attic, it must be insulated. The insulation must have an R value sufficient to prevent freezing of the condensate. Armaflex insulation with ½ in. thickness and higher can be used.

For coaxial venting systems only

Minimum and maximum wall thickness through which the horizontal vent-air intake termination may be installed:

Minimum: 1 in. (25.4 mm)

Maximum: 19.6 in. (497.8 mm)

For flex venting systems only

Flexible vent pipe may be installed as a liner within a masonry, metal or factory-built chimney.

WARNING

The Vitodens 100-W and 222-F boilers are NOT approved for common-venting applications. Do not attempt to common-vent the Vitodens boilers with any other boiler.

WARNING

Failure to ensure that all flue gases have been safely vented to the outdoors can cause property damage, severe personal injury, or loss of life. Flue gases may contain deadly carbon monoxide.

CAUTION

Under certain climatic conditions some building materials may be affected by flue products expelled in close proximity to unprotected surfaces. Sealing or shielding of the exposed surfaces with a corrosion resistant material (e.g. aluminum sheeting) may be required to prevent staining or deterioration. The protective material should be attached and sealed (if necessary) to the building before attaching the vent termination. It is strongly recommended to install the vent termination on the leeward side of the building.

Common Venting

IMPORTANT

Some Vitodens 200-W boilers are approved for common venting applications. Refer to the chart below to determine which Vitodens are approved for common venting.

All Vitodens boilers vent under positive pressure and are Category IV boilers.



For more information on common venting refer to the Vitodens Common Venting Installation Instructions.

Vitodens Boilers Approved for Common Venting	Vitodens Boilers NOT Approved for Common Venting
B2HA 45, 60, 80, 88,100, 112, 150, 285, 311, 352, 399, 530	B2HA 19, 28, 35
B2HB 45, 57, 160, 199	B2HB 19, 26, 35, 68, 94, 125
B2HE 85, 120, 150, 199	B2TB 19, 35, 68,125
	B1HA 26, 35, 94, 125
	B1KA 35, 125
	B1HE 85, 120, 150, 199
	B1KE 120, 199

About These Installation Instructions



Take note of all symbols and notations intended to draw attention to potential hazards or important product information. These include "WARNING", "CAUTION", and "IMPORTANT". See below.



WARNING

Indicates an imminently hazardous situation which, if not avoided, could result in death, serious injury or substantial product/property damage.

▶ Warnings draw your attention to the presence of potential hazards or important product information.



CAUTION

Indicates an imminently hazardous situation which, if not avoided, may result in minor injury or product/property damage.

▶ Cautions draw your attention to the presence of potential hazards or important product information.

IMPORTANT

▶ Helpful hints for installation, operation or maintenance which pertain to the product.



▶ This symbol indicates that additional, pertinent information is to be found.



▶ This symbol indicates that other instructions must be referenced.

General Rigid Venting Installation

Installation steps (outline)

 **WARNING**

Ensure that the entire venting system is protected from physical damages. A damaged venting system may cause unsafe conditions.

 **WARNING**

The venting system is approved for indoor installations only. Do not install the venting system outdoors.

IMPORTANT

Proximity to damp and salty marine environments directly influences the service life of the boiler's exposed metallic surfaces, such as the casing and fan housing. In such areas, higher concentration levels of chlorides from sea spray, coupled with relative humidity, can lead to degradation of the exposed metallic surfaces mentioned above. Therefore, it is imperative that boilers installed in such environments not be installed using direct vent systems which draw outdoor air for combustion. Such boilers must be installed using room air dependent vent systems; i.e. using room air for combustion. The indoor air will have a much lower relative humidity and, hence, the corrosion will be minimized.

- Route vent pipe as directly as possible and with as few bends as possible to the boiler.
- Check proper location of gaskets in rigid PP(s) pipe collars. (Only use supplied parts with the polypropylene venting system).
Apply water (or lubricant supplied with the venting system) to lubricate the joint ends of the vent pipe collar and if used, the air intake pipe collar.
- Slide pipes into each other with a gentle twisting motion.
- Condensate must drain from the flue pipe to the boiler. Ensure a suitable gradient of at least 2-3° based on the vent manufacturer's system design [example: for a 3° system approx. 2 in. per 3.3 ft. (50 mm per 1 m) on any horizontal venting components].
- Use a hacksaw or sheet metal snips (for stainless steel) to cut pipes to length (if necessary). Use a file to smooth rough edges. Pipe must be round and not bent into an oval shape.

IMPORTANT

When cutting pipes to length, debur and clean pipes.

Vent system manufacturers

The following Coaxial and PP(s) vent system manufacturers may be contacted for assistance in designing the appropriate venting system for Vitodens boilers.

All manufacturers deliver PP(s) rigid and flexible vents in the required sizes.

M&G / Duravent www.duravent.com	Centrotherm InnoFlue www.centrotherm.us.com
*PolyFlue - Selkirk www.polyflue.com	ECCO Manufacturing www.eccomfg.com
Z-FLEX US Inc. NovaFlex Group www.novaflex.com	Cox Geelen www.coxgeelen.com

* requires double pipe system with coaxial termination only.

For Vitodens B2HA 80, 88, 100, 112, 150, 285, 311, 352, 399, 530, (with boiler flue adaptor 110 - 150) the vent manufacturers developed special transition adaptors.

General Rigid Venting Installation *(continued)*

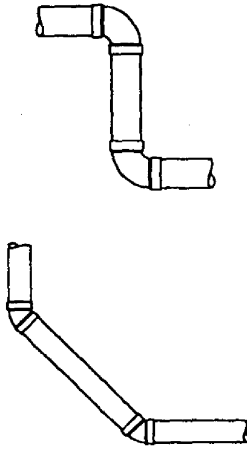

Recommended venting practice

When installing a venting system the following recommended venting practices apply:

- Keep length and number of 90° elbows to a minimum.
- Try not to use back-to-back 90° elbows.
- Use 45° elbows where possible to minimize the number of 90° elbows in case redirection of flue gas is required.
- The special vent system shall not be routed into, through, or within any other vent such as an existing masonry or factory-built chimney.

Exception:

A masonry chimney flue may be used to route the venting system only if no other boiler is vented in the same flue.

IMPORTANT

Route the flue gas connection to be free of load and torque stresses. We recommend fitting an on-site support immediately downstream of the boiler flue connection.

Leak Test (for coaxial venting systems only)

Viessmann recommends that the heating contractor perform a simplified leak test during boiler start-up. For this purpose it is sufficient to measure the CO₂ concentration of the combustion air in the annular gap of the air intake pipe.

The vent pipe is considered sufficiently leak-proof if a CO₂ concentration in the combustion air no higher than 0.2% or an O₂ concentration no lower than 20.6% is measured relative to a starting O₂ concentration of 20.9%.

If higher CO₂ values or lower O₂ values are measured, inspect the venting system thoroughly.

Continuous short cycling of the boiler can indicate a leaking venting system.

Note: The vent pipe adaptor comes with two measurement ports, one for combustion air intake measurement and one for flue gas measurement.

General Rigid Venting Installation *(continued)*

Vitodens boilers vent adaptors

This system draws combustion air from the boiler room. Room/Combustion air enters the boiler at the boiler vent pipe adaptor through an annular air gap.

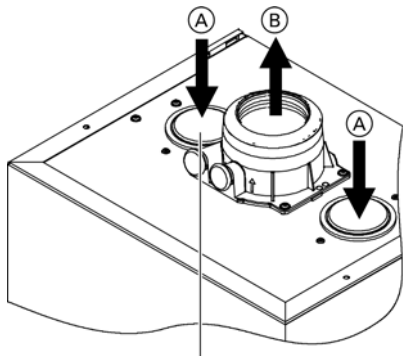

When utilizing the combustion air inlet seal (A) for Vitodens 100, B1HA and B1KA, 200 B2HA/B and 222 B2TB series boilers, remove the inlet seal (A), tear out center section and install the remaining rubber seal back into the air inlet opening shown below.

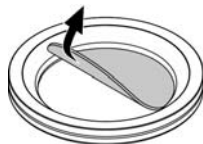

If using annular air gap, remove and discard air inlet cover or use optional opening to the left or right.

Boiler	Flue Gas Exhaust Size
B1HA 26, 35, 94, 125 B1KA 35, 125 B2HA 19, 28, 35, B2HB 19, 26, 35, 68, 94, 125 B2TB 19, 35, 68, 125	2 in. (60 mm)
B2HA 45, 60 B2HB 45, 57, 160, 199 B1HE 85, 120, 150, 199 B1KE 120, 199 B2HE 85, 120, 150, 199	3 in. (80 mm)
B2HA 80, 88, 100, 112, 150, 285, 311, 352, 399, 530	4 ³ / ₈ in. (110 mm)

The two-pipe venting system draws combustion air (A) through a separate air intake pipe from the outdoors. Flue gases (B) are discharged to the outdoors via the single-pipe rigid-pipe and flexible vent system.

The two-pipe system is flexible in the selection of materials offered by different manufacturers and the location of the air intake termination.

Read the following exhaust vent/air intake requirements carefully before commencing with the installation.

Boiler models Vitodens 200-W, B2HA 45, 60, 80, 88, 100, 112, 150, 285, 311, 352, 399, 530
B2HB 45, 57, 160, 199

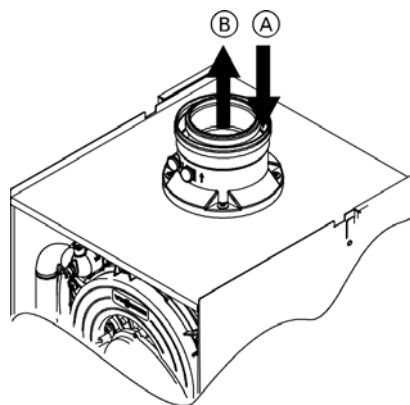

Legend

- (A) Combustion air
- (B) Flue gas

Boiler models Vitodens 100-W B1HA 26, 35, 94, 125 (without left side combustion air) and B1KA 35, 125 (without left side combustion air) and 100 B1HE 85, 120, 150, 199, Vitodens 100 B1KE 120, 199 and Vitodens 200 B2HE 85, 120, 150, 199.

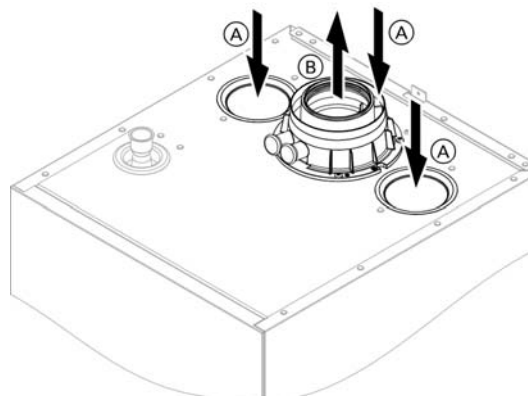

Legend

- (A) Combustion air
- (B) Flue gas

Vent Termination Location Requirements

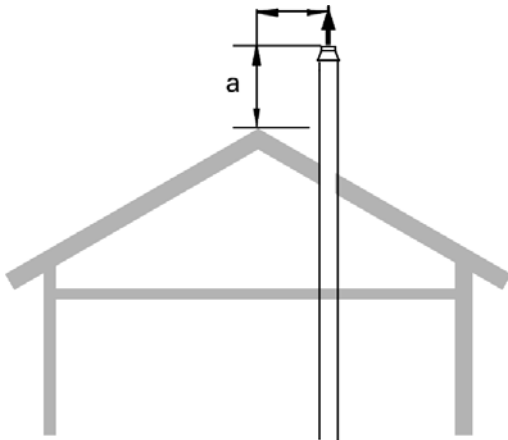

■ For sloped roof applications with distance b less than 18 in. (450 mm)

- a minimum 18 in. (450 mm)
- b < 18 in. (450 mm)

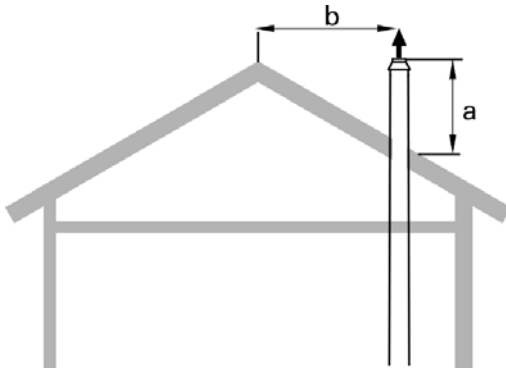

■ For sloped roof applications with distance b greater than 18 in. (450 mm)

■ For flat roof applications

- a minimum 18 in. (450 mm)
- b > 18 in. (450 mm)

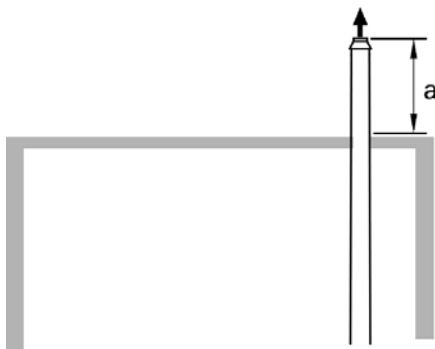

Vertical installations

The vent must be installed observing local regulations in addition to National Codes, CAN/CSA-B149.1 or 2 (for installations in Canada) or ANSI-Z223.1 or NFPA 54 (for installations in the U.S.A.).

! WARNING

Vent termination must be at least 12 in. (300 mm) above the anticipated snow level (consult your local building authorities or local weather office). Locate vent termination in such a way that it cannot be blocked by snow.

A vent used in a special venting system with positive vent pressure and passing through a roof shall extend at least 18 in. (450 mm) above the highest point where it passes through the roof and any other obstruction within a horizontal distance of 18 in. (450 mm).

The special vent system shall not be routed into, through, or within any other vent such as an existing masonry or factory-built chimney.

IMPORTANT

A masonry chimney flue may be used to route the venting system only if no other boiler is vented in the same flue.

Flashing and storm collar installation

Flashings and storm collars are field supplied. Flashings and storm collars suitable for Type B vent materials (or better) may be used.

To obtain flashings and storm collars, please contact your local vent material supplier. Follow the installation instructions supplied by the special venting manufacturer.

Follow local codes to properly isolate the exhaust vent pipe when passing through floors, ceiling and roof.

Always check the marking on the pipe to make sure you are using the correct material.

Side Wall Venting Layouts (Coaxial)

Layout with basic coaxial vent componentry

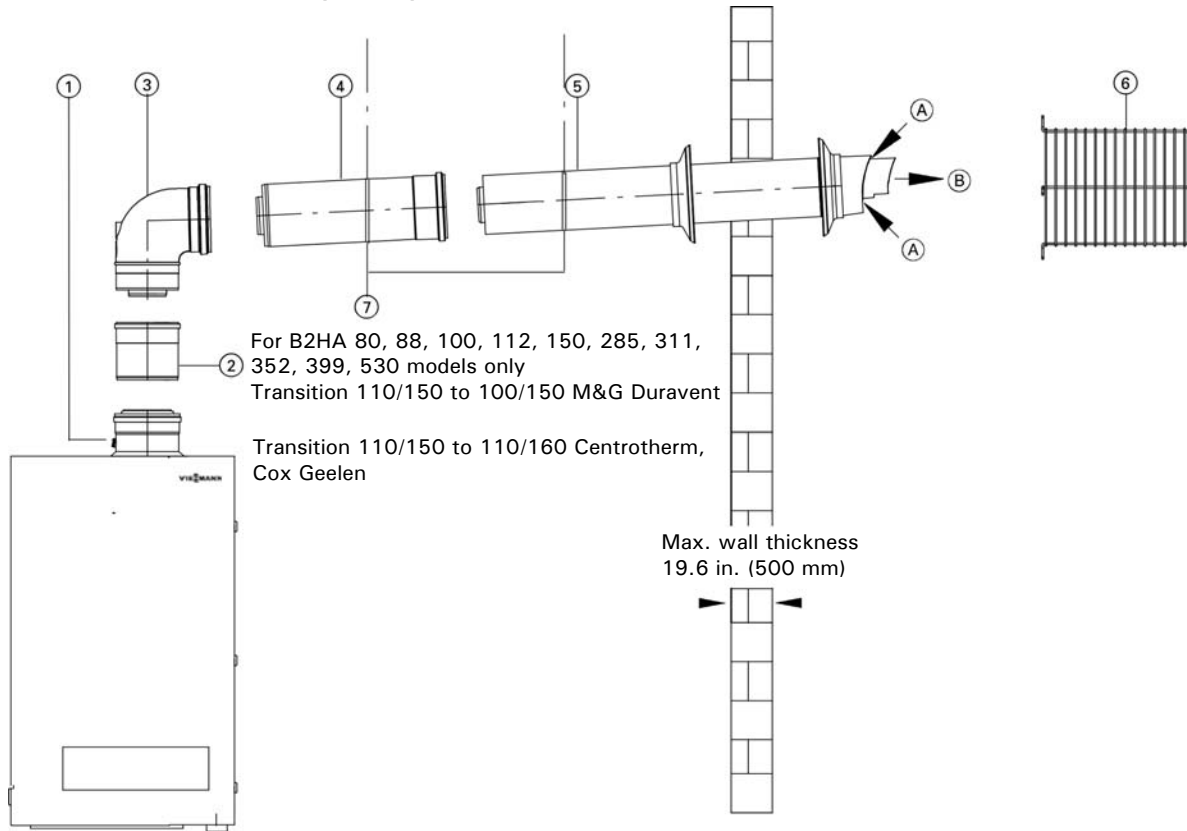

Standard side wall venting layout

Standard sizes of boiler flue gas adaptors (item ①)

Boiler model	Adaptor Size
B1HA 26, 35, 94, 125	60 / 100
B1KA 35, 125	60 / 100
B1HE 85, 120, 150, 199	80 / 125
B1KE 120, 199	80 / 125
B2TB 19, 35, 68, 125	60 / 100
B2HA 19, 28, 35	60 / 100
B2HB 19, 26, 35, 68, 94, 125	60 / 100
B2HA 45, 60	80 / 125
B2HB 45, 57, 160, 199	80 / 125
B2HA 80, 88, 100, 112, 150, 285, 311, 352, 399, 530	110 / 150
B2HE 85, 120, 150, 199	80 / 125

Legend

- ① Vent pipe adaptor
- ② Transition adaptors
M&G Duravent, PolyFlue 110/150 to 100/150 or
InnoFlue Centrotherm, Cox Geelen 110/150 to 110/160
- ③ Elbow, 87°
- ④ Straight pipe
- ⑤ Vent termination (incl. wall flashings)

IMPORTANT

Total length of vent termination pipe may be shortened, if required. Follow manufacturer's instructions.

- ⑥ Protective screen

WARNING

Protective screen **MUST** be installed.

- ⑦ Mounting clip (vent support system)
- Ⓐ Combustion air intake
- Ⓑ Flue gas outlet

Side Wall Venting Layouts (Coaxial) *(continued)*

Layout with basic coaxial vent componentry *(continued)*

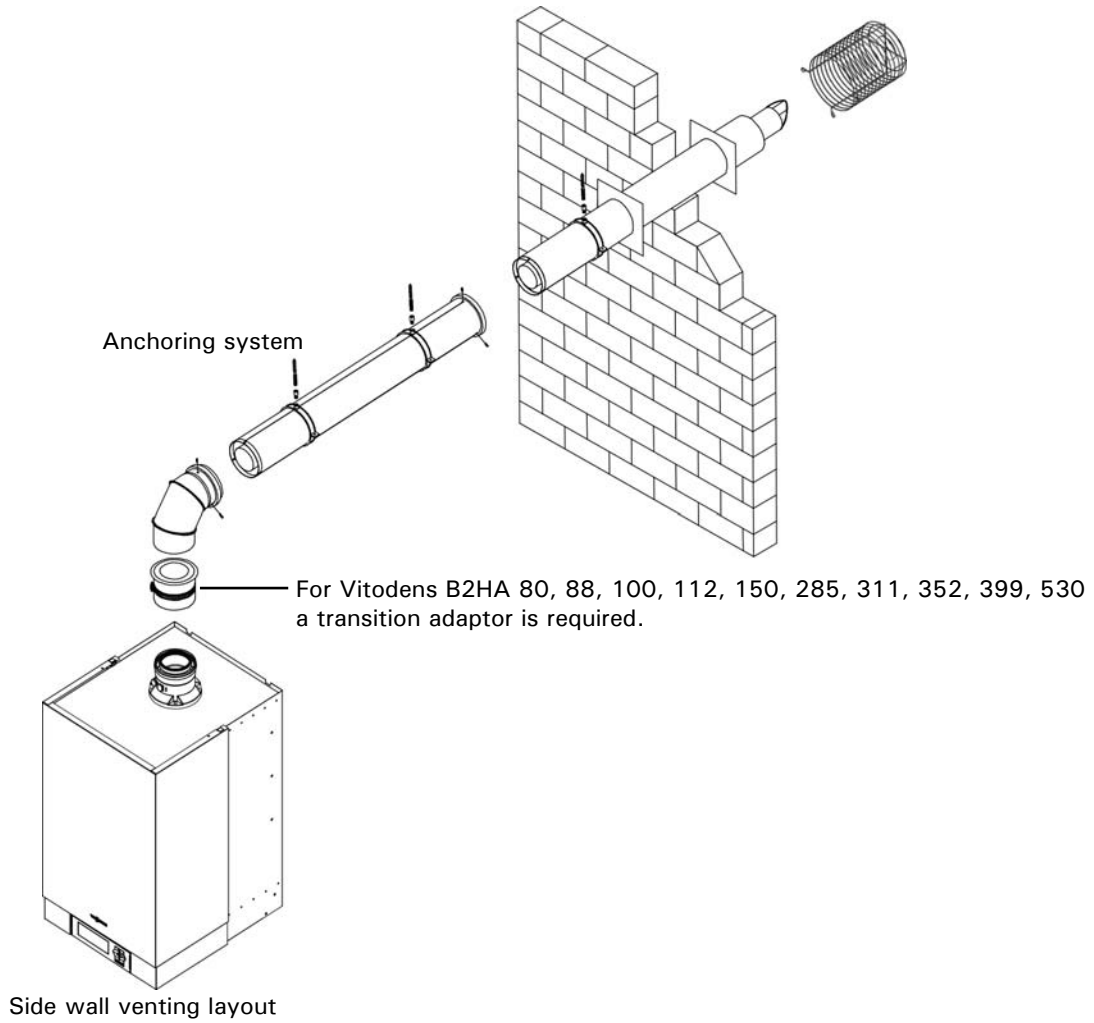

Boiler model	B2HA 80, 88, 100, 112, 150, 285, 311, 352, 399						
	a	b	c	d	e	f	g
M&G/Duravent, PolyFlue in. (mm)	4.3 (110)	6 (150)	1.3 (40)	2 (50)	5.5 (140)	4 (100)	6 (150)
Innoflue Centrotherm, Z-Flex, ECCO, Cox Geelen in. (mm)	4.3 (110)	6 (150)	1.3 (40)	2 (50)	5 ³ / ₈ (137)	4.3 (110)	6.3 (160)

Transition adaptor,
for models
B2HA 80, 88, 100, 112, 150,
285, 311, 352, 399, 530

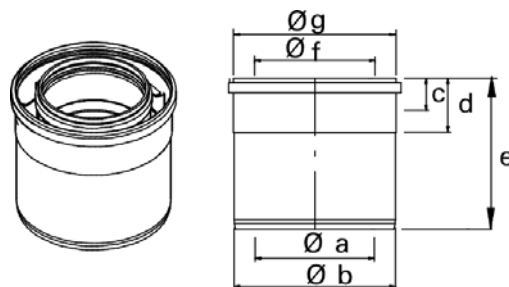

Side Wall Venting Layouts (Coaxial) *(continued)*

Layout with basic coaxial vent componentry *(continued)*

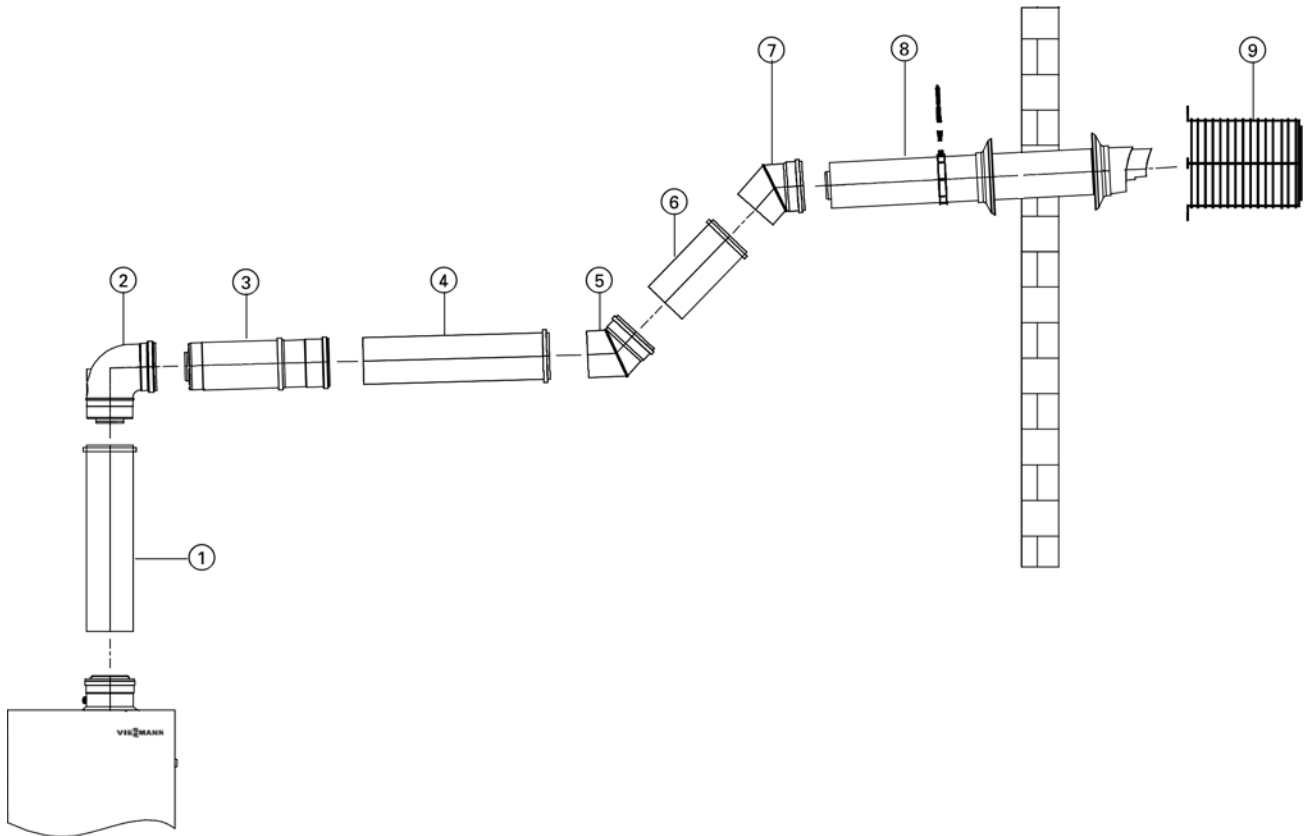

Side wall venting layout

For Vitodens B2HA 80, 88, 100, 112, 150, 285, 311, 352, 399, 530 a transition adaptor is required (see page 17).

Note: The vent system must be properly supported without sagging. The Vitodens boilers are not designed to support the weight of the venting system.

Legend

- ① Straight pipe
- ② Elbow, 87°
- ③ Telescopic extension (sliding coupling)
- ④ Straight pipe
- ⑤ Elbow
- ⑥ Straight pipe
- ⑦ Elbow
- ⑧ Vent termination (incl. wall flashings)
- ⑨ Protective screen

IMPORTANT

Total length of vent termination pipe may be shortened if required. Follow manufacturer's instructions.

WARNING
Protective screen **MUST** be installed.

Wall Mounted Multiple Boiler Horizontal Vent Terminations

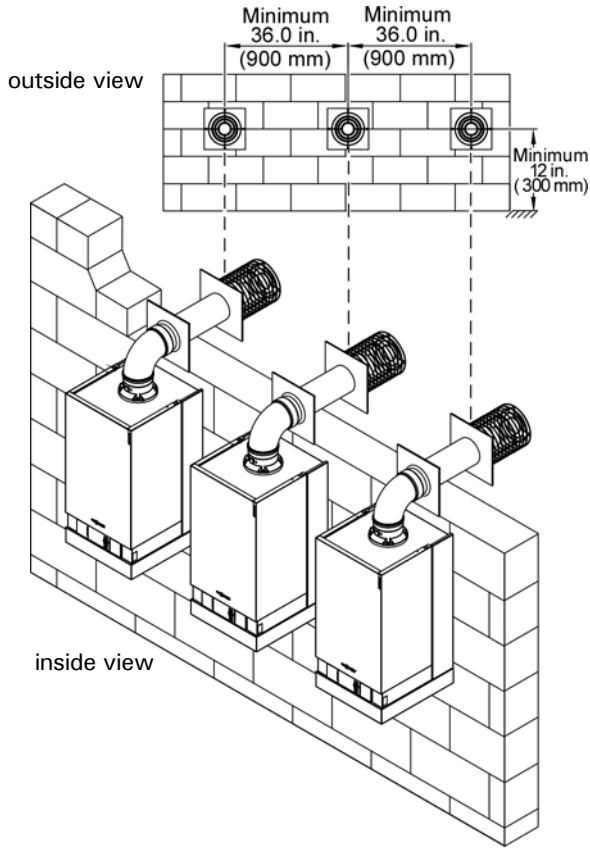

Note: Minimum vent height above anticipated snow level as shown.

Manifold Mounted Multiple Boiler Horizontal Vent Terminations

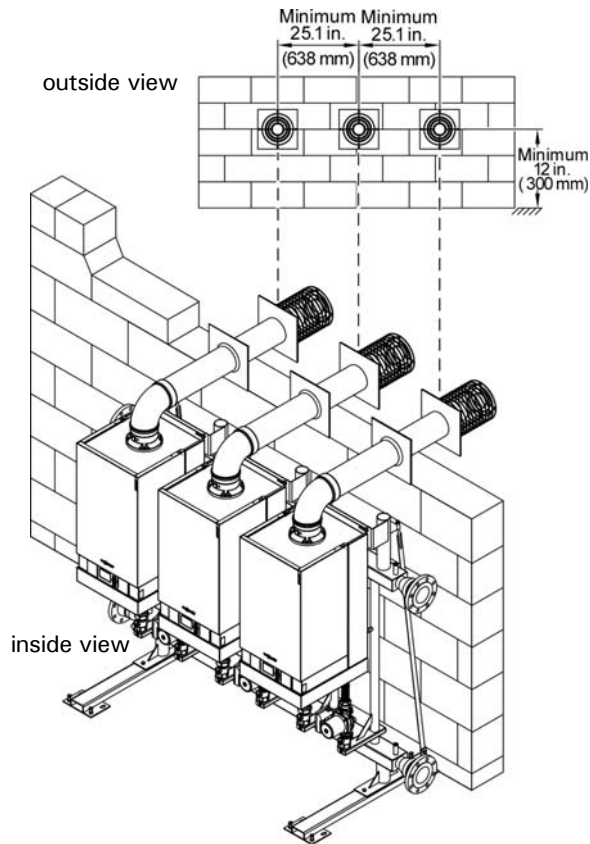

Note: Minimum vent height above anticipated snow level as shown.
Vent termination must be aligned horizontally.

Coaxial Vent Termination

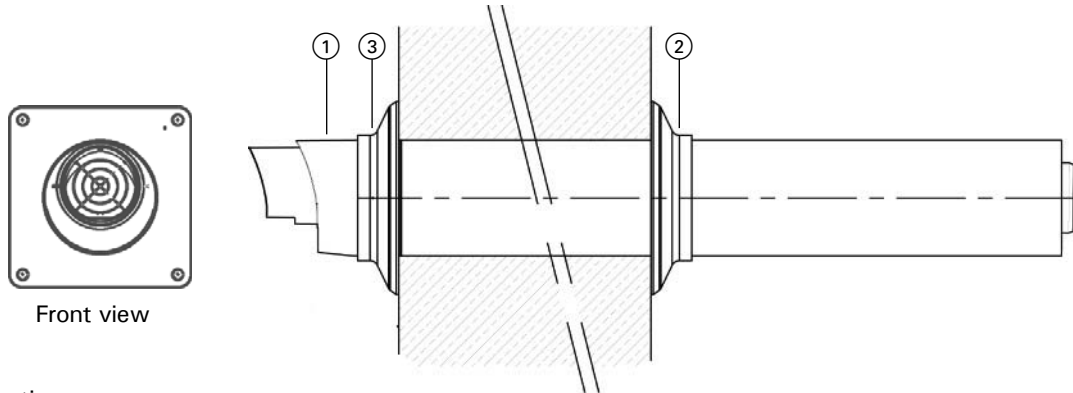

Legend

- ① Vent termination
- ② Wall flashing (inside)
- ③ Wall flashing (outside)

Wall opening information

Vent system	Opening Ø
60/100 M&G/Duravent, PolyFlue, Z-Flex, ECCO*, Centrotherm InnoFlue, Cox Geelen	4¼ in. (108 mm)
80/125 M&G/Duravent, PolyFlue, Z-Flex, ECCO*, Centrotherm InnoFlue, Cox Geelen	5¼ in. (133 mm)
100/150 M&G/Duravent, PolyFlue	6¾ in. (160 mm)
110/160 Z-Flex, Cox Geelen, Centrotherm InnoFlue, ECCO*	6 ¹¹ / ₁₆ in. (170 mm)

* Coaxial termination requires adaptor from 2 pipe system

Side wall vent termination installation

1. Provide side wall opening (see table above) to install vent termination.
2. Slide vent termination ① with wall flashing ③ into opening (drain openings must be located on the outside of the wall, pointing downward).
3. Attach wall flashing ② to inside of wall using the screws and plugs provided.
4. Attach wall flashing ③ to outside of wall.

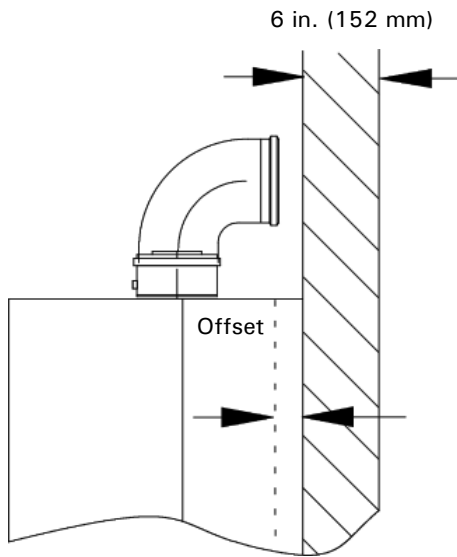

IMPORTANT

Potential gaps between the vent-air intake and the surrounding construction which may cause air, rain or flue gases to leak into the wall or the building, must be sealed with approved outdoor sealant/caulking to prevent leakage of any kind.

When installing a side wall vent system with the minimum equivalent vent length (87° elbow and vent termination, a wall thickness of at least 6 in. (152 mm) is required. For walls with a thickness less than 6 in. (152 mm), means must be provided to offset the boiler from the wall (see illustration above).

IMPORTANT

If required the vent termination may be shortened.

Coaxial Vent Termination *(continued)*

Note: Termination may not be exactly as shown, refer to the vent manufacturers specific component specifications.



Refer to the vent manufacturers Installation Instructions.

Protective screen

1. Secure protective screen (A) into place, using the four stainless steel screws and anchors.

IMPORTANT

The protective screen MUST be installed.

2. Connect vent termination from inside and ensure the vent termination has a min. 3° downward slope toward the boiler.

Protective screen, side view for vent system (all sizes).

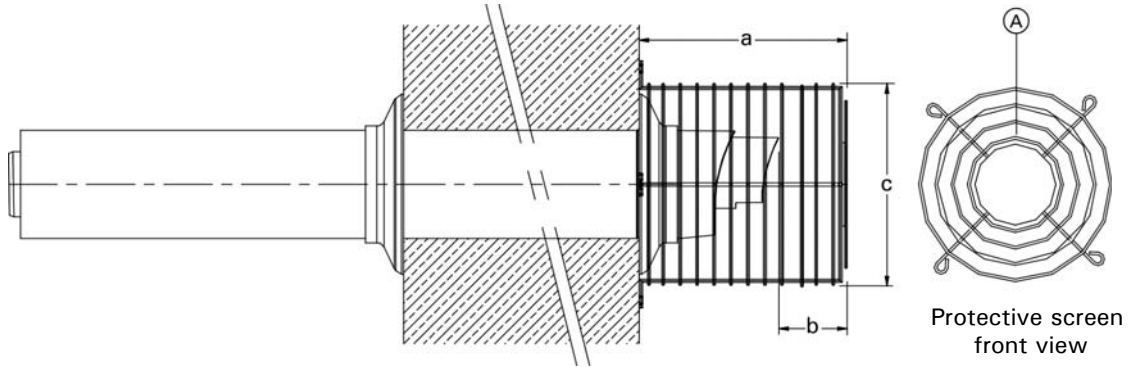

Dimensions

a	b	c
12 in. (305 mm)	must be at least 4 in.	9.5 in. (241 mm)

Venting Length

Boiler model	Vent system		
	60/100	80/125	100/150 or 110/160
B1HA 26, 35, 94, 125	82 ft. (25 m)	98 ft. (30 m) * ¹	118 ft. (36 m) * ²
B1KA 35, 125	82 ft. (25 m)	98 ft. (30 m) * ¹	118 ft. (36 m) * ²
B1HE 85, 120	43 ft. (13 m)* ⁶	98 ft. (30 m)	118 ft. (36 m)* ³
B1HE 150, 199	--	33 ft. (10 m)	43 ft. (13 m)* ³
B1KE 120	43 ft. (13 m)* ⁶	98 ft. (30 m)	118 ft. (36 m)* ³
B1KE 199	--	33 ft. (10 m)	43 ft. (13 m)* ³
B2TB 19, 35, 68, 125	33 ft. (10 m)	40 ft. (12 m)* ¹	50 ft. (15 m)* ²
B2HA 19, 28, 35	33 ft. (10 m)	40 ft. (12 m)* ¹	50 ft. (15 m)* ²
B2HB 19, 26, 35, 68, 94, 125	33 ft. (10 m)	40 ft. (12 m)* ¹	50 ft. (15 m)* ²
B2HA 45	--	33 ft. (10 m)	43 ft. (13 m)* ³
B2HA 60	--	20 ft. (6 m)	30 ft. (9 m)* ³
B2HB 45, 160	--	33 ft. (10 m)	43 ft. (13 m)* ³
B2HB 57, 199	--	20 ft. (6 m)	30 ft. (9 m)* ³
B2HA 80, 88, 100, 285, 311, 352	--	--	43 ft. (13 m)
B2HA 112, 399	--	--	26 ft. (8 m)* ⁵
B2HA 150, 530	--	--	16 ft. (5 m)* ⁴
B2HE 85, 120	43 ft. (13 m)* ⁶	98 ft. (30 m)	118 ft. (36 m)* ³
B2HE 150, 199	--	33 ft. (10 m)	43 ft. (13 m)* ³

*¹ If used with increasers 60/100 to 80/125.

*² If used with increasers 60/100 to 100/150.

*³ If used with increasers 80/125 to 100/150.

*⁴ Boilers have an input reduction of 13% with any coaxial length used.

*⁵ Boilers have an input reduction of 5% with any coaxial length used.

*⁶ Requires 80/125 to 60/100 reducer.

Venting Length *(continued)*

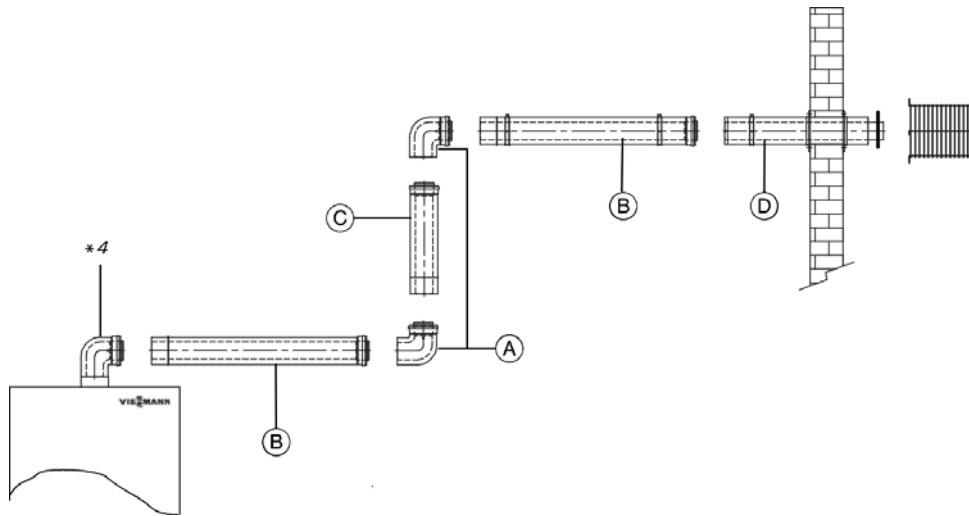

Equivalent vent length calculation

Legend

- (A) 87° elbow
- (B) Vent pipe 3.3 ft. (1 m)
- (C) Vent pipe 1.6 ft. (0.5 m)
- (D) Vent termination

*4 First elbow not included in equivalent vent calculation.

Equivalent vent length calculation example

2 x 87° elbow.....	3.2 ft. (1 m)
2 x vent pipe (1 m).....	6.6 ft. (2 m)
1 x vent pipe (0.5 m).....	1.6 ft. (0.5 m)
1 x vent termination.....	2.4 ft. (0.73 m)
Total equivalent length.....	13.8 ft. (4.23 m)

- Do not exceed the maximum vent length.
- First 87° elbow on boiler is not included in equivalent vent length calculation.

IMPORTANT

First elbow is excluded from in equivalent vent calculation. Always include vent termination length in calculations.

Note: Depending on the selected vent manufacturer, a service clearance of 36 in. may be required. Consult the vent manufacturer if using two-pipe to coaxial adaptor directly at the back of the boiler.

Type of fitting	Equivalent length
87° elbow/ 87° inspection tee	1.6 ft. (0.5 m)
45° elbow	1 ft. (0.3 m)

Equivalent lengths of venting components may vary between vent manufacturers, use manufacturers values when calculating vent system equivalent lengths.

A 10% boiler input reduction @ 99 ft. (30 m) for all sizes and all configurations.

Vertical Venting Layouts (Coaxial) *(continued)*

General installation examples

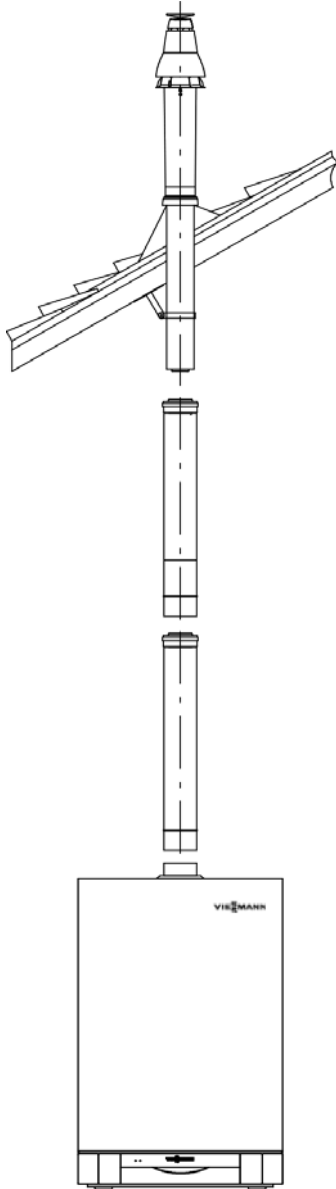

Sloped roof installation

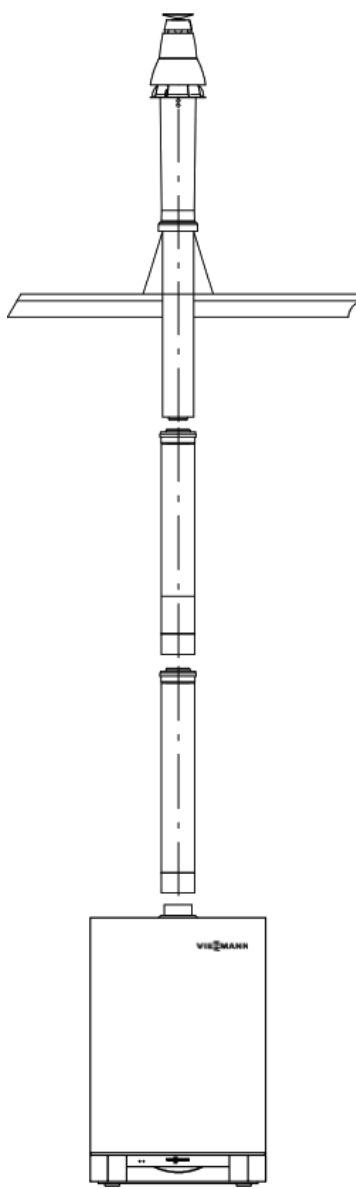

Flat roof installation

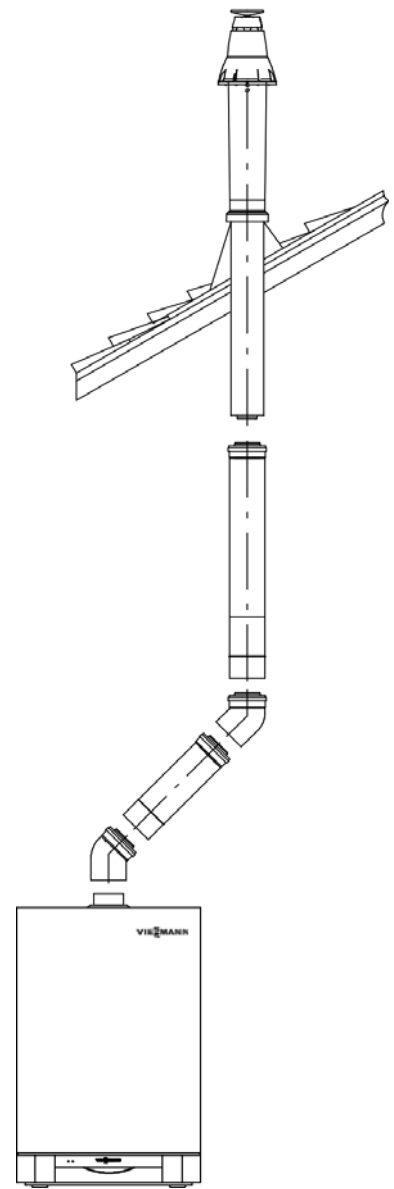

Sloped roof installation with offset

IMPORTANT

Ensure that the venting system is properly supported; the Vitodens 100-W, 222-F and Vitodens 200-W boilers are not designed to support the weight of the venting system.

Coaxial vent termination installation

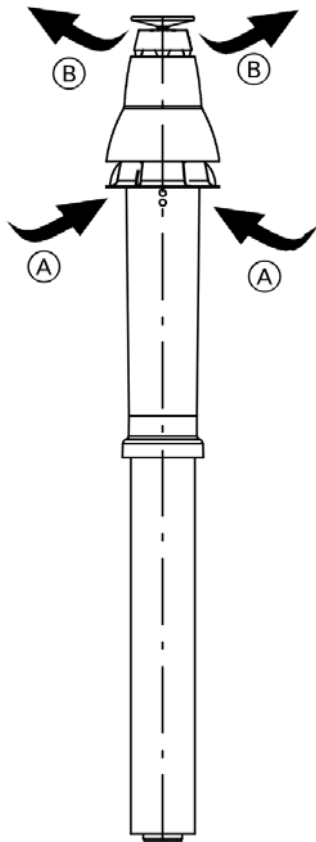

Legend

- (A) Combustion air intake
- (B) Flue gas outlet

Coaxial venting must terminate at the same elevation

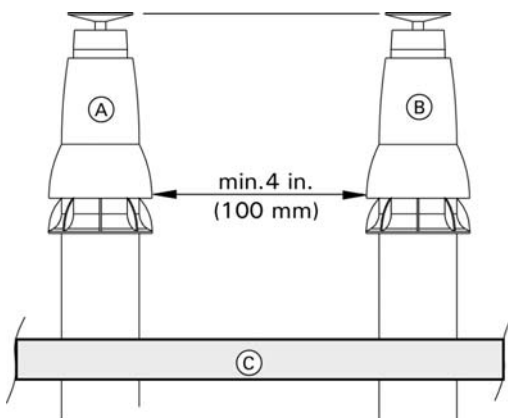

Legend

- (A) Termination boiler 1
- (B) Termination boiler 2
- (C) Roof

Wall opening information

Vent system	Opening Ø
60/100 M&G/Duravent, PolyFlue, Z-Flex, ECCO*, Centrotherm InnoFlue, Cox Geelen	4¼ in. (108 mm)
80/125 M&G/Duravent, PolyFlue, Z-Flex, ECCO*, Centrotherm InnoFlue, Cox Geelen	5¼ in. (133 mm)
100/150 M&G/Duravent, PolyFlue	6⅜ in. (160 mm)
110/160 Z-Flex, Cox Geelen, Centrotherm InnoFlue, ECCO*	6 ¹¹ / ₁₆ in. (170 mm)

* Coaxial termination requires adaptor from 2 pipe system

Vertical vent termination installation

1. Install the vent termination for sloped or flat roof collars and flashings in accordance with the manufacturer's instructions.
2. The vent termination should be placed from above on the sloped or flat roof collar.
3. Connect vent pipe from below.

Multiple boiler installations (vertical coaxial termination with multiple boilers)

When terminating the vertical vent pipes of multiple Vitodens boilers, a minimum clearance of 4 inches (100 mm) is required (refer to illustrations).

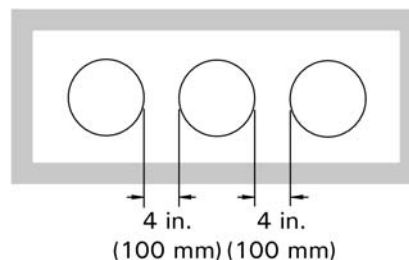
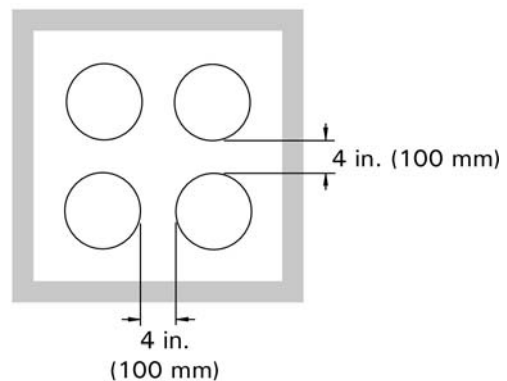

Installation of Support System

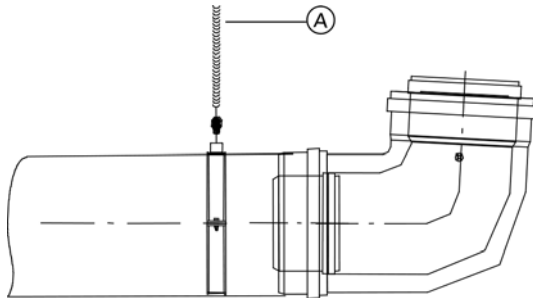

The venting system must be securely supported by an anchoring system (A) suitable for the weight and design of the materials employed.

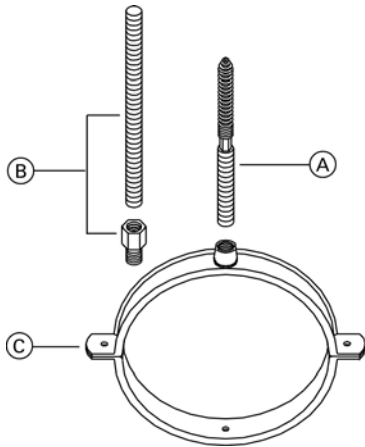

If a longer anchoring system is required use all-threaded rods (B) (field supplied).

The venting system must be securely supported by a support system suitable for the weight and design of the materials employed.

Contact your vent material supplier for more information specific to your installation.

Supports

Supports are used to transfer the weight of an installation to the building structure. There are different types of supports and their capacity varies with each type and diameter.

The following support types are available at your local vent material supplier...

- anchor plate
- wall support
- roof support
- floor support
- suspension band (hanger).

In addition to the support types listed above Viessmann offers mounting clips which can be used in conjunction with the above support types to support the weight of the venting system. Please contact Viessmann to order.

Vertical vent systems with horizontal sections must have the joints in these sections secured with the supplied sheet metal screws (A) to prevent the system from sagging.

The 4 in. (101.6 mm) screws (D) supplied with the mounting clip provide wall or ceiling support for a ...

- minimum distance of 2 in. (50.8 mm)
- maximum distance of 3¼ in. (82.5 mm).

If a longer support system is required use a brass adaptor M8 x 5/16 in. (field supplied) with 5/16 in. all threaded rods (B) (field supplied).

Bracing

Contact your local vent material supplier for more information specific to your installation.

Braces are required to stabilize an installation. There are different types and their use and spacing vary.

The following types of braces are available at your local vent material supplier...

- wall band
- wall band extension
- guy wire band
- roof brace.

IMPORTANT

Ensure that the venting system is properly supported; the Vitodens boiler is not designed to support the weight of the venting system.

Vent Length Requirements

Maximum vent length

Boiler model	a (max. length)	B1HA 26, 35, 94, 125 B1KA 35, 125
60/100	ft. (m)	82 (25)
80/125	ft. (m)	--
100/150 or 110/160	ft. (m)	--

Boiler model	a (max. length)	B2TB 19, 35, 68, 125	B2HA 19, 28, 35, B2HB 19, 26, 35, 68, 94, 125	B2HA 45 B2HB 45, 160	B2HA 60 B2HB 57, 199	B2HA 80, 88, 100, 285, 311, 352	B2HA 112, 399	B2HA 150, 530
60/100	ft. (m)	33 (10)	33 (10)	--	--	--	--	--
80/125	ft. (m)	--	--	33 (10)	20 (6)	--	--	--
100/150 or 110/160	ft. (m)	--	--	--	--	43 (13)	26 (8)* ₂	16 (5)* ₁

Boiler model	a (max. length)	B1HE 85, 120 B1KE 120 B2HE 85, 120	B1HE 150, 199 B1KE 199 B2HE 150, 199
60/100	ft. (m)	43 (13)* ₃	--
80/125	ft. (m)	98 (30)	33 (10)
100/150 or 110/160	ft. (m)	118 (36)	43 (13)

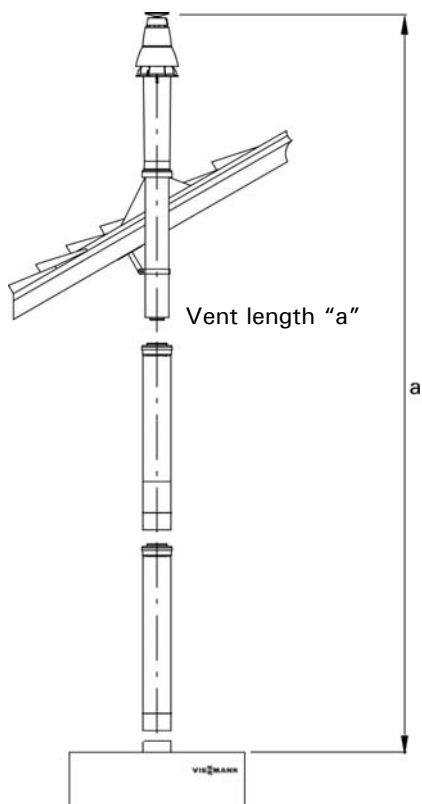

- *₁ Boilers have an input reduction of 13% with any coaxial length used.
- *₂ Boilers have an input reduction of 5% with any coaxial length used.
- *₃ Requires 80/125 to 60/100 reducer.

Do not exceed the maximum vent length.

See tables on page 29 for increased diameter equivalent vent pipe system.

Vent Length Requirements *(continued)*

Maximum vent length with increasers

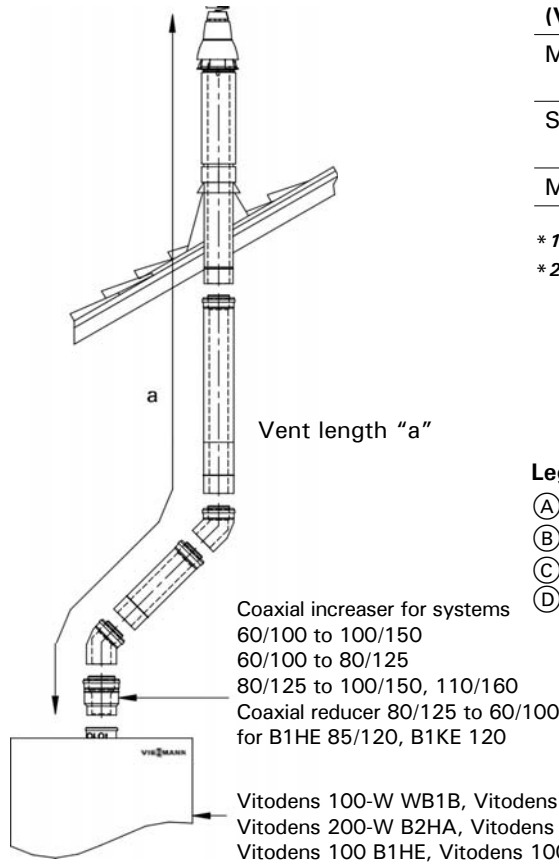

Maximum vent length for vertical installations (Vitodens 100-W)

Model No.	B1HA 26, 35, 94, 125 B1KA 35, 125		
System vent size		80/125*1	100/150*2 110/160
Max. vent length "a"	ft. (m)	98 (30)	118 (36)

*1 If used with increasers 60/100 to 80/125.

*2 If used with increasers 60/100 to 100/150, 110/160

Legend

- (A) 87° elbow
- (B) Vent pipe 3.3 ft. (1 m)
- (C) Vent pipe 1.6 ft. (0.5 m)
- (D) Vent termination

Maximum vent length for vertical installations (Vitodens 200-W)

Model No.		B2TB 19, 35, 68, 125		B2HA 19, 28, 35 B2HB 19, 26, 35, 68, 94, 125		B2HA 45 B2HB 45, 160	B2HA 60 B2HB 57, 199
System vent size		80/125	100/150 or 110/160	80/125	100/150	100/150	100/150
Max. vent length "a"	ft. (m)	40 (12)*1	49 (15)*2	40 (12)*1	49 (15)*2	43 (13)*3	30 (9)*3

Maximum vent length for vertical installations (Vitodens 200-W)

Model No.		B1HE 85, 120 B1KE 120 B2HE 85, 120			B1HE 150, 199 B1KE 199 B2HE 199	
System vent size		60/100	80/125	100/150 or 110/160	80/125	100/150 or 110/160
Max. vent length "a"	ft. (m)	43 (13)*4	98 (30)	118 (36)*3	33 (10)	43 (13)*3

*1 If used with increasers 60/100 to 80/125.

*2 If used with increasers 100/150 or 110/160

*3 If used with increasers 80/125 to 100/150 or 110/160

*4 If used with reducer 80/125 to 60/100

Minimum vent length

The minimum equivalent vertical vent length for all models is 4 ft. (1.2 m) (= length of vent termination).

Vent Length Requirements *(continued)*

Equivalent vent length calculation example

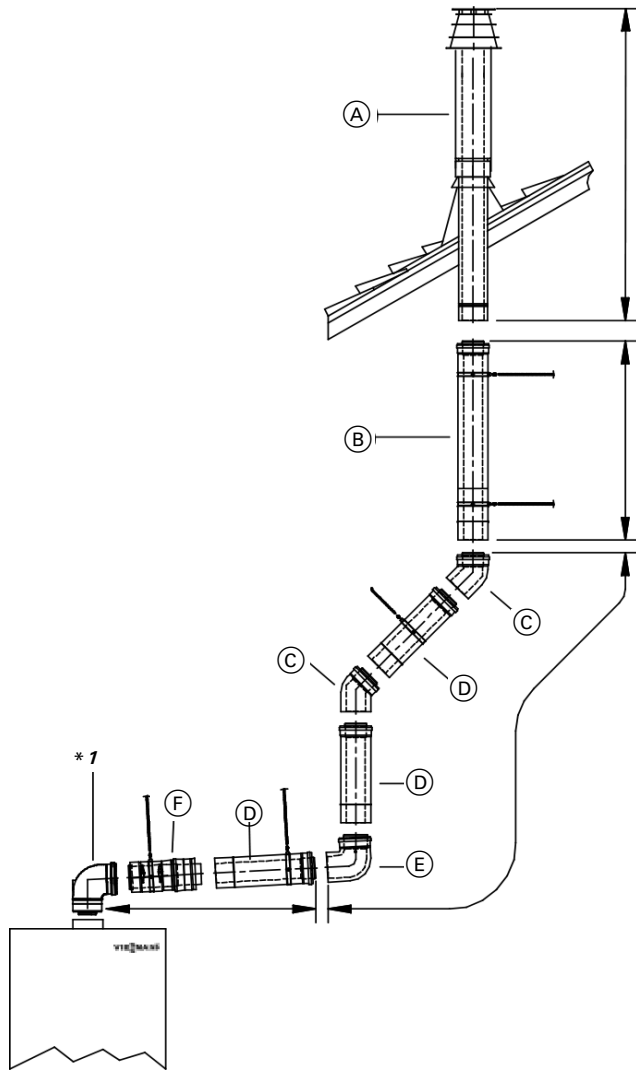

Equivalent vent length calculation example

Legend

- (A) Vent termination
- (B) Vent pipe 3.3 ft. (1 m)
- (C) 45° elbow
- (D) Vent pipe 1.6 ft. (0.5 m)
- (E) 87° elbow
- (F) Telescopic extension

* 1 First elbow not included in equivalent vent calculation.

Type of fitting	Equivalent length
87° elbow/ 87° inspection tee	1.6 ft. (0.5 m)
45° elbow	1 ft. (0.3 m)

IMPORTANT

Always include vent termination length in calculations.

Equivalent lengths of venting components may vary between vent manufacturers, use manufacturers values when calculating vent system equivalent lengths.

Equivalent vent length calculation example:

Vitodens 100-W WB1B 35 or Vitodens 100-W B1HA/B1KA 35
or Vitodens 200-W WB2B 35 or Vitodens 200-W B2HA/B2HB
35 or Vitodens 222-F B2TA/B2TB 35
(vent system 60/100) (see illustration on this page).

2 x 87° elbow.....	3.3 ft. (1 m)
2 x 45° elbow.....	2 ft. (0.6 m)
3 x vent pipe.....	4.8 ft. (1.5 m)
1 x vent pipe.....	3.3 ft. (1 m)
1 x telescopic extension (average length)...	1.0 ft. (0.31 m)
1 x vent termination.....	4.2 ft. (1.28 m)
Total equivalent length.....	18.6 ft. (5.67 m)

Standard sizes of boiler flue gas adaptors*1

Boiler model	Adaptor Size
B1HA 26, 35, 94, 125	60 / 100
B1KA 35, 125	60 / 100
B1HE 85, 120, 150, 199	80 / 125
B1KE 120, 199	80 / 125
B2TB 19, 35, 68, 125	60 / 100
B2HA 19, 28, 35	60 / 100
B2HB 19, 26, 35, 68, 94, 125	60 / 100
B2HA 45, 60	80 / 125
B2HB 45, 57, 160, 199	80 / 125
B2HA 80, 88, 100, 112, 150, 285, 311, 352, 399, 530	110 / 150
B2HE 85, 120, 150, 199	80 / 125

General Installation Information

Installation steps (outline)

Exhaust and combustion air piping material

Use only the materials listed on the table entitled "Approved materials for two-pipe system" on page 32 for exhaust, combustion air intake pipe and fittings.

- Cut the pipe end square and remove all burrs and debris from joints and fittings.
- If using CPVC special vent material for exhaust vent pipe and ABS / PVC / CPVC for combustion air intake pipe, all joints must be properly cleaned, primed and cemented. Use only cement and primer approved for the use with the pipe material. See table entitled "Approved materials for two-pipe system" on page 32 for approved solvent cement material.

CAUTION

For solvent cement and primer:

- Use only in well ventilated areas
- Do not use near flame or open fire
- Use only the solvent cement and primer appropriate for the venting material being used
- Solvent cements for plastic pipe are flammable liquids and must be kept away from all sources of ignition

- For rigid PP(s) venting system only; Venting material must be ULC S636 or UL 1738 listed, (see page 42 for listed manufacturers).
- No low point is allowed in the exhaust vent pipe system, unless a proper drain pipe is used to allow condensate to drain.

WARNING

Ensure that the entire venting system is protected from physical damages. A damaged venting system may cause unsafe conditions.

WARNING

The venting system is approved for indoor installations only. Do not install the venting system outdoors.

- Route vent pipe as directly as possible and with as few bends as possible to the boiler.
- Condensate must drain from the flue pipe to the boiler. Ensure a suitable gradient of at least 2-3° based on the vent manufacturer's system design [example: for a 3° system approx. 2 in. per 3.3 ft. (50 mm per 1 m) on any horizontal venting components].
- Use a hacksaw or sheet metal snips (for stainless steel) to cut pipes to length (if necessary). Use a file to smooth rough edges. Pipe must be round and not bent into an oval shape.
- Check proper location of gaskets in rigid PP(s) pipe collars. (Only use supplied parts with the polypropylene venting system).
Apply water (or lubricant supplied with the venting system) to lubricate the joint ends of the vent pipe collar and if used, the air intake pipe collar.
- Slide pipes into each other with a gentle twisting motion.

IMPORTANT

When cutting pipes to length, debur and clean pipes. In conjunction with these instructions, follow the installation instructions supplied by the special venting manufacturer.

- All piping must be fully supported. Use pipe hangers at intervals specified by manufacturers to prevent sagging of the pipe.
- The exhaust vent/air intake pipe and fittings must be securely supported by a support system suitable for the weight and design of the material employed. Contact your local vent material supplier for more information specific to your installation(s).

IMPORTANT

Ensure that the exhaust vent/air intake pipes are properly supported. The Vitodens boiler is not designed to support the weight of the exhaust vent/air intake pipe system.

- Field supplied increaser fittings (transition) should always be inserted in vertical sections of pipe to prevent accumulation of condensate in the vent pipe.
- The total equivalent length specified for a two-pipe system is the total of the combined length of the exhaust vent/air intake pipe system. Do not exceed these maximum lengths.

General Installation Information *(continued)*

Approved combustion air intake materials

Part	Material	Certified to Standards	Applicability
Combustion air pipe and fitting	Stainless steel	No applicable standards	U.S.A./Canada
	Galvanized steel	Suitable for outdoor use	
	PVC-DWV Schedule 40	ANSI/ASTM D2661 CSA B181.1 ULC S102.2 ANSI/ASTM D2665, D1785 CSA B137.3, B181.2 ANSI/ASTM F441	
	CPVC Schedule 40	ANSI/ASTM D2661 CSA B181.1 ULC S102.2 ANSI/ASTM D2665, D1785 CSA B137.3, B181.2 ANSI/ASTM F441	
	ABS-DWV Schedule 40	ANSI/ASTM D2661 CSA B181.1 ULC S102.2 ANSI/ASTM D2665, D1785 CSA B137.3, B181.2 ANSI/ASTM F441	
	Polypropylene PP(s)	UL1738 "Venting systems for gas-burning appliances, Categories II, III, IV" ULC S636 "Standard for Type BH gas venting systems" Class IIC 110°C	
Pipe cement, primer (for combustion air intake pipe)	PVC	ANSI/ASTM D2564 CSA B137.3	
	CPVC	ANSI/ASTM F493 CSA B137.6	
	ABS	ANSI/ASTM D2235 CSA B181.1/B182.1	

Note: Always use the latest edition of the applicable standard.

 **CAUTION**

Do not use cellular (foam) core pipe material to vent this Vitodens boiler.

 **CAUTION**

On the job site, ensure that non-listed combustion air pipe materials are not inadvertently used instead of listed vent pipe material.

 **CAUTION**

Do not use PVC material in exhaust system.

Exhaust Vent/Air Intake Requirements

Combustion Air Supply

The Vitodens boiler is suitable for sidewall, as well as vertical venting. The Vitodens 100-W, 222-F and 200-W boilers are approved for both direct vent (sealed combustion), as well as direct exhaust (non-sealed combustion) operation in both horizontal and vertical arrangements. For non-sealed combustion vent systems (i.e. room-air dependent), see appropriate section under "Single Pipe Venting" starting on page 59 in this manual.

The boiler must be connected to a direct vent system in which all air for combustion is taken from the outside atmosphere and all combustion products are discharged safely to the outdoors.

The boiler must be vented and supplied with combustion air and exhaust vent as described in this section. Ensure the vent and combustion air supply comply with these instructions.

 **CAUTION**
Do not locate boiler in areas where high dust levels or high humidity levels are present.

 **CAUTION** *
Do not install boiler during construction involving drywall or heavy dust of any kind. Dust can accumulate in the burners and cause sooting. Install boiler after all heavy dust construction is completed.

* Typically when the boiler is used as a temporary heat source during the building construction phase.

Inspect all finished exhaust vent/air intake piping to ensure:

- Vent/air intake pipe and fittings are of approved material.
- Acceptable size, length and number of elbows on combined vent/air intake system.
- Installation is in accordance with prevailing provisions of local codes.
- Installation complies with the requirements of these instructions, as well as the exhaust vent/air intake supplier's instructions.

The exhaust vent and combustion air intake system and terminations may be installed in one of the following type terminations (2-pipe system):

1. Horizontal air intake and exhaust vent pipes.
2. Vertical air intake and exhaust vent pipes.
3. Horizontal air intake pipe and vertical exhaust vent pipe.

If there is moisture or high humidity existing in the room where the combustion air intake is installed, condensation formation on the inlet pipe may occur. Either a type 'B' (insulated) pipe or an insulated inlet pipe shall be used.

 **CAUTION**
If the boiler has been exposed to high dust levels, all burners and the heat exchanger must be cleaned prior to use.

 **CAUTION**
If above criteria are not properly observed and boiler damage results, any warranty on the complete boiler and related components will be null and void.

Exhaust Vent/Air Intake Requirements *(continued)***General requirements**

The Vitodens 100-W, 222-F and 200-W boilers must be located in such a way that the vent length is as short as possible and that the vent can be routed as directly (and with as few bends) as possible.

The minimum equivalent vent length is 3.3 ft. (1 m). See tables starting on page 47 for maximum and minimum vent lengths.

All products of combustion must be safely vented to the outdoors. All Vitodens boilers vent under positive pressure and are Category IV boilers.

WARNING

Failure to ensure that all flue gases have been safely vented to the outdoors can cause property damage, severe personal injury, or loss of life. Flue gases may contain deadly carbon monoxide.

Viessmann recommends that the entire vent system be checked by a licensed professional heating contractor at least once each year following initial installation.

The stainless steel special venting system is completely sealed when fully assembled. Locking bands or other method of joining are used to reinforce the joints between pipe and fittings.

The remaining space surrounding a chimney liner, gas vent, or special gas vent or plastic piping installed within a masonry, metal or factory-built flue shall not be used to supply combustion air to the boiler. A separate combustion air intake pipe routed back to the boiler can be used in the remaining space if required, the boiler venting system is approved for zero clearance, and can be run directly beside the combustion air intake pipe.

WARNING

Different manufacturers offer a number of different joint systems and adhesives. Do not mix pipes, fittings and/or joining methods from different manufacturers. Failure to comply could result in leakage, potentially causing personal injury or death.

Do not install vent pipe in a way that flue gases flow downwards. The direction of flue gas flow must be vertically upwards or horizontal with an upward slope.

Ensure there is no flue gas leakage into the area in which the boiler is installed.

Check joints for leaks with the gas supply turned off and the fan running. Use a soapy solution to check for vent leaks.

Condensate must drain from the flue pipe to the boiler. Ensure a suitable gradient of at least 2-3° based on the vent manufacturer's system design [example: for a 3° system approx. 2 in. per 3.3 ft. (50 mm per 1 m) on any horizontal venting components].

No condensate trap is required in the vent pipe system.

If exhaust vent pipe system passes through an unheated space, such as an attic, it must be insulated. The insulation must have an R value sufficient to prevent freezing of the condensate. Armaflex insulation with ½ in. thickness and higher can be used.

Vent Requirements - Stainless Steel

Additional requirements for stainless steel vent pipe material

Use special stainless steel venting system (UL/ULC listed for category IV) for horizontal or vertical venting of the Vitodens boilers.

See tables on page 39, and contact the suppliers to order.

Prior to installation, check that the correct single-pipe vent parts were ordered and supplied.

See table on page 38 for special parallel/starter adaptor and bird screen models required for your installation. In case of discrepancies, contact original parts supplier.

Exhaust vent/air intake connection to boiler:
The vent connection to the Vitodens boiler must be made with the starter stainless steel adaptor (supplied by others and/or parallel adaptor see table on page 38). The starter adaptors are intended for a slip fit and slide into the parallel adaptor with a gentle twisting motion.

Combustion air intake pipe:
If the venting system will use CPVC/ABS, PVC plastic pipe for combustion air intake, a CPVC starter adaptor for use on air intake connection to parallel adaptor must be ordered from Viessmann (see table on page 38). The bird screen for the air intake termination elbow must also be ordered from Viessmann.

Note: The Vitodens boiler has passed the zero inches vent clearance to combustibles testing requirements dictated by the Harmonized Standard ANSI Z21.13. CSA 4.9 and therefore is listed for zero clearance to combustibles when vented with a single pipe special venting system. The zero inches vent clearance to combustibles for the Vitodens boiler supersedes the clearance to combustibles listing that appears on the special venting system label.

Viessmann single pipe PP(s) increaser and 2 in. air intake CPVC adaptor (if using ABS/CPVC/PVC material) must be ordered, (see table below for part number).

Minimum pipe diameter available for exhaust stainless steel pipe is 3 in.

The air inlet (intake) cover must stay in place.

PolyFlue - Selkirk www.polyflue.com	ICC - Industrial Chimney Co. www.icc-rsf.com
Security Chimneys International Ltd. www.securitychimneys.com	Z-FLEX US Inc. NovaFlex Group www.novaflex.com
ProTech Systems, Inc. www.protechinfo.com	M&G / Duravent www.duravent.com

IMPORTANT

For exhaust vent pipe material:
Do not use any other vent material.
Do not use galvanized pipe, plastic pipe and/or chimney liners (rigid or flexible) of any kind.

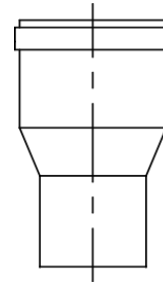

Increaser (min. stainless steel pipe diameter is 3 in. (76 mm))

Supplier	Boiler Model	PP(s) increaser (60 to 80 mm) (see illustration above)	CVPC Starter Adaptor for air intake 2 in.	Quantity
Viessmann	B1HA 26, 35, 94, 125 B1KA 35, 125 B2TB 19, 35, 68, 125 B2HA 19, 28, 35 B2HB 19, 26, 35, 68, 94, 125			1

Vent Requirements - Stainless Steel *(continued)*

⚠ WARNING

(For this type of installation only:) Boiler comes with pre-installed combustion air cover mounted on the concentric vent pipe adaptor. Do not remove combustion air intake cover. Removing this cover may cause unintended room air dependent operation (non-direct vent). Room air dependent operation requires provision of combustion and ventilation air (as per section "Single Pipe Venting", page 59).

Vent pipe starter adaptors for B1HA 26, 35, 94, 125, B1KA 35, 125, B2HA 19, 28, 35, B2HB 19, 26, 35, 68, 94, 125, B2TB 26, 35, 94, 125

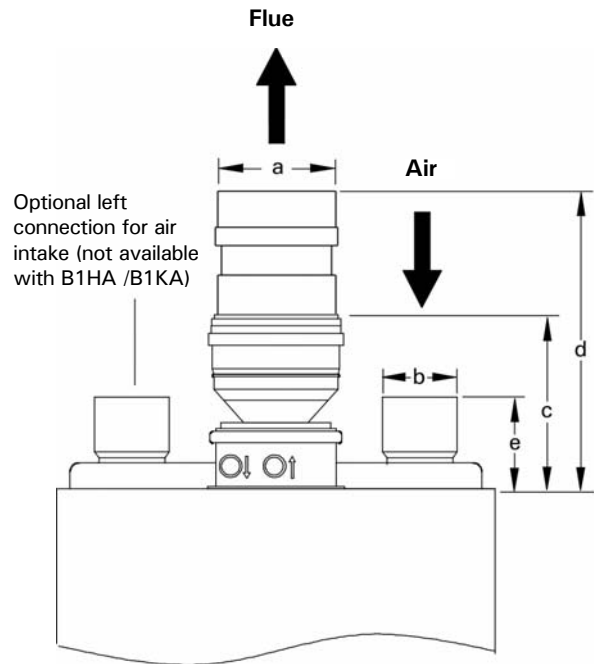
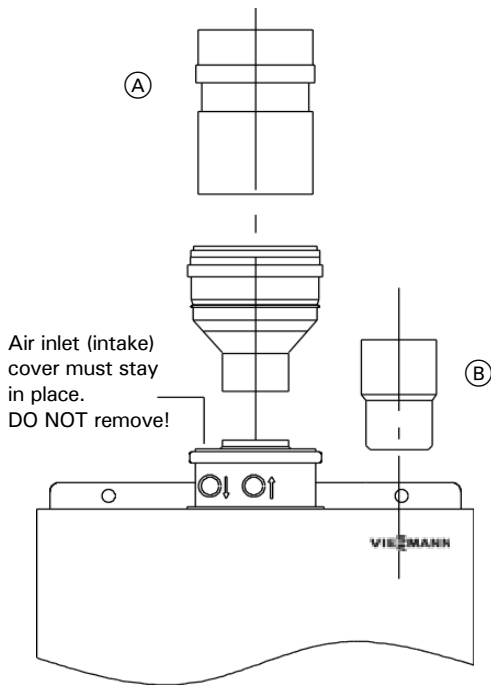

Legend

- Ⓐ Stainless steel slip joint vent starter adaptor
- Ⓑ 2 in. CVPC starter adaptor
- a 3 in. (76 mm)
- b 2 in. (51 mm)
- c 6.25 in. (159 mm)
- d 10.34 in. (263 mm)
- e 3 in. (76 mm)

Vent Requirements - Stainless Steel *(continued)*

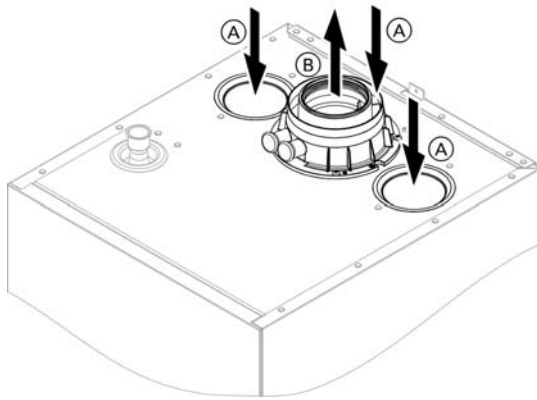

Legend

- (A) Combustion air
- (B) Flue gas

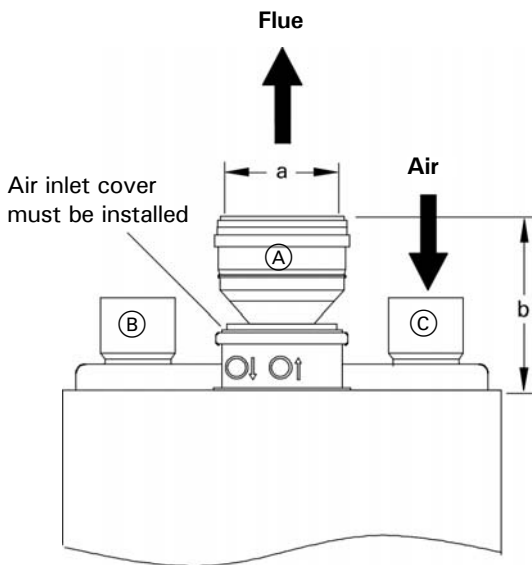

Legend

- (A) Stainless steel slip joint vent starter adaptor
- (B) 3 in. (80 mm) PPs combustion air piping
- (C) 3 in. CVPC/ABS/PVC combustion air piping
- a 3 in. (76 mm)
- b 6.25 in. (159 mm)

WARNING

The boiler comes with an accessory combustion air cover for the concentric vent pipe adaptor. For direct vent two pipe systems this cover must be installed. Failure to install this cover may result in unintended room air dependent operation (non-direct vent). Room air dependent operation requires provisions of combustion and ventilation air (as per section 'Single Pipe Venting' on page 59).

Vent pipe starter adaptors for;
 B1HE 85, 120, 150, 199
 B1KE 120, 199
 B2HE 85, 120, 150, 199

IMPORTANT

The combustion air gaskets located at the sides of the coaxial vent pipe adaptor are designed to accept combustion air directly without the need for a starter adaptor. These gaskets are not the same size. Only remove the center portion of the gasket required for the combustion air pipe material being used. If necessary the position of the gasket can be switched on the boiler from left to right or vice versa. In factory position PPs connection gasket is installed on the left, CVPC/ABS/PVC installed on the right.

Vent Requirements - Stainless Steel *(continued)*

Additional requirements for stainless steel vent pipe material *(continued)*

Parallel adaptor for two-pipe system

Supplier	Boiler Model	Ø in. (mm)	Quantity
Viessmann	B2HA 45, 60 B2HB 45, 57, 160, 199	3 (76) (See 'a' in illustration below)	1
	B2HA 80, 88, 100, 112, 150, 285, 311, 352, 399, 530	4 (102) (See 'a' in illustration below)	1

Parallel vent pipe starter adaptors for:
B2HA 45, 60, B2HB 45, 57, 199, 285

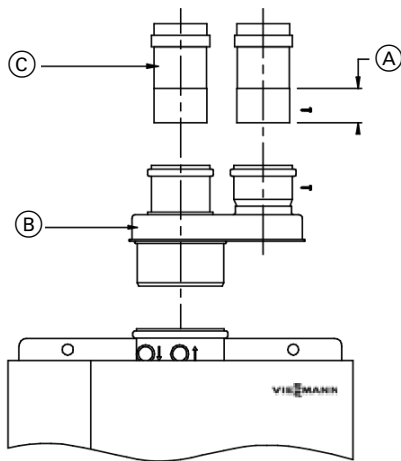

Legend

- (A) Air intake, max. insertion 2 ½ in. (64 mm) (use sheet metal screws to hold in place)
- (B) Viessmann parallel adaptor
- (C) Stainless steel slip joint vent starter adaptor

Parallel vent pipe starter adaptors for:
B2HA 80, 88, 100, 112, 150, 285, 311, 352, 399, 530

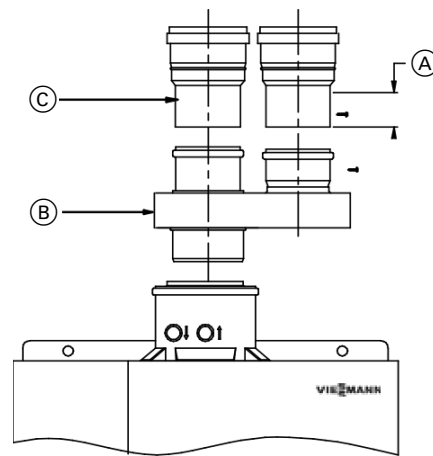

Legend

- (A) Air intake, max. insertion 2 ½ in. (64 mm) (use sheet metal screws to hold in place)
- (B) Viessmann parallel adaptor
- (C) Stainless steel slip joint vent starter adaptor

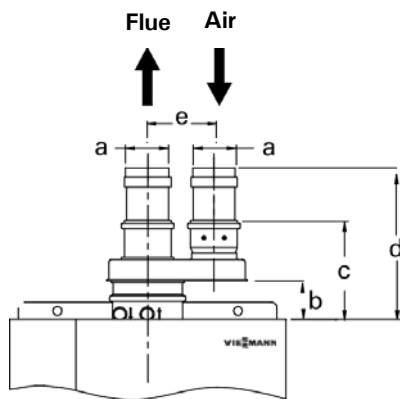

- a 3 in. (76 mm)
- b 2 ¾ in. (70 mm)
- c 7 in. (178 mm)
- d approx. 10 ¾ in. (271 mm)
- e 4 ¾ in. (120 mm)

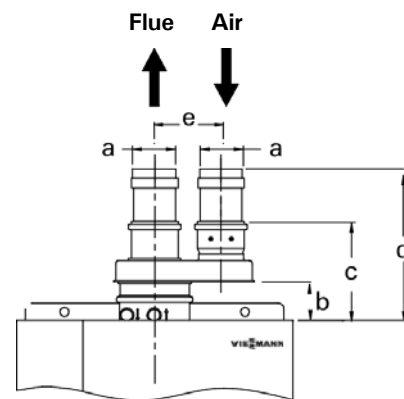

- a 4 in. (100 mm)
- b 5 ½ in. (130 mm)
- c 9 ¾ in. (237 mm)
- d 12 7/16 in. (327 mm)
- e 5 ½ in. (140 mm)

Vent Requirements - Stainless Steel *(continued)*

Additional requirements for stainless steel vent pipe material *(continued)*

Exhaust vent termination options (vertical installation)

Supplier	Boiler Model	Stainless Steel Slip Joint Starter Adaptor	Vertical Termination Coupling with Screen
Flexmaster / Z-Flex	B1HA 26, 35, 94, 125, B1KA 35, 125	3 in. 2SVSVB23S	3 in. 2SVSTP(F,X)03
	B2TA 19, 35, B2TB 19, 35, 68, 125	3 in. 2SVSVB23S	3 in. 2SVSTP(F,X)03
	B2HA 19, 28, 35, B2HB 19, 26, 35, 68, 94, 125	3 in. 2SVSVB23S	3 in. 2SVSTP(F,X)03
	B2HA 45, 60, B2HB 45, 57, 160, 199	3 in. 2SVSVB23S	3 in. 2SVSTP(F,X)03
	B2HA 80, 88, 100, 112, 150, 285, 311, 352, 399, 530, B1HE 85, 120, 150, 199, B1KE 120, 199, B2HE 85, 120, 150, 199	4 in. 2SVSVB24S 3 in. 2SVSVB23S 3 in. 2SVSVB23S	4 in. 2SVSTP(F,X)04 3 in. 2SVSTP(F,X)03 3 in. 2SVSTP(F,X)03
Heat-Fab	B1HA 26, 35, 94, 125, B1KA 35, 125	3 in. 9301VSMN	3 in. 9392
	B2TB 19, 35, 68, 125, B2HA 19, 28, 35	3 in. 9301VSMN	3 in. 9392
	B2HB 19, 26, 35, 68, 94, 125	3 in. 9301VSMN	3 in. 9392
	B2HA 45, 60, B2HB 45, 57, 199, 285	3 in. 9301VSMN	3 in. 9392
	B2HA 80, 88, 100, 112, 150, 285, 311, 352, 399, 530, B1HE 85, 120, 150, 199, B1KE 120, 199, B2HE 85, 120, 150, 199	4 in. 9401VSMN 3 in. 9301VSMN 3 in. 9301VSMN	4 in. 9492 3 in. 9392 3 in. 9392
ProTech	B1HA 26, 35, 94, 125, B1KA 35, 125	3 in. 300568	3 in. 300186
	B2TB 19, 35, 68, 125, B2HA 19, 28, 35	3 in. 300568	3 in. 300186
	B2HB 19, 26, 35, 68, 94, 125	3 in. 300568	3 in. 300186
	B2HA 45, 60, B2HB 45, 57, 160, 199	3 in. 300568	3 in. 300186
	B2HA 80, 88, 100, 112, 150, 285, 311, 352, 399, 530, B1HE 85, 120, 150, 199, B1KE 120, 199, B2HE 85, 120, 150, 199	4 in. 300569 3 in. 300568 3 in. 300568	4 in. 300187 3 in. 300186 3 in. 300186
Security Chimneys	B1HA 26, 35, 94, 125, B1KA 35, 125	3 in. CTX-V3	Contact supplier
	B2HA 19, 28, 35	3 in. CTX-V3	
	B2TB 19, 35, 68, 125, B2HB 19, 28, 35, 68, 94, 125	3 in. CTX-V3	
	B2HA 45, 60, B2HB 45, 57, 160, 199	3 in. CTX-V3	
	B2HA 80, 88, 100, 112, 150, 285, 311, 352, 399, 530, B1HE 85, 120, 150, 199, B1KE 120, 199, B2HE 85, 120, 150, 199	4 in. CTX-V4 3 in. CTX-V3 3 in. CTX-V3	

Other exhaust vent termination options (horizontal installation)

Supplier	Boiler Model	Termination Elbow with Screen 90° or 45°	Termination Tee with Screen	Termination Hood with Screen
Flexmaster	B1HA 26, 35, 94, 125, B1KA 35, 125	Contact supplier	Contact supplier	Contact supplier
	B2TB 19, 35, 68, 125			
	B2HA 19, 28, 35, B2HB 19, 26, 35, 68, 94, 125			
	B2HA 45, 60, WB2B 80, 105			
	B2HB 45, 57, 160, 199, B2HA 80, 88, 100, 112, 150, 285, 311, 352, 399, 530, B1HE 85, 120, 150, 199, B1KE 120, 199, B2HE 85, 120, 150, 199			
Heat-Fab	B1HA 26, 35, 94, 125, B1KA 35, 125	Contact supplier	Contact supplier	Contact supplier
	B2TB 19, 35, 68, 125			
	B2HA 19, 28, 35, B2HB 19, 26, 35, 68, 94, 125			
	B2HA 45, 60, B2HB 45, 57, 160, 199, B2HA 80, 88, 100, 112, 150, 285, 311, 352, 399, 530,			
	B1HE 85, 120, 150, 199, B1KE 120, 199, B2HE 85, 120, 150, 199			
ProTech	B1HA 26, 35, 94, 125, B1KA 35,	Contact supplier	Contact supplier	Contact supplier
	B2TB 19, 35, 68, 125 B2HA 19, 28, 35,			
	B2HB 19, 26, 35, 68, 94, 125			
	B2HA 45, 60, B2HB 45, 57, 160, 199,			
	B2HA 80, 88, 100, 112, 150, 285, 311, 352, 399, 530, B1HE 85, 120, 150, 199, B1KE 120, 199, B2HE 85, 120, 150, 199			

These tables reflect the parts required if using special venting system for both exhaust vent and air intake pipe system. If using ABS/PVC/CPVC material for combustion air intake pipe, (refer to page 43 or proper starter adaptor for the system).

Vent Requirements - Stainless Steel *(continued)*

Maximum equivalent length Vitodens 100-W / 200-W / 222-F (horizontally or vertically vented)

Boiler model		Stainless Steel Vent Diameter		
		3 in.	4 in.	5 in.
B1HA 26, 35, 94, 125 B1KA 35, 125	ft.(m)	164 (50)	200 (61)	--
B1HE 85,120	ft.(m)	164 (50)	198 (60)	--
B1HE 150, 199	ft.(m)	98 (30)	148 (45)	--
B1KE 120	ft.(m)	164 (50)	198 (60)	--
B1KE 199	ft.(m)	98 (30)	148 (45)	--
B2TB 19, 35, 68, 125	ft.(m)	148 (45)	180 (55)	--
B2HA 19, 28, 35, B2HB 19, 26, 35, 68, 94, 125				
B2HA 45, 60, B2HB 45, 57, 160, 199	ft.(m)	98 (30)	148 (45)	--
B2HA 80, 88, 100, 112, 285, 311, 352, 399	ft.(m)	--	131 (40)	--
B2HA 150, 530	ft.(m)	--	131 (40)* ¹	131 (40)* ²
B2HE 85, 120	ft.(m)	164 (50)	198 (60)	--
B2HE 150, 199	ft.(m)	98 (30)	148 (45)	--

Note: For combination of different vent/air intake pipe diameters, such as Ø 3 in. stainless steel vent with Ø 2 in. (CVPC, PVC, ABS) air intake pipe, the total equivalent length must be used for the smaller pipe diameter. See tables starting on page 47.

- *¹ There is an input reduction of 9% for model B2HA 150, 530 when a 4 in. diameter vent and air intake pipe are used.
- *² 4 in. to 5 in. increaser field supplied

Component Parts of the Venting System - Stainless Steel

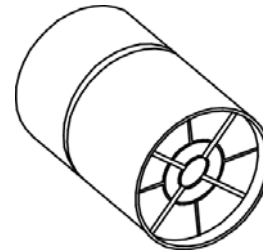
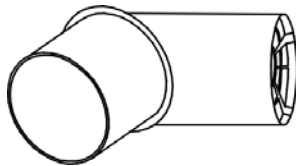

Termination Coupling with Screen

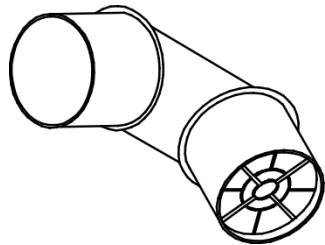

Termination Tee with Screen 90° or 45°

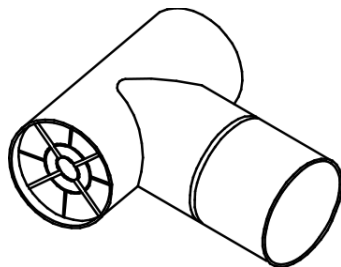
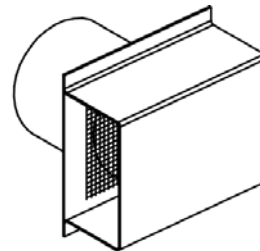

Termination Tee with Screen

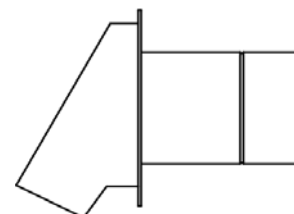

Termination Hood with Screen

Vent Requirements - CPVC

Additional requirements for UL/ULC listed CPVC vent pipe material

See table below and contact Viessmann to order special parts, use CPVC classified as type BH class IIB 90°C vent.

Prior to installation, check that the correct single-pipe vent parts were ordered and supplied.

See table below for special starter adaptor and bird screen models required for your installation. In case of discrepancies, contact Viessmann.

Exhaust vent/air intake connection to boiler

The vent connection to the Vitodens boiler must be made with the CPVC starter adaptor and/or parallel adaptor (see table below). The starter adaptors are intended for a slip fit and slide into the parallel adaptor with a gentle twisting motion.

For vent/air intake pipe system, two wire mesh screens (bird screen) must be ordered from Viessmann. These parts are available in pre-cut diameters of 2 in., 3 in. and 4 in. (see table below).

Note: The Vitodens boiler has passed the zero inches vent clearance to combustibles testing requirements dictated by the Harmonized Standard ANSI Z21.13. CSA 4.9. and therefore is listed for zero clearance to combustibles when vented with a single pipe special venting system (CPVC material). The zero inches vent clearance to combustibles for the Vitodens boiler supersedes the clearance to combustibles listing that appears on the special venting system marking label.

IMPORTANT

For exhaust vent pipe material:

Do not use any other vent material.

Do not use galvanized pipe, plastic pipe and/or chimney liners (rigid or flexible) of any kind.

Required starter adaptors for CPVC system

Part	Boiler Model	Diameter	Supplier	Quantity
Parallel Pipe Adaptor	B2HA 45, 60, B2HB 45, 57, 160, 199	3 in.	Viessmann	1
	B2HA 80, 88, 100, 112, 150, 285, 311, 352, 399, 530	4 in.		1
CPVC Starter Adaptor	B2TB 19, 35, B1HA 26, 35, 94, 125, B1KA 35, 125	2 in. *1	Viessmann	2
	B2HA 19, 28, 35			2
	B2HB 19, 26, 35, 68, 94, 125, B2HA 45, 60	3 in. *2		2
	B2HB 45, 57, 160, 199	4 in. *3		2
	B2HA 80, 88, 100, 112, 150, 285, 311, 352, 399, 530 B1HE 85, 120, 150, 199, B1KE 120, 199 B2HE 85, 120, 150, 199	3 in. *2		1
Wire Mesh Screen for Termination Elbows/Coupling	B2TB 19, 35, 68, 125	2 in.	Viessmann	2
	B1HA 26, 35, 94, 125, B1KA 35, 125	3 in. (if used)		2
	B2HA 19, 28, 35, B2HB 19, 26, 35, 68, 94, 125	4 in. (if used)		2
	B2HA 45, 60, B2HB 45, 57, 160, 199	3 in.		2
	B2HA 80, 88, 100, 112, 150, 285, 311, 352, 399, 530	4 in.		2
	B1HE 85, 120, 150, 199, B1KE 120, 199			
	B2HE 85, 120, 150, 199	3 in.		2

*1 See page 44

*2 See page 45

*3 See page 45

Requirements for Rigid PP(s) Vent Pipe Material

IMPORTANT

When replacing parts (use manufacturer’s original replacement parts).

The venting system must be installed by a licensed professional heating contractor familiar with the operation and maintenance of heating boilers and venting. Before installing this product, ensure that the complete installation literature has been read. Failure to follow proper installation procedures as stated in these instructions, including vent pitch and proper boiler connections, may violate local, provincial/state, or national codes and cause unsafe conditions which may lead to severe property damage or personal injury.

Prior to installation, check that the correct single-pipe vent parts were ordered and supplied.

The venting system must be installed in accordance with local building code requirements as well as national codes. For installations in Canada use CAN/CSA-B149.1 Natural Gas Installation Code or CAN/CSA-B149.2 Propane Installation Code as applicable; in the U.S. use the National Fuel Gas Code ANSI Z223.1 or NFPA Standard 54. Always use latest edition of applicable standard.

To ensure safe operation of the boiler, Viessmann recommends that the system be inspected once a year by a qualified service technician.

Every venting system must be planned and installed for optimum performance and safety. These Installation Instructions are designed to help you determine venting requirements and limitations with respect to installation. Please read and follow these instructions carefully.

It is the responsibility of the installer to contact local building and fire officials concerning any installation restrictions and/or inspection requirements that may apply. Permits may be required before commencement of the installation.

Vent system manufacturers

The following Coaxial and PP(s) vent system manufacturers may be contacted for assistance in designing the appropriate venting system for Vitodens 100 and Vitodens 200 boilers.

These manufacturers deliver PP(s) concentric rigid and flexible vents in three sizes.

M&G/Duravent, PolyFlue	Centrotherm InnoFlue, Z-Flex, ECCO
2 - 4 in. (60 - 100 mm)	2 in. (60 mm)
3 - 5 in. (80 - 125 mm)	3 in. (80 mm)
4 - 6 in. (100 - 150 mm)	4.3 - 6.3 in. (110 - 160 mm)

For Vitodens B2HA 80-150, 285-530 the vent manufacturers developed special transition adaptors. The air intake termination for side wall air intake installations should be located on a wall that is least affected by prevailing winds. High winds may affect boiler operation.

For parts and system design contact:

M&G / Duravent www.duravent.com	Centrotherm InnoFlue www.centrotherm.us.com
PolyFlue - Selkirk www.polyflue.com	ECCO Manufacturing www.eccomfg.com
Z-FLEX US Inc. NovaFlex Group www.novaflex.com	

Because of its sealed combustion chamber, the Vitodens gas-fired condensing boiler is suitable for operation with balanced flue.

The Vitodens boiler, flue gas adaptor and parallel adaptor (if used) are approved together under CSA 4.9. ANSI Z21.13 Standard.

IMPORTANT

DO NOT mix pipe, fittings, or joining methods from different vent system manufacturers.
DO NOT use adhesives of any kind with this venting system.

The vent length requirements stated starting on page 47 in this manual must be observed.

Flue gases are discharged via rigid PP(s) vent components to the outdoors. This vent system is constructed from flame-retardant plastic [polypropylene rated for a maximum temperature of 230°F (110°C)].

Vent and Air Intake Pipe Starter Adaptors - PP(s)

Vent pipe starter adaptors for B1HA 26, 35, 94, 125, B1KA 35, 125, B2TB 19, 35, 68, 125, B2HA 19, 28, 35 and B2HB 19, 26, 35, 68, 94, 125

Vent starter adaptor is not required if using PP(s) system.

Air intake cover must stay in place. DO NOT remove!

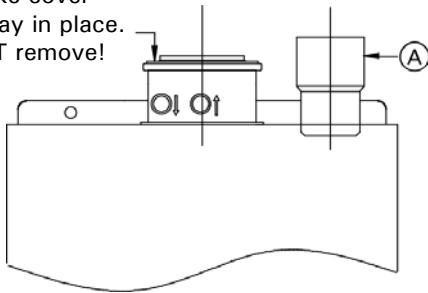

When using PP(s) material for combustion air supply pipes, CPVC adaptors are not required.

! WARNING

(For this type of installation only:)

Boiler comes with pre-installed combustion air cover mounted on the concentric vent pipe adaptor. Do not remove combustion air intake cover. Removing this cover may cause unintended room air dependent operation (non-direct vent). Room air dependent operation requires provision of combustion and ventilation air (as per section "Single Pipe Venting", page 59).

Legend

- Ⓐ Air intake starter adaptor, for PVC, CPVC and ABS only - 60 mm to 2 in. (if using PP(s) for air intake system, an adaptor is not required).

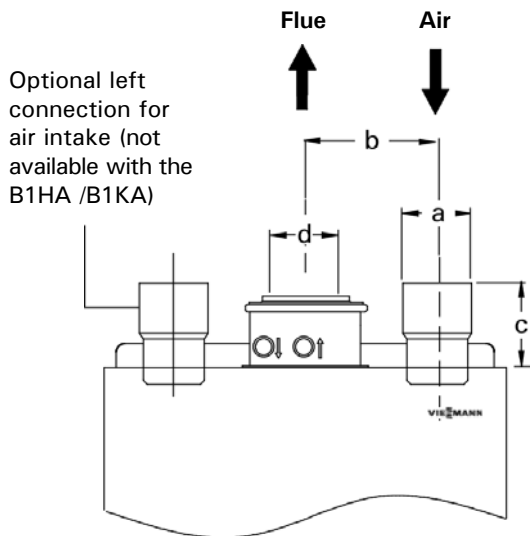

Legend

- a 2 in. (51 mm)
- b 4 ¾ in. (120 mm)
- c 3 in. (76 mm)
- d 60 mm

Vent Pipe and Air Intake Starter Adaptors - PP(s) (continued)

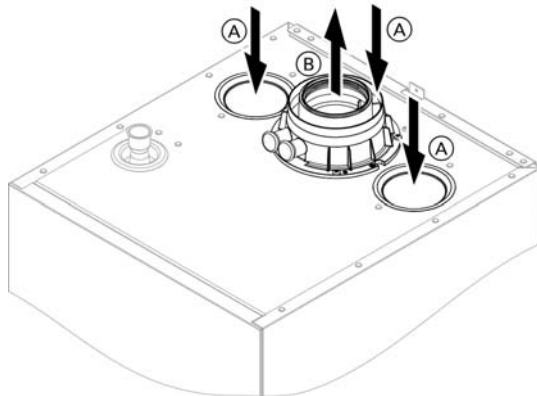

Legend

- (A) Combustion air
- (B) Flue gas

WARNING

The boiler comes with an accessory combustion air cover for the concentric vent pipe adaptor. For direct vent two pipe systems this cover must be installed. Failure to install this cover may result in unintended room air dependent operation (non-direct vent). Room air dependent operation requires provisions of combustion and ventilation air (as per section 'Single Pipe Venting' on page 58).

Vent pipe starter adaptors for;
 B1HE 85, 120, 150, 199
 B1KE 120, 199
 B2HE 85, 120, 150, 199

IMPORTANT

The combustion air gaskets located at the sides of the coaxial vent pipe adaptor are designed to accept combustion air directly without the need for a starter adaptor. These gaskets are not the same size. Only remove the center portion of the gasket required for the combustion air pipe material being used. If necessary the position of the gasket can be switched on the boiler from left to right or vice versa. In factory position PPs connection gasket is installed on the left, CVPC/ABS/PVC installed on the right.

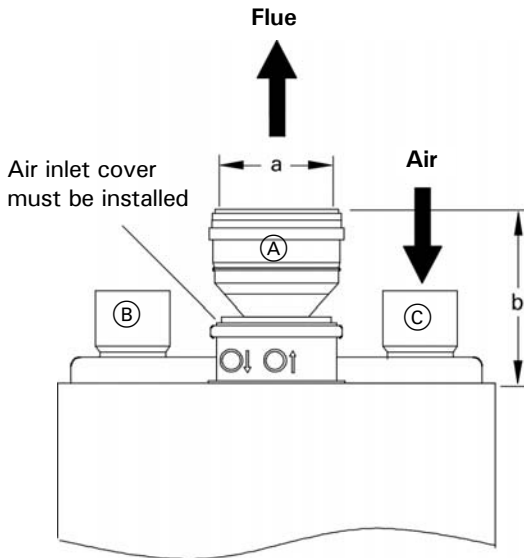

Legend

- (A) 3 in. (80 mm) PP(s) venting system component
- (B) 3 in. (80 mm) PP(s) combustion air piping
- (C) 3 in. CPVC/ABS/PVC combustion air piping
- a 3 in. (76 mm)
- b 80 mm

Vent Pipe and Air Intake Starter Adaptors - PP(s) *(continued)*

Parallel vent pipe starter adaptors for B2HA 45, 60, B2HB 45, 57, 160, 199

Parallel vent pipe starter adaptors for B2HA 80, 88, 100, 112, 150, 285, 311, 352, 399, 530

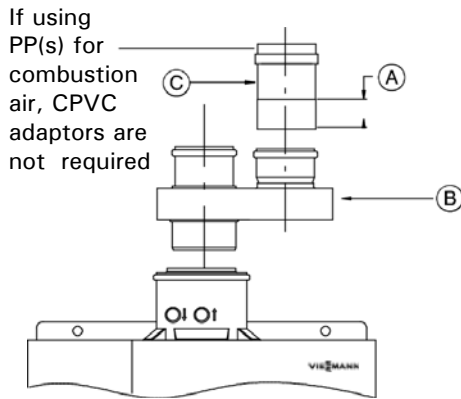

Legend

- Ⓐ Air intake, max. insertion 2½ in. (64 mm)
- Ⓑ Viessmann parallel adaptor or Centrotherm parallel adaptor
- Ⓒ Air intake starter adaptor for PVC, CPVC and ABS only. 80 mm to 3 in. (if using PP(s) for combustion air intake system, an adaptor is not required).

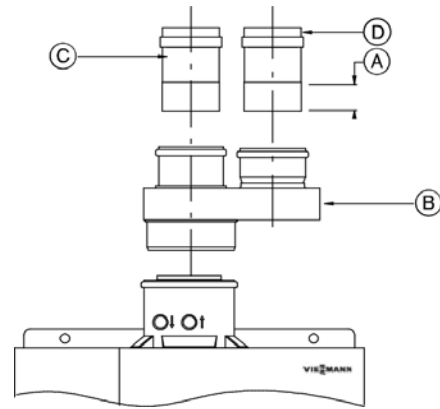

Legend

- Ⓐ Air intake, max. insertion 2½ in. (64 mm)
- Ⓑ Viessmann parallel adaptor
- Ⓒ PP(s) slip joint transition adaptor (110 mm to 100 mm) only required if M&G system is used
- Ⓓ Air intake starter adaptor for PVC, CPVC and ABS, when using PP(s) system 110 mm to 100 mm, a transition adaptor is required.

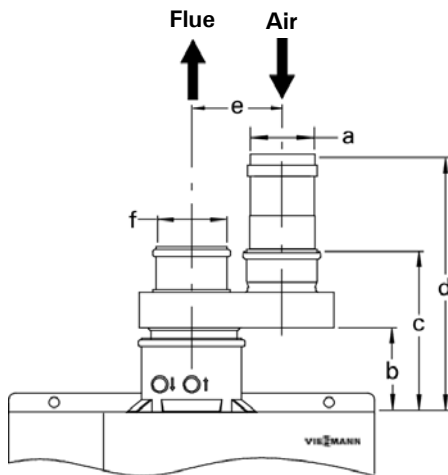

Legend

- a 3 in. (76 mm)
- b 2¾ in. (70 mm)
- c 7 in. (178 mm)
- d approx. 10¾ in. (271 mm)
- e 4¾ in. (120 mm)
- f 80 mm *

* For exhaust system Ø of 4 in. (100 mm), an increaser adaptor 3 in. to 4 in. (80 mm to 100 mm) must be used.

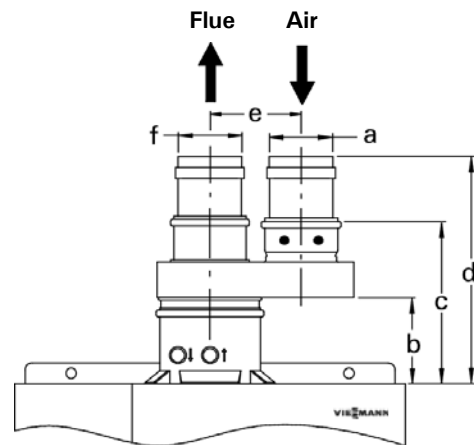

Legend

- a 4 in. (100 mm)
- b 5½ in. (130 mm)
- c 9¾ in. (237 mm)
- d approx. 12⅞ in. (327 mm)
- e 5½ in. (140 mm)
- f 100 mm

Parallel adaptor for two-pipe system

Supplier	Boiler Model	Ø in. (mm)	Quantity
Viessmann	B2HA 45, 60, B2HB 45, 57, 160, 199	3 (80)	1
	B2HA 80, 88, 100, 112, 150, 285, 311, 352, 399, 530	4 (110)	1

Side Wall Vent Termination - Stainless Steel, CPVC or PP(s)

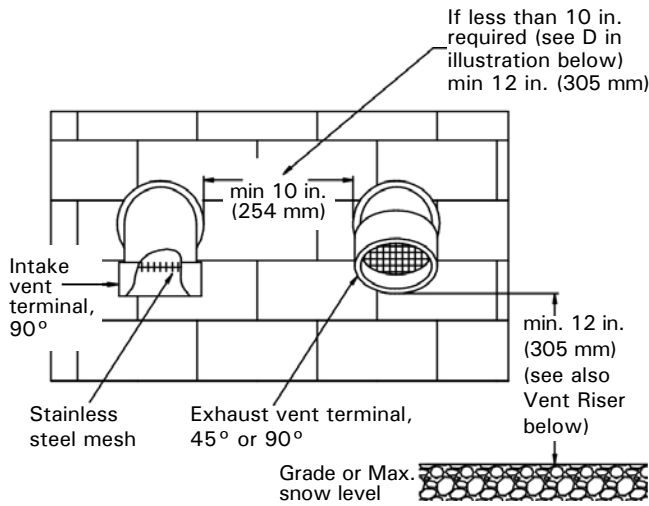

Side wall vent termination (front view)

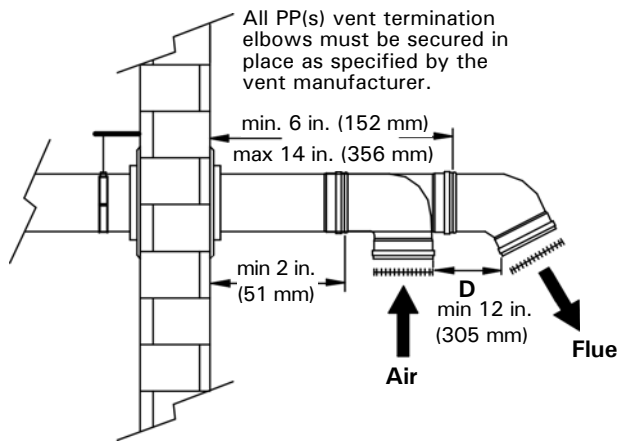

Side wall vent termination (side view)

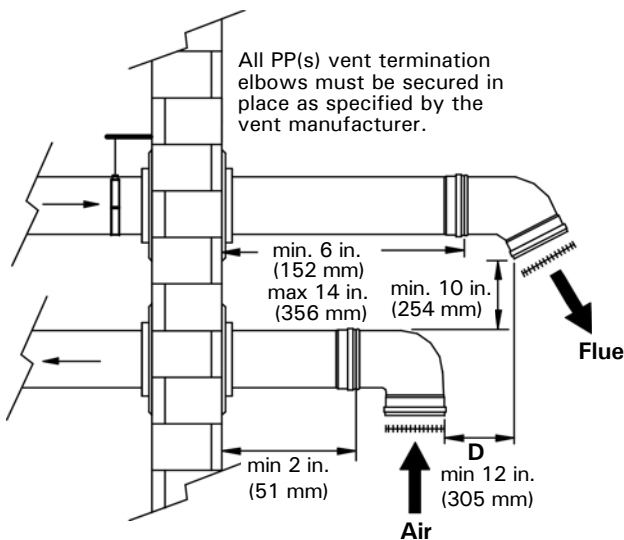

Side wall vent termination (side view)

IMPORTANT

The exhaust vent/air intake system must terminate so that proper clearances are maintained as cited in local codes or the latest edition of the "Natural Gas and Propane Installation Code" CAN/CSA-B149.1 (Canada), or the "National Fuel Gas Code" ANSI Z223.1 (NFPA 54) (U.S.A.). See page 9.

WARNING

Vent termination must be at least 12 in. (300 mm) above the anticipated snow level (consult your local building authorities or local weather office). Locate vent termination in such a way that it cannot be blocked by snow.

IMPORTANT

For PP(s) systems, all exhaust vent and air intake piping and elbows exposed outside, must be UV resistant polypropylene (supplied by the vent manufacturer).

Note: Use of the combustion intake screen is optional.

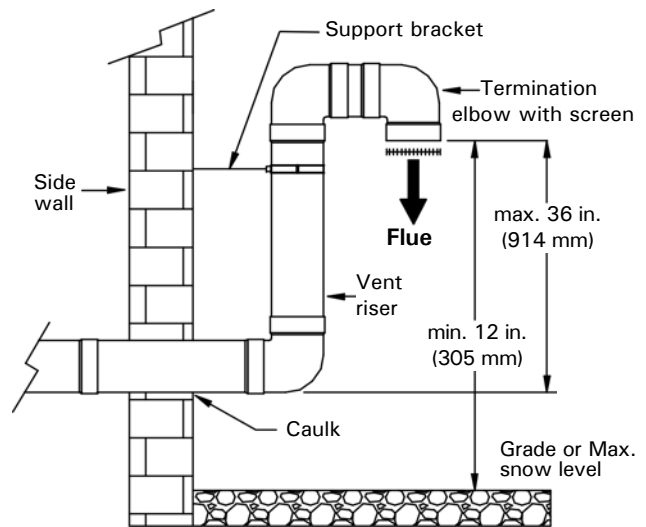

Installation of field fabricated vent riser

Vent Length Requirements

Maximum vent/air intake pipe length - horizontal

IMPORTANT

Always include vent termination length in calculations.

The total equivalent length specified for a two pipe system is the total **combined** length of the exhaust vent and air intake pipe system.

Do not exceed these maximum lengths.

See table and illustration below for reference.

All PP(s) vent material and air intake (if PP(s) used) must be ULC S636 or UL1738 listed, manufactured by M&G / DuraVent or Centrotherm.

Maximum allowable equivalent length - horizontal

Boiler Model	System Ø See note below	Max. combined equivalent vent length (a + b)* ²
B1HA 26, 35, 94, 125, B1KA 35, 125	2 in. (51 mm) 3 in. (76 mm)* ¹ 4 in. (102 mm)* ¹	98 ft. (30 m) 164 ft. (50 m) 200 ft. (61 m)
B1HE 85	2 in. (51 mm)* ⁵ 3 in. (76 mm) 4 in. (102 mm)* ¹	98 ft. (30 m)* ⁶ 164 ft. (50 m) 198 ft. (60 m)
B1HE 120	2 in. (51 mm)* ⁵ 3 in. (76 mm) 4 in. (102 mm)* ¹	98 ft. (30 m)* ⁷ 164 ft. (50 m) 198 ft. (60 m)
B1HE 150, 199	3 in. (76 mm) 4 in. (102 mm)* ¹	98 ft. (30 m) 148 ft. (45 m)
B1KE 120	2 in. (51 mm)* ⁵ 3 in. (76 mm) 4 in. (102 mm)* ¹	98 ft. (30 m)* ⁷ 164 ft. (50 m) 198 ft. (60 m)
B1KE 199	3 in. (76 mm) 4 in. (102 mm)* ¹	98 ft. (30 m) 148 ft. (45 m)
B2HA 19, 28, 35, B2HB 19, 26, 35, 68, 94, 125 B2TB 19, 35, 68, 125	2 in. (51 mm) 3 in. (76 mm)* ¹ 4 in. (102 mm)* ¹	115 ft. (35 m) 148 ft. (45 m) 180 ft. (55 m)
B2HA 45, 60, B2HB 45, 57, 160, 199	3 in. (76 mm) 4 in. (102 mm)* ¹	98 ft. (30 m) 148 ft. (45 m)
B2HA 80, 88, 100, 112, 285, 311, 352, 399 B2HA 150, 530	4 in. (102 mm) 4 in. (100 mm)* ³ 5 in. (125 mm)* ⁴	131 ft. (40 m) 131 ft. (40 m) 131 ft. (40 m)
B2HE 85	2 in. (51 mm)* ⁵ 3 in. (76 mm) 4 in. (102 mm)* ¹	98 ft. (30 m)* ⁶ 164 ft. (50 m) 198 ft. (60 m)
B2HE 120	2 in. (51 mm)* ⁵ 3 in. (76 mm) 4 in. (102 mm)* ¹	98 ft. (30 m)* ⁷ 164 ft. (50 m) 198 ft. (60 m)
B2HE 150, 199	3 in. (76 mm) 4 in. (102 mm)* ¹	98 ft. (30 m) 148 ft. (45 m)

*¹ 2 in. to 3 in., 3 in. to 4 in. or 2 in. to 4 in. increaser field supplied.

*² See illustrations below.

*³ Due to higher exhaust vent pipe resistance, there is an automatic input reduction of 9% for model B2HA 150/530 when a 4 inch diameter vent and air intake pipe are used.

*⁴ 4 in. to 5 in. increaser field supplied.

*⁵ 3 in. to 2 in. reducer required field supplied.

*⁶ There is an automatic input reduction of 2%.

*⁷ There is an automatic input reduction of 5%.

Note: For combination of different vent/air intake pipe diameters, such as Ø 3 in. stainless steel vent with Ø 2 in. (CVPC, PVC, ABS) air intake pipe, the total equivalent length must be used for the smaller pipe diameter.

Minimum vent length is 3.3 ft. (1 m).

Vent Length Requirements *(continued)*

Maximum vent/air intake pipe length - horizontal *(continued)*

First elbows not included in equivalent vent length calculation

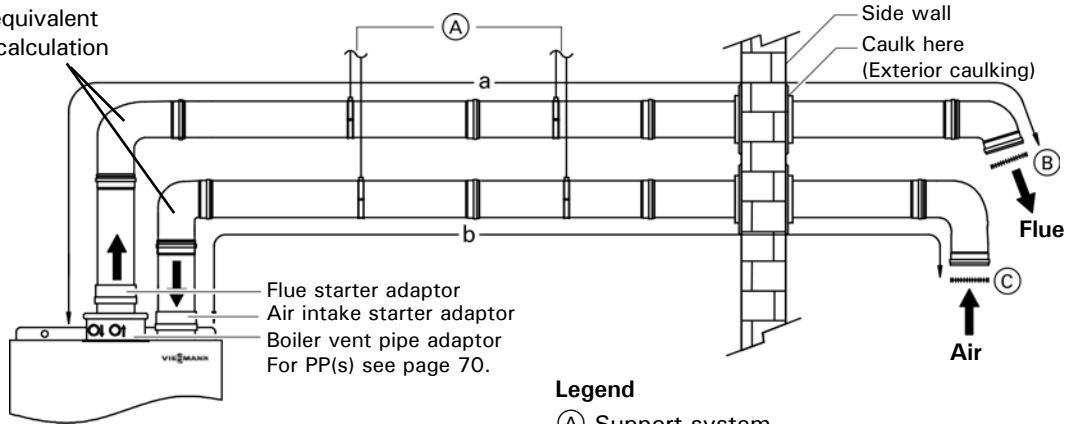

Vitodens 100-W B1HA 26, 35, 94, 125, B1KA 35,125, B1HE 85, 120, 150, 199, B1KE 120, 199, 222-F B2TB 19, 35, 68, 125, 200-W B2HA 19, 28, 35, B2HB 19, 26, 35, 68, 94, 125, B2HE 85, 120, 150, 199

Legend

- (A) Support system
- (B) Exhaust pipe termination with screen
- (C) Combustion air intake with screen (use of the combustion intake screen is optional).
- a Equivalent vent length (exhaust)
- b Equivalent vent length (air intake)

IMPORTANT

For PP(s) systems, all exhaust vent and air intake piping and elbows exposed outside, must be UV resistant polypropylene (supplied by the vent manufacturer).

IMPORTANT

First elbow not included in equivalent vent calculation. Always include vent termination length in calculations.

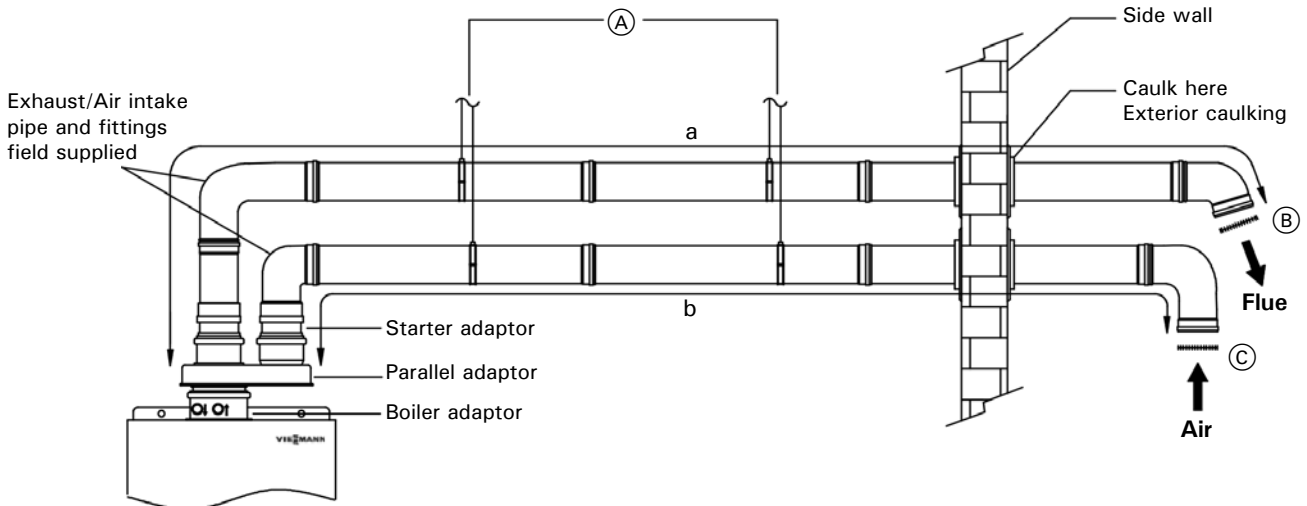

Vitodens 200-W B2HA 45, 60, 80, 88, 100, 112, 150, 285, 311, 352, 399, 530, B2HB 45, 57, 160, 199

Legend

- (A) Support system
- (B) Exhaust pipe termination with screen
- (C) Combustion air intake with screen (use of the combustion intake screen is optional).
- a Equivalent vent length (exhaust)
- b Equivalent vent length (air intake)

IMPORTANT

First elbow not included in equivalent vent calculation. Always include vent termination length in calculations.

IMPORTANT

For PP(s) systems, all exhaust vent and air intake piping and elbows exposed outside, must be UV resistant polypropylene (supplied by the vent manufacturer).

Vent Length Requirements *(continued)***Maximum vent/air intake pipe length - vertical**

The total equivalent length specified for a two pipe system is the total **combined** length of the exhaust vent and air intake pipe system. Do not exceed these maximum lengths. See table below as well as illustrations above for reference. All PP(s) vent material and air intake (if PP(s) used) must be ULC S636 listed, manufactured by M&G / DuraVent.

Maximum allowable equivalent length - vertical

Boiler Model	System Ø See note below	Max. combined equivalent vent length (a + b)* ²
B1HA 26, 35, 94, 125, B1KA 35, 125	2 in. (51 mm) 3 in. (76 mm)* ¹ 4 in. (102 mm)* ¹	86 ft. (31 m) 164 ft. (50 m) 200 ft. (61 m)
B1HE 85	2 in. (51 mm)* ⁵ 3 in. (76 mm) 4 in. (102 mm)* ¹	98 ft. (30 m)* ⁶ 164 ft. (50 m) 198 ft. (60 m)
B1HE 120	2 in. (51 mm)* ⁵ 3 in. (76 mm) 4 in. (102 mm)* ¹	98 ft. (30 m)* ⁷ 164 ft. (50 m) 198 ft. (60 m)
B1HE 150, 199	3 in. (76 mm) 4 in. (102 mm)* ¹	98 ft. (30 m) 148 ft. (45 m)
B1KE 120	2 in. (51 mm)* ⁵ 3 in. (76 mm) 4 in. (102 mm)* ¹	98 ft. (30 m)* ⁷ 164 ft. (50 m) 198 ft. (60 m)
B1KE 199	3 in. (76 mm) 4 in. (102 mm)* ¹	98 ft. (30 m) 148 ft. (45 m)
B2HA 19, 28, 35, B2HB 19, 26, 35, 68, 94, 125, B2TB 19, 35, 68, 125	2 in. (51 mm) 3 in. (76 mm)* ¹ 4 in. (102 mm)* ¹	115 ft. (35 m) 148 ft. (45 m) 180 ft. (55 m)
B2HA 45, 60, B2HB 45, 57, 160, 199	3 in. (76 mm) 4 in. (102 mm)* ¹	98 ft. (30 m) 148 ft. (45 m)
B2HA 80, 88, 100, 112, 285, 311, 352, 399	4 in. (102 mm)	131 ft. (40 m)
B2HA 150, 530	4 in. (100 mm)* ³ 5 in. (125 mm)* ⁴	131 ft. (40 m) 131 ft. (40 m)
B2HE 85	2 in. (51 mm)* ⁵ 3 in. (76 mm) 4 in. (102 mm)* ¹	98 ft. (30 m)* ⁶ 164 ft. (50 m) 198 ft. (60 m)
B2HE 120	2 in. (51 mm)* ⁵ 3 in. (76 mm) 4 in. (102 mm)* ¹	98 ft. (30 m)* ⁷ 164 ft. (50 m) 198 ft. (60 m)
B2HE 150, 199	3 in. (76 mm) 4 in. (102 mm)* ¹	98 ft. (30 m) 148 ft. (45 m)

*¹ 2 in. to 3 in., 3 in. to 4 in. or 2 in. to 4 in. increaser field supplied.

*² See illustration above

*³ Due to higher exhaust vent pipe resistance, there is an automatic input reduction of 9% for model B2HA 150, 530 when a 4 inch diameter vent and air intake pipe are used.

*⁴ 4 in. to 5 in. increaser field supplied.

*⁵ 3 in. to 2 in. reducer required field supplied.

*⁶ There is an automatic input reduction of 2%.

*⁷ There is an automatic input reduction of 5%.

Vent Length Requirements *(continued)*

Maximum vent/air intake pipe length - vertical *(continued)*

Note: For combination of different vent/air intake pipe diameters, such as Ø 3 in. stainless steel vent with Ø 2 in. (PP(s), CVPC, PVC, ABS) air intake pipe, the total equivalent length must be used for the smaller pipe diameter.

Minimum vent length is 3.3 ft. (1 m).

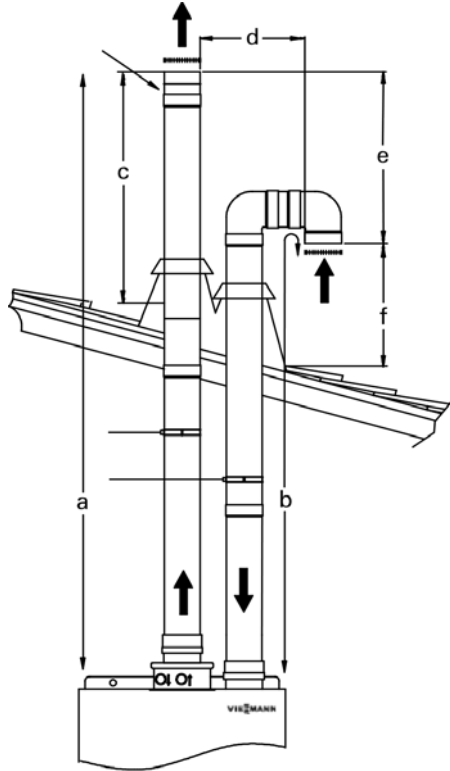

- Vertical Vent Installation:**
- Vitodens 100-W B1HA 26, 35, 94, 125
 - Vitodens 100-W B1KA 35, 125
 - Vitodens 222-F B2TB 19, 35, 68, 125
 - Vitodens 200-W B2HA 19, 28, 35
 - Vitodens 200-W B2HB 19, 26, 35, 68, 94, 125
 - Vitodens 100-W B1HE 85, 120, 150, 199
 - Vitodens 100-W B1KE 120, 199
 - Vitodens 200-W B2HE 85, 120, 150, 199

Legend

- a Equivalent length (exhaust)
- b Equivalent length (air intake)
- c min. 18 in. / max. 48 in.
- d min. 12 in.
- e min. 12 in.
- f 6 in. over max. local snow level (check with your local weather office for details)

IMPORTANT

All PP(s) vent termination elbows, must be secured in place as specified by manufacturer.

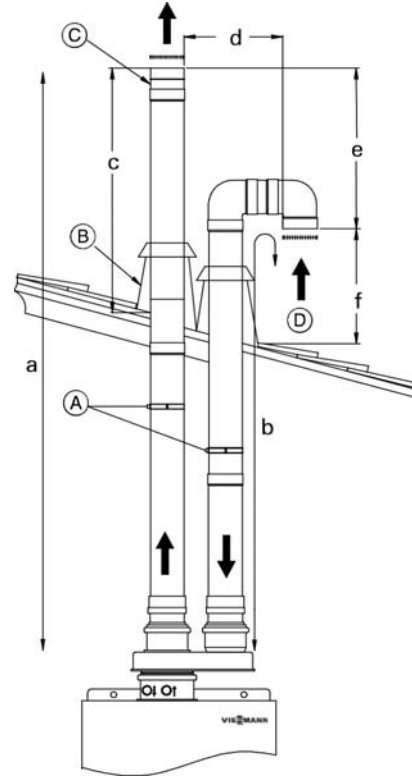

Vertical Vent Installation:

- Vitodens 200-W B2HA 45, 60, 80, 88, 100, 112, 150, 285, 311, 352, 399, 530
- Vitodens 200-W B2HB 45, 57, 160, 199

Legend

- (A) Support system
- (B) Flashings
- (C) Exhaust (straight coupling) with screen
- (D) Combustion air intake with screen (use of the combustion intake screen is optional).

IMPORTANT

For PP(s) systems, all exhaust vent and air intake piping and elbows exposed outside, must be UV resistant polypropylene (supplied by the vent manufacturer).

Vent Length Requirements *(continued)*

Maximum vent/air intake pipe length - horizontal/vertical (hybrid system)

All PP(s) vent material and air intake (if PP(s) used) must be ULC S636 or UL1738 listed, manufactured by M&G (Muelink & Grol b.v.) / DuraVent, or Centrotherm.

The total equivalent length specified for a two pipe system is the total **combined** length of the exhaust vent and air intake pipe system. Do not exceed these maximum lengths. See table and illustration below and illustration on page 52 for reference.

Maximum allowable equivalent length - vertical exhaust / horizontal air intake (hybrid)

Boiler Model	System Ø See note below	Max. combined equivalent vent length (a + b)* ²
B1HA 26, 35, 94, 125, B1KA 35, 125	2 in. (51 mm) 3 in. (76 mm)* ¹ 4 in. (102 mm)* ¹	98 ft. (30 m) 164 ft. (50 m) 200 ft. (61 m)
B1HE 85	2 in. (51 mm)* ⁵ 3 in. (76 mm) 4 in. (102 mm)* ¹	98 ft. (30 m)* ⁶ 164 ft. (50 m) 198 ft. (60 m)
B1HE 120	2 in. (51 mm)* ⁵ 3 in. (76 mm) 4 in. (102 mm)* ¹	98 ft. (30 m)* ⁷ 164 ft. (50 m) 198 ft. (60 m)
B1HE 150, 199	3 in. (76 mm) 4 in. (102 mm)* ¹	98 ft. (30 m) 148 ft. (45 m)
B1KE 120	2 in. (51 mm)* ⁵ 3 in. (76 mm) 4 in. (102 mm)* ¹	98 ft. (30 m)* ⁷ 164 ft. (50 m) 198 ft. (60 m)
B1KE 199	3 in. (76 mm) 4 in. (102 mm)* ¹	98 ft. (30 m) 148 ft. (45 m)
B2HA 19, 28, 35 B2HB 19, 26, 35, 68, 94, 125, B2TB 19, 35, 68, 125	2 in. (51 mm) 3 in. (76 mm)* ¹ 4 in. (102 mm)* ¹	115 ft. (35 m) 148 ft. (45 m) 180 ft. (55 m)
B2HA 45, 60, B2HB 45, 57, 160, 199	3 in. (76 mm) 4 in. (102 mm)* ¹	98 ft. (30 m) 148 ft. (45 m)
B2HA 80, 88, 100, 112, 285, 311, 352, 399	4 in. (102 mm)	131 ft. (40 m)
B2HA 150, 530	4 in. (100 mm)* ³ 5 in. (125 mm)* ⁴	131 ft. (40 m) 131 ft. (40 m)
B2HE 85	2 in. (51 mm)* ⁵ 3 in. (76 mm) 4 in. (102 mm)* ¹	98 ft. (30 m)* ⁶ 164 ft. (50 m) 198 ft. (60 m)
B2HE 120	2 in. (51 mm)* ⁵ 3 in. (76 mm) 4 in. (102 mm)* ¹	98 ft. (30 m)* ⁷ 164 ft. (50 m) 198 ft. (60 m)
B2HE 150, 199	3 in. (76 mm) 4 in. (102 mm)* ¹	98 ft. (30 m) 148 ft. (45 m)

- *¹ 2 in. to 3 in., 3 in. to 4 in. or 2 in. to 4 in. increaser (field supplied).
- *² See illustration below and on page 52
- *³ Due to higher exhaust vent pipe resistance, there is an automatic input reduction of 9% for model B2HA 150, 530 when a 4 in. dia. vent and air intake pipe are used.
- *⁴ 4 in. to 5 in. increaser field supplied.
- *⁵ 3 in. to 2 in. reducer required field supplied.
- *⁶ There is an automatic input reduction of 2%.
- *⁷ There is an automatic input reduction of 5%.

Note: For combination of different vent/air intake pipe diameters, such as Ø 3 in. stainless steel vent with Ø 2 in. (CVPC, PVC, ABS) air intake pipe, the total equivalent length must be used for the smaller pipe diameter. Minimum vent length is 3.3 ft. (1 m).

- Vitodens 100-W B1HA 26, 35, 94, 125
- Vitodens 100-W B1KA 35, 125
- Vitodens 222-F B2TB 19, 35, 68, 125
- Vitodens 200-W B2HA 19, 28, 35
- Vitodens 200-W B2HB 19, 26, 35, 68, 94, 125
- Vitodens 100-W B1HE 85, 120, 150, 199
- Vitodens 100-W B1KE 120, 199
- Vitodens 200-W B2HE 85, 120, 150, 199

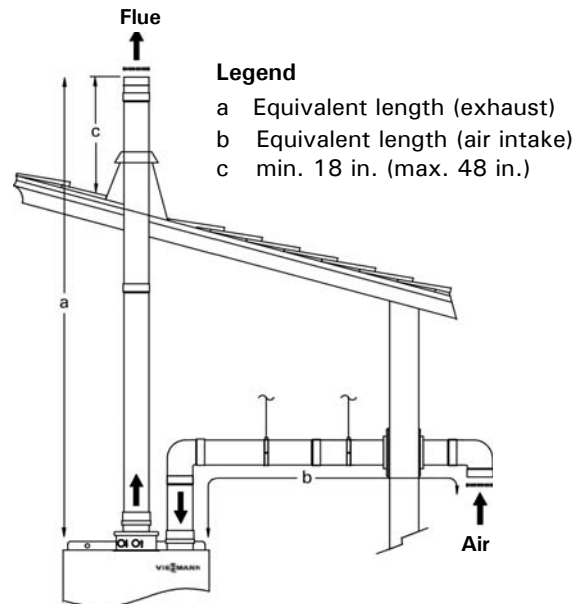

Vent Length Requirements *(continued)*

Maximum vent/air intake pipe length - horizontal/vertical (hybrid system) *(continued)*

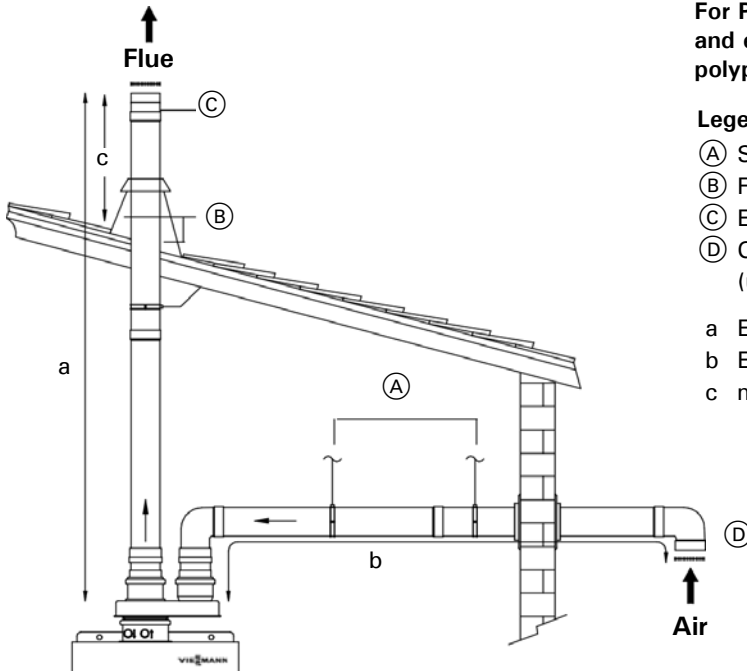

IMPORTANT

For PP(s) systems, all exhaust vent and air intake piping and elbows exposed outside, must be UV resistant polypropylene (supplied by the vent manufacturer).

Legend

- (A) Support system
 - (B) Flashings
 - (C) Exhaust (straight coupling) with screen
 - (D) Combustion air intake with screen (use of the combustion intake screen is optional).
- a Equivalent length (exhaust)
 b Equivalent length (air intake)
 c min. 18 in. (max. 48 in.)

Vitodens 200-W B2HA 45, 60, 80, 88, 100, 112, 150, 285, 311, 352, 399, 530
 Vitodens 200-W B2HB 45, 57, 160, 199

Standard Elbows

For plastic pipe only

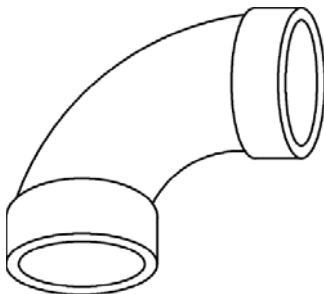

90° long sweep elbow

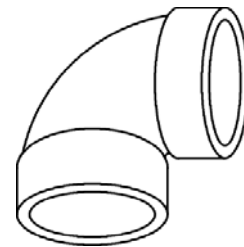

90° short sweep elbow

Standard elbows

Material	short 90° elbow equivalent length ft. (m)	long 90° elbow equivalent length ft. (m)	long 45° elbow equivalent length ft. (m)	short 87° elbow equivalent length ft. (m)	long 87° elbow / 87° inspection tee ft. (m)
Stainless steel	--	3 (0.9)	2 (0.6)	--	-
CPVC plastic pipe	8 (2.4)	5 (1.5)	3 (0.9)	--	-
PP(s)	--	--	3 (0.9)	8 (2.4)	5 (1.5)

Equivalent lengths of venting components may vary between vent manufacturers, use manufacturers values when calculating vent system equivalent lengths.

Vent Length Requirements *(continued)*

Equivalent vent length calculation example - stainless steel system with plastic air intake pipe

Vent type	Type of fitting	Equivalent length ft. (m)
Exhaust vent pipe	90° elbow (stainless steel)	3 (0.9)
	45° elbow (stainless steel)	2 (0.6)
Air intake pipe	90° elbow (ABS/PVC)	5 (1.5)
	45° elbow (ABS/PVC)	3 (0.9)

Equivalent lengths of venting components may vary between vent manufacturers, use manufacturers values when calculating vent system equivalent lengths.

IMPORTANT

Always include vent termination length in calculations.

Equivalent vent length calculation example (Vitodens WB1B and B2TA systems diameter 3 in.)

Maximum allowable equivalent length is 164 ft. (50 m) (see table below and illustration on page 54).

2 x 90° stainless steel elbow.....6 ft. (1.8 m)
 2 x 45° stainless steel elbow.....4 ft. (1.2 m)

Air intake pipe

1 x 90° plastic (ABS/CPVC/PVC) elbow.....5 ft. (1.5 m)
 1 x 45° plastic (ABS/CPVC/PVC) elbow.....3 ft. (0.9 m)
 Exhaust vent pipe.....10 ft. (3.0 m)
 Air intake pipe.....10 ft. (3.0 m)

Combined total equivalent vent length _____
 (a + b).....38 ft. (11.5 m)

Equivalent vent length calculation example - CPVC system

Type of fitting	Equivalent length ft. (m)
90° long sweep elbow (CPVC)	5 (1.5)
45° long sweep elbow (CPVC)	3 (0.9)

Equivalent lengths of venting components may vary between vent manufacturers, use manufacturers values when calculating vent system equivalent lengths.

Equivalent vent length calculation example (Vitodens WB1B systems diameter 2 in.)

Maximum allowable equivalent length is 98 ft. (30 m) (see table on page 49 and illustration below)

2 x 90° elbow.....10 ft. (3.0 m)
 4 x 45° elbow.....12 ft. (3.6 m)
 Exhaust vent pipe.....10 ft. (3.0 m)
 Air intake pipe.....10 ft. (3.0 m)

Combined total equivalent vent length _____
 (a + b).....42 ft. (12.8 m)

Vent Length Requirements *(continued)*

Equivalent vent length calculation example - CPVC system *(continued)*

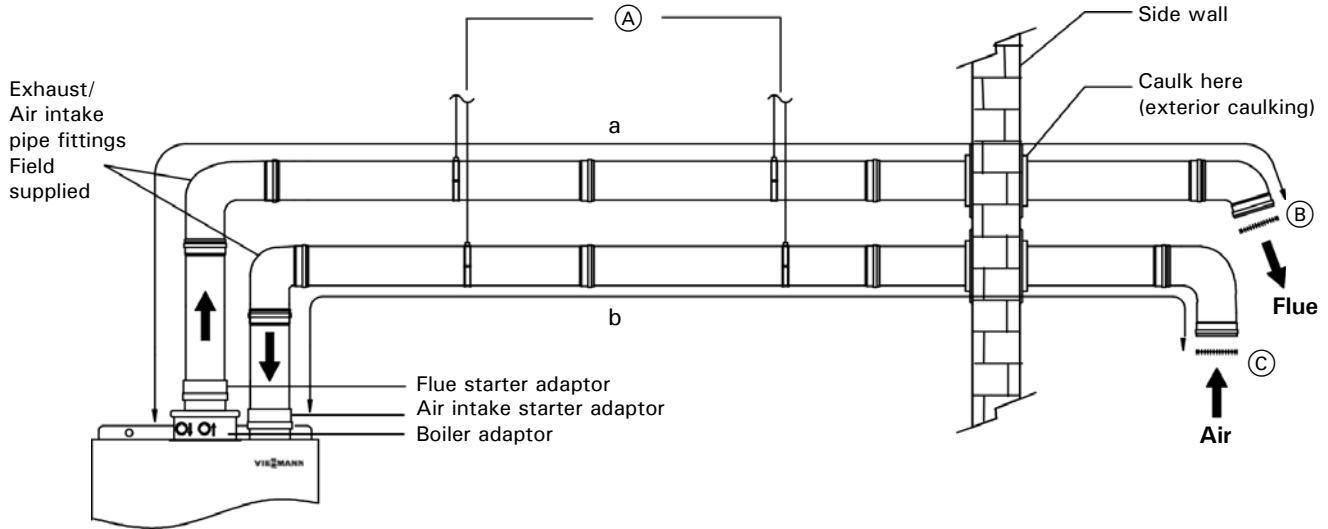

- Vitodens 100-W B1HA 26, 35, 94, 125
- Vitodens 100-W B1KA 35, 125
- Vitodens 222-F B2TB 19, 35, 68, 125
- Vitodens 200-W B2HA 19, 28, 35
- Vitodens 200-W B2HB 19, 26, 35, 68, 94, 125
- Vitodens 100-W B1HE 85, 120, 150, 199
- Vitodens 100-W B1KE 120, 199
- Vitodens 200-W B2HE 85, 120, 150, 199

Legend

- (A) Support system
- (B) Exhaust pipe termination with screen
- (C) Combustion air intake with screen
(use of the combustion intake screen is optional).
- a Equivalent vent length (exhaust)
- b Equivalent vent length (air intake)

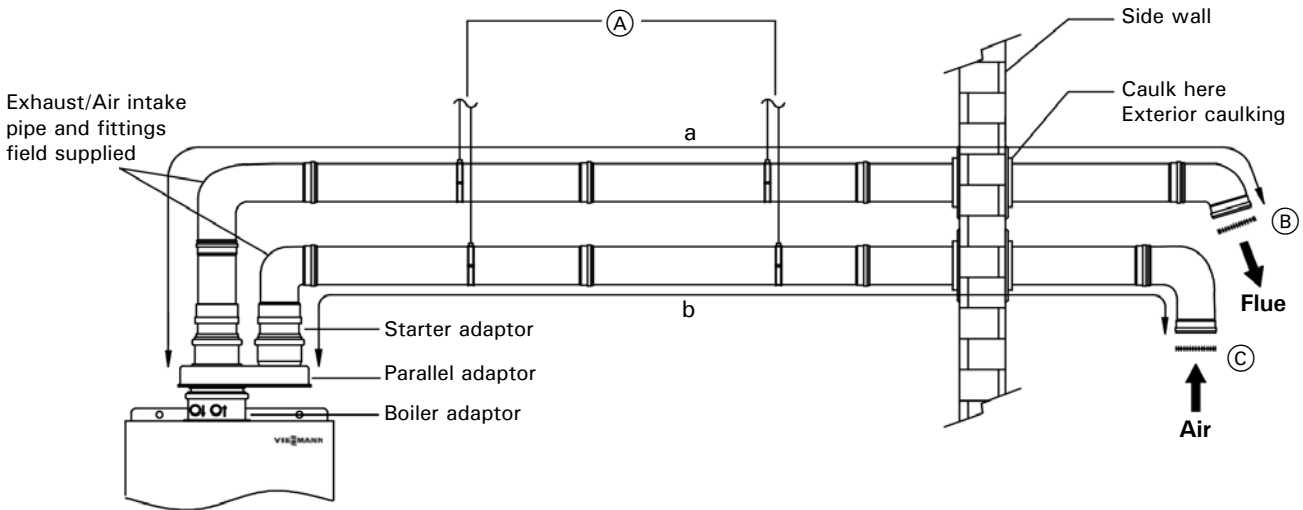

- Vitodens 200-W B2HA 45, 60, 88, 100, 112, 150, 285, 311, 352, 399, 530
- Vitodens 200-W B2HB 45, 57, 160, 199

Legend

- (A) Support system
- (B) Exhaust pipe termination with screen
- (C) Combustion air intake with screen
(use of the combustion intake screen is optional).
- a Equivalent vent length (exhaust)
- b Equivalent vent length (air intake)

Component Parts of the PP(s) Venting System

Vertical pipe system

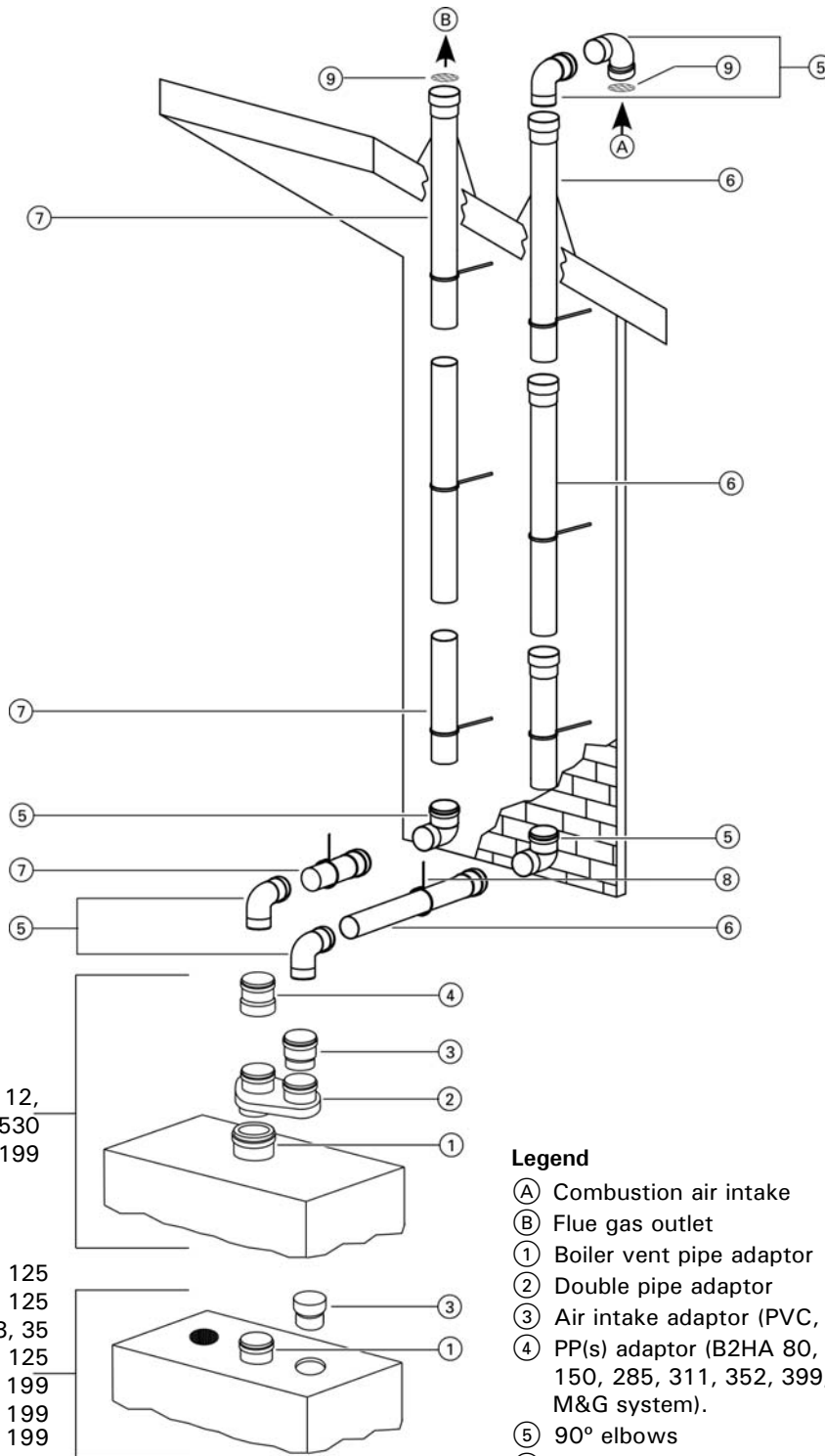

B2HA 45, 60, 80, 88, 112,
150, 285, 311, 352, 399, 530
B2HB 45, 57, 160, 199

B1HA 26, 35, 94, 125
B1KA 35, 125
B2HA 19, 28, 35
B1HE 85, 120, 150, 199
B1KE 120, 199
B2HE 85, 120, 150, 199

Legend

- (A) Combustion air intake
- (B) Flue gas outlet
- ① Boiler vent pipe adaptor
- ② Double pipe adaptor
- ③ Air intake adaptor (PVC, CPVC, ABS)
- ④ PP(s) adaptor (B2HA 80, 88, 100, 112, 150, 285, 311, 352, 399, 530 only with M&G system).
- ⑤ 90° elbows
- ⑥ Combustion air intake straight pipe
- ⑦ Straight vent pipe
- ⑧ Pipe support system
- ⑨ Bird screen (use of the combustion intake screen is optional).
- ⑩ Wall strap with locking band at each joint, as supplied by manufacturer.

IMPORTANT

For PP(s) systems, all exhaust vent and air intake piping and elbows exposed outside, must be UV resistant polypropylene (supplied by the vent manufacturer). Always include vent termination length in calculations.

6167 815 - 04

Component Parts of the PP(s) Venting System *(continued)*

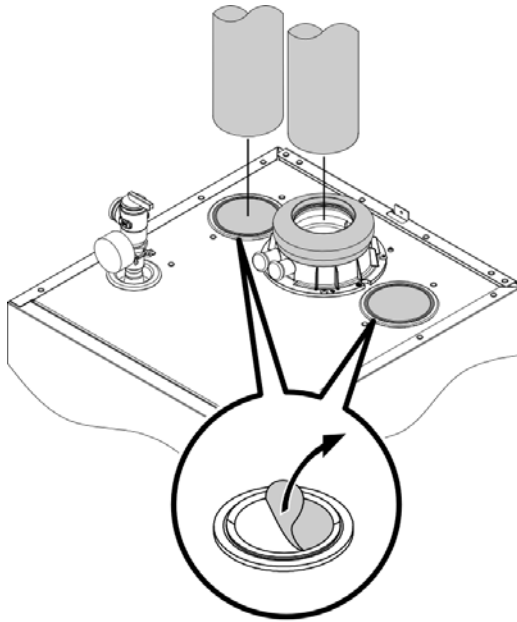

2 inch Direct Vent 2 Pipe Venting Systems (B1HE/B1KE 85/120, B2HE 85/120)

The Coaxial vent seal must be installed (supplied with the boiler).

The right side gasket is sized for a 3½ inch (89 mm) outside diameter combustion air piping (PVC, CPVC or ABS), the left side is sized for a 3 inch (80 mm) outside diameter combustion air piping (PPs). If required, the gasket position can be interchanged for direct vent two pipe venting systems. Only remove the center portion for the gasket being used, Do not damage the sealing lip on the outside ring of the combustion air gasket.

Carefully detach the inner part of the combustion air gasket, preferably without using a tool.

System Components

PPs Venting Material (with PVC, CPVC, or ABS
Combustion Air piping Material)

CPVC Venting Material (with PVC, CPVC, or ABS
Combustion Air piping Material)

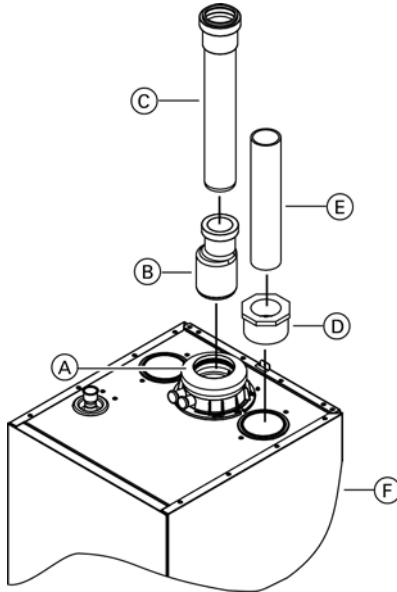

Legend

- (A) Coaxial Vent Seal (supplied with boiler)
- (B) PPs Reducer 80 mm to 60 mm
- (C) PPs Venting Material 60 mm (2¾ in.)
- (D) Reducing Bushing 3 in. to 2 in.
- (E) Combustion air intake material 2 in.
- (F) Vitodens 100 B1HE/KE 85/120
Vitodens 200 B2HE 85/120

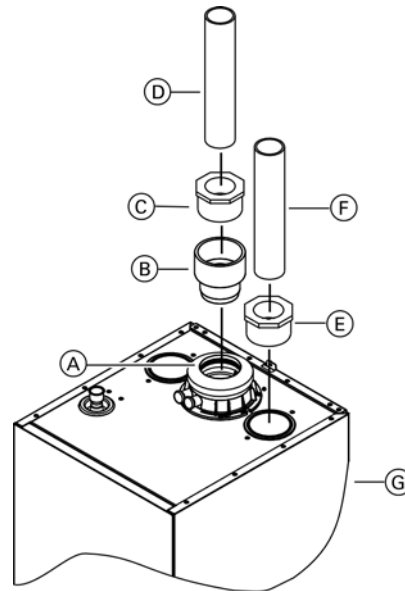

Legend

- (A) Coaxial Vent Seal (supplied with boiler)
- (B) CPVC Vent Adaptor 80 mm to 3 in. (Viessmann PN 7134 770)
- (C) CPVC Reducing Bushing 3 in. to 2 in.
- (D) CPVC Venting Material 2 in.
- (E) Reducing Bushing 3 in. to 2 in.
- (F) Combustion air intake material 2 in.
- (G) Vitodens 100 B1HE/KE 85/120
Vitodens 200 B2HE 85/120

Component Parts of the PP(s) Venting System *(continued)*

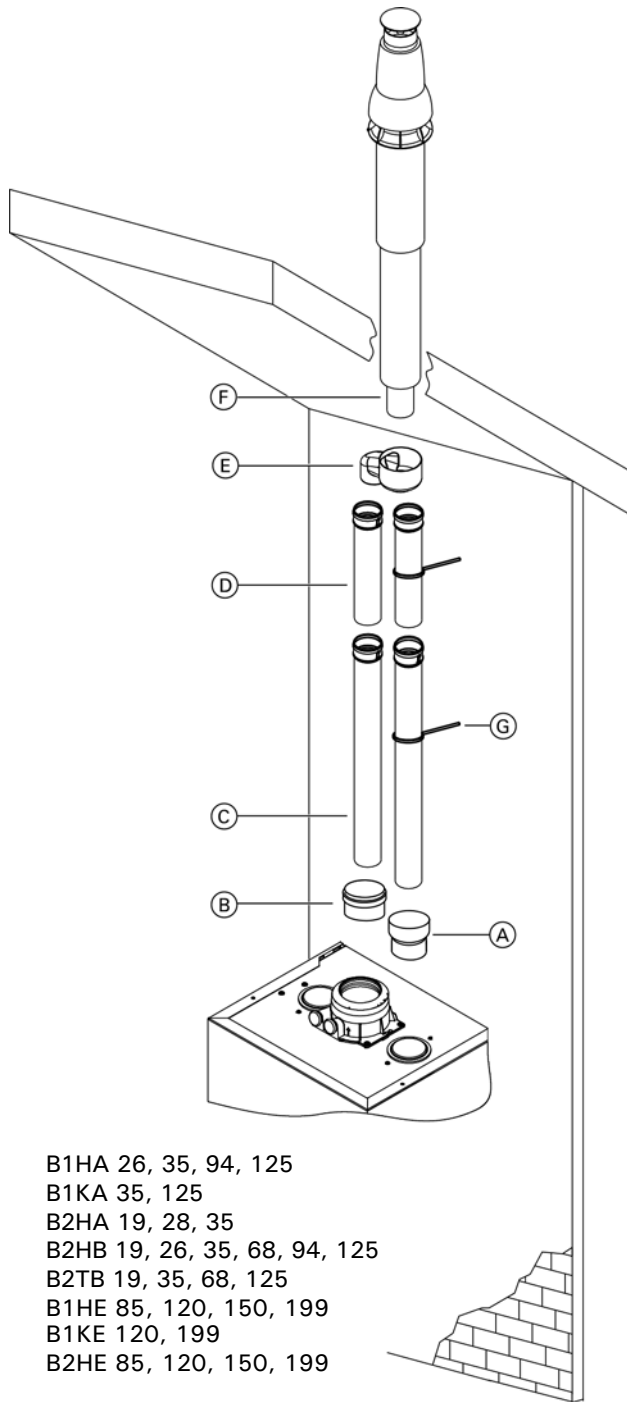

- B1HA 26, 35, 94, 125
- B1KA 35, 125
- B2HA 19, 28, 35
- B2HB 19, 26, 35, 68, 94, 125
- B2TB 19, 35, 68, 125
- B1HE 85, 120, 150, 199
- B1KE 120, 199
- B2HE 85, 120, 150, 199

Legend

- (A) Air intake adaptor
- (B) Vent adaptor (if required) field supplied
- (C) Long vent length 3.3 ft. (1 m)
- (D) Short vent length 1.6 ft. (0.5 m)
- (E) 2 pipe to coaxial adaptor (field supplied). Consult Manufacturers Venting Instructions.
- (F) Vertical coaxial termination
- (G) Pipe support system

IMPORTANT

For PP(s) systems, all exhaust vent and air intake piping and elbows exposed outside, must be UV resistant polypropylene (supplied by the vent manufacturer). Always include vent termination length in calculations.

Component Parts of the PP(s) Venting System *(continued)*

Horizontal pipe system

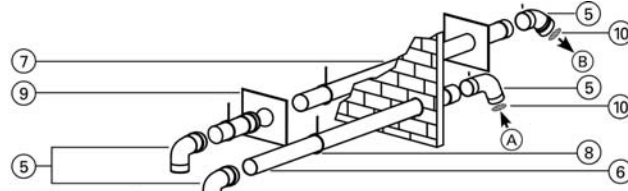

B2HA 45, 60, 88, 100, 112, 150, 285, 311, 352, 399, 530
B2HB 45, 57, 160, 199

B1HA 26, 35, 94, 125
B1KA 35, 125
B2HA 19, 28, 35
B2HB 19, 26, 35, 68, 94, 125
B2TB 19, 35, 68, 125
B1HE 85, 120, 150, 199
B1KE 120, 199
B2HE 85, 120, 150, 199

Legend

- (A) Combustion air intake
 - (B) Flue gas outlet
 - (1) Boiler vent pipe adaptor
 - (2) Double pipe adaptor
 - (3) Air intake adaptor (PVC, CPVC, ABS)
 - (4) PP(s) adaptor B2HA 80, 88, 100, 112, 150, 285, 311, 352, 399, 530 only with M&G system)
 - (5) 90° elbows
 - (6) Combustion air intake straight pipe
 - (7) Straight vent pipe
 - (8) Pipe support
 - (9) Wall plate
 - (10) Bird screen
- (use of the combustion intake screen is optional).

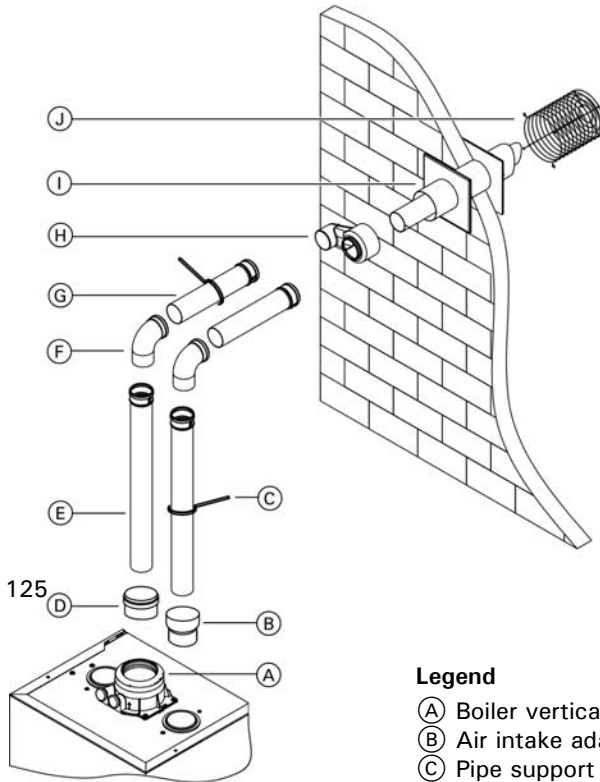

B1HA 26, 35, 94, 125
B1KA 35, 125
B2HA 19, 28, 35
B2HB 19, 26, 35, 68, 94, 125
B2TB 19, 35, 68, 125
B1HE 85, 120, 150, 199
B1KE 120, 199
B2HE 85, 120, 150, 199

Legend

- (A) Boiler vertical coaxial termination
- (B) Air intake adaptor (if required) field supplied
- (C) Pipe support system
- (D) Vent adaptor (if required) field supplied.
- (E) Long vent length 3.3 ft. (1 m)
- (F) 90° elbows
- (G) Short vent length 1.6 ft. (0.5 m)
- (H) 2 pipe to coaxial adaptor (field supplied). Consult Manufacturers Venting Instructions.
- (I) Horizontal coaxial termination
- (J) Bird screen

IMPORTANT

For PP(s) systems, all exhaust vent and air intake piping and elbows exposed outside, must be UV resistant polypropylene (supplied by the vent manufacturer).

Always include vent termination length in calculations.

Vent Requirements

Combustion air supply

This boiler requires fresh air for safe operation and must be installed in a mechanical room where there are provisions for adequate combustion and ventilation air.

There are no provisions available on the Vitodens boiler to interlock it with an external combustion air blower.

The Vitodens boiler is suitable for sidewall, as well as vertical venting using field supplied venting material. The Vitodens 100-W, 222-F and 200-W boilers are approved for direct exhaust (non-sealed combustion) operation in both, horizontal and vertical arrangements.

Provisions for combustion and ventilation air must be made in accordance with CAN/CSA-B149.1 or .2 Natural Gas Installation Codes (for installations in Canada) or in accordance with sections for Combustion and Ventilation Air, of the National Fuel Gas Code, ANSI Z223.1 or applicable provisions of local codes (for installations in the U.S.A.) Always use latest edition of applicable standard.

Follow local codes to properly isolate the vent pipe when passing through floors, ceilings and roof.

Whenever possible, install boiler near an outside wall so that it is easy to duct fresh air directly to the boiler area. Refer to national codes for duct sizing. Round ducts may be used.

WARNING

Failure to provide an adequate supply of fresh combustion air can cause poisonous flue gases to enter living space, which can cause severe personal injury or loss of life.

The boiler must be vented and supplied with combustion air and exhaust vents as described in this section. Ensure the vent and combustion air supply comply with these instructions.

The boiler location should never be under negative pressure. Exhaust fans, attic fans, or dryer fans may cause air to be exhausted at a rate higher than the air can enter the structure for safe combustion. Corrective action must be taken to ensure enough air is available. Never cover the boiler or store debris or other materials near the boiler, or in any way block the flow of adequate fresh combustion air to the boiler.

You must know the free area of louvers used to cover up the combustion and ventilation openings in closet installations. If you do not know the free area, assume 20% for wood louvers and 60-75% free area for metal louvers. When using louvers, the openings have to be made larger. For example, a free 14 in. x 6 in. opening becomes a 14 in. x 10 in. opening for a grill containing metal louvers.

CAUTION

Do not store chemicals containing chlorine or other corrosive materials near the boiler, such as bleach, cleaning solvents, detergents, acids, hair spray, spray cans, paint thinners, paint, water softener salt, perchloroethylene, or carbon tetra chloride.

Vent Requirements *(continued)***Combustion air supply** *(continued)*

Inspect all finished exhaust vent/air intake piping to ensure:

- Vent pipe and fittings are of approved material.
- Acceptable size, length and number of elbows on combined vent pipe system.
- Installation is in accordance with prevailing provisions of local codes.
- Installation complies with the requirements of these instructions, as well as the exhaust vent supplier's instructions.

The exhaust vent system and terminations may be installed in one of the following types of terminations:

1. Horizontal exhaust vent
2. Vertical exhaust vent

CAUTION

Exposure to corrosive materials can cause heat exchanger corrosion and failure.

CAUTION

Do not locate boiler in areas where high dust levels or high humidity levels are present.

CAUTION *

Do not install boiler during construction involving drywall or heavy dust of any kind. Dust can accumulate in the burners and cause sooting. Install boiler after all heavy dust construction is completed.

* Typically when the boiler is used as a temporary heat source during the building construction phase.

CAUTION

If the boiler has been exposed to high dust levels, all burners and the heat exchanger must be cleaned prior to use.

Note: If above criteria are not properly observed and boiler damage results, any warranty on the complete boiler and related components will be null and void.

General Installation Information

The Vitodens boiler must be located in such a way that the vent length is as short as possible and that the vent can be routed as directly (and with as few bends) as possible.

The minimum equivalent vent length is 4 ft. (1.2 m). See table on page 72 and 73 for maximum vent lengths.

All products of combustion must be safely vented to the outdoors.

All Vitodens boilers vent under positive pressure and are Category IV boilers.

WARNING

Failure to provide an adequate supply of fresh combustion air can cause poisonous flue gases to enter living space, which can cause severe personal injury or loss of life.

Viessmann recommends that the entire vent system be checked by a licensed professional heating contractor at least once each year following initial installation.

The remaining space surrounding a chimney liner, gas vent, or special gas vent or plastic piping installed within a masonry, metal or factory-built flue shall not be used to supply combustion air.

The stainless steel special venting system is completely sealed when fully assembled. Locking bands are used to reinforce the joints between pipe and fittings.

WARNING

Different manufacturers offer a number of different joint systems and adhesives. Do not mix pipes, fittings and/or joining methods from different manufacturers. Failure to comply could result in leakage, potentially causing personal injury or death.

Do not install vent pipe such that flue gases flow downwards. The direction of flue gas flow must be vertically upwards or horizontal with an upward slope.

Ensure there is no flue gas leakage into the area in which the boiler is installed.

Check joints for leaks with the gas supply turned off and the fan running. Use a soapy solution to check for vent leaks.

Condensate must drain from the flue pipe to the boiler. Ensure a suitable gradient of at least 2-3° based on the vent manufacturer's system design [example: for a 3° system approx. 2 in. per 3.3 ft. (50 mm per 1 m) on any horizontal venting components].

No condensate trap is required in the vent pipe system.

General Installation Information

Installation steps (outline)

Exhaust vent pipe material

Use only the materials listed on page 61 for exhaust vent pipe fittings.

- Cut the pipe end square and remove all burrs and debris from joints and fittings.
- If using CPVC special vent material for exhaust vent pipe, all joints must be properly cleaned, primed and cemented. Use only cement and primer approved for the use with the pipe material. See table on page 61 for approved solvent cement material.

CAUTION

For solvent cement and primer:

- Use only in well ventilated areas
- Do not use near flame or open fire
- Use only the solvent cement and primer appropriate for the venting material being used
- Solvent cements for plastic pipe are flammable liquids and must be kept away from all sources of ignition

- No low point is allowed in the exhaust vent pipe system, unless a proper drain pipe is used to allow condensate to drain.
- All PP(s) vent material and air intake (if PP(s) used) must be ULC S636 or UL1738 listed, manufactured by M&G / DuraVent, Centrotherm InnoFlue, PolyFlue, or ECCO manufacturing.

WARNING

Ensure that the entire venting system is protected from physical damage. A damaged venting system may cause unsafe conditions.

WARNING

The venting system is approved for indoor installations only.
Do not install the venting system outdoors.

- Route vent pipe as directly as possible and with as few bends as possible to the boiler.
- Condensate must drain from the flue pipe to the boiler. Ensure a suitable gradient of at least 2-3° based on the vent manufacturer's system design [example: for a 3° system approx. 2 in. per 3.3 ft. (50 mm per 1 m) on any horizontal venting components].
- Use a hacksaw or sheet metal snips (for stainless steel to cut pipes to length (if necessary)). Use a file to smooth rough edges. Pipe must be round and not bent into an oval shape.
- Check proper location of gaskets in rigid PP(s) pipe collars. (Only use supplied parts with the polypropylene venting system). Apply water (or lubricant supplied with the venting system) to lubricate the joint ends of the vent pipe collar and if used, the air intake pipe collar.
- Slide pipes into each other with a gentle twisting motion.

IMPORTANT

When cutting pipes to length, debur and clean pipes.

In conjunction with these instructions, follow the installation instructions supplied by the special venting manufacturer.

- All piping must be fully supported. Use pipe hangers at a minimum of 48 in. (1219 mm) intervals to prevent sagging of the pipe.
- The exhaust vent pipe and fittings must be securely supported by a support system suitable for the weight and design of the material employed. Contact your local vent material supplier for more information specific to your installations.

IMPORTANT

Ensure that the exhaust vent pipes are properly supported. The Vitodens boiler is not designed to support the weight of the exhaust vent pipe system.

- Field supplied increaser fittings (transitions) should always be made in vertical sections of pipe to prevent accumulation of condensate in the vent pipe.
- If exhaust vent pipe system passes through an unheated space, such as an attic, it must be insulated. The insulation must have an R value sufficient to prevent freezing of the condensate. Armaflex insulation with 1/2 in. thickness and higher can be used.

General Installation Information *(continued)*

 **CAUTION**
Do not use cellular (foam) core pipe material to vent the Vitodens boiler.

Support system

The venting system must be securely supported by a support system suitable for the weight and design of the materials employed.

The Vitodens boiler is not designed to support the weight of the venting system.

Use supports to transfer the weight of an installation to the building structure. There are different types of supports available and their capacity varies with each type and diameter.

The following support types are available at your local vent material supplier...

- anchor plate
- wall support
- roof support
- floor support
- suspension band (hanger).

In addition to the support types listed, mounting clips can be used to support the weight of the venting system.

Contact your vent material supplier for more information specific to your installation.

Follow the installation instructions supplied by the special venting manufacturer.

 **CAUTION**
Do not use PVC material in exhaust system.

Additional requirements for stainless steel vent pipe material

Use a special stainless steel venting system (UL/ULC listed for category IV) for horizontal or vertical venting of the Vitodens boilers.

See tables on page 63 and contact one of the suppliers (see listing on right) to order.

Prior to installation, check that the correct single-pipe vent parts were ordered and supplied.

See tables on page 63 for special stainless steel single-pipe vent starter adaptor, coaxial increasers and bird screen models required for your installation. In case of discrepancies, contact original parts supplier.

Exhaust vent pipe connection to boiler

The vent connection to the Vitodens boiler must be made with a coaxial increaser (B1HA 26, 35, 94, 125, B1KA 35, 125, B2TB 19, 35, 68, 125, B2HA 19, 28, 35 models) and starter stainless steel adaptors (supplied by others, see tables on page 68). The starter adaptors are intended for a slip fit and slide into the boiler adaptor with a gentle twisting motion.

Note: For stainless steel exhaust vent system, the minimum pipe diameter is 3 in. (76 mm).

Note: The Vitodens boiler has passed the zero inches vent clearance to combustibles testing requirements dictated by the Harmonized Standard ANSI Z21.13. CSA 4.9. and therefore is listed for zero clearance to combustibles when vented with a single pipe special venting system. The zero inches vent clearance to combustibles for the Vitodens boiler supersedes the clearance to combustibles listing that appears on the special venting system label.

Flexmaster Canada Ltd. www.novaflex.com	ICC - Industrial Chimney Co. www.icc-rsf.com
ProTech Systems, Inc. www.protechinfo.com	Heat-Fab, Inc. www.selkirkcorp.com
Security Chimneys International Ltd. www.securitychimneys.com	Z-FLEX US Inc. NovaFlex Group www.novaflex.com

IMPORTANT

For exhaust vent pipe material:
Do not use any other vent material.
Do not use galvanized pipe, plastic pipe and/or chimney liners of any kind.

 **WARNING**
The use of vent material other than stainless steel, positive pressure vent pipe and fittings can cause property damage, severe personal injury and/or loss of life.

General Installation Information *(continued)***Additional requirements for stainless steel vent pipe material** *(continued)***Exhaust vent termination options**

Supplier	Boiler Model	Stainless Steel Slip Joint Starter Adaptor		Vertical Termination Coupling with Screen
Flexmaster / Z-Flex	B1HA 26, 35, 94, 125, B1KA 35, 125	3 in.	2SVSVB23S	3 in. 2SVSTP(F,X)03
	B2HA 19, 28, 35	3 in.	2SVSVB23S	3 in. 2SVSTP(F,X)03
	B2TB 19, 35, B2HB 19, 26, 35, 68, 94, 125	3 in.	2SVSVB23S	3 in. 2SVSTP(F,X)03
	B2HA 45, 60, B2HB 45, 57, 160, 199	3 in.	2SVSVB23S	3 in. 2SVSTP(F,X)03
	B2HA 80, 88, 100, 112, 150, 285, 311, 352, 399, 530, B1HE 85, 120, 150, 199, B1KE 120, 199, B2HE 85, 120, 150, 199	4 in.	2SVSVB24S	4 in. 2SVSTP(F,X)04
		3 in.	2SVSVB23S	3 in. 2SVSTP(F,X)03
Heat-Fab	B1HA 26, 35, 94, 125, B1KA 35, 125	3 in.	9301VSMN	3 in. 9392
	B2HA 19, 28, 35, 68, 94, 125	3 in.	9301VSMN	3 in. 9392
	B2TB 19, 35, B2HB 19, 26, 35	3 in.	9301VSMN	3 in. 9392
	B2HA 45, 60, B2HB 45, 57, 160, 199	3 in.	9301VSMN	3 in. 9392
	B2HA 80, 88, 100, 112, 150, 285, 311, 352, 399, 530, B1HE 85, 120, 150, 199, B1KE 120, 199, B2HE 85, 120, 150, 199	4 in.	9401VSMN	4 in. 9492
		3 in.	9301VSMN	3 in. 9392
ProTech	B1HA 26, 35, 94, 125, B1KA 35, 125	3 in.	300568	3 in. 300186
	B2HA 19, 28, 35, 68, 94, 125	3 in.	300568	3 in. 300186
	B2TB 19, 35, B2HB 19, 26, 35	3 in.	300568	3 in. 300186
	B2HA 45, 60, B2HB 45, 57, 160, 199	3 in.	300568	3 in. 300186
	B2HA 80, 88, 100, 112, 150, 285, 311, 352, 399, 530, B1HE 85, 120, 150, 199, B1KE 120, 199, B2HE 85, 120, 150, 199	4 in.	300569	4 in. 300187
		3 in.	300568	3 in. 300186
Security Chimneys	B1HA 26, 35, 94, 125, B1KA 35, 125	3 in.	CTX-V3	Contact supplier
	B2HA 19, 28, 35, 68, 94, 125	3 in.	CTX-V3	
	B2TB 19, 35, B2HB 19, 26, 35	3 in.	CTX-V3	
	B2HA 45, 60, B2HB 45, 57, 160, 199	3 in.	CTX-V3	
	B2HA 80, 88, 100, 112, 150, 285, 311, 352, 399, 530, B1HE 85, 120, 150, 199, B1KE 120, 199, B2HE 85, 120, 150, 199	4 in.	CTX-V4	
		3 in.	CTX-V3	

Note: Minimum vent pipe diameter with stainless steel vent system is 3 in. (76 mm).

General Installation Information *(continued)***Other exhaust vent termination options (horizontal installation)**

Supplier	Boiler Model	Termination Elbow with Screen 90° or 45°	Termination Tee with Screen	Termination Hood with Screen
Flexmaster	B1HA 26, 35, 94, 125, B1KA 35, 125 B2TB 19, 35, 68, 125 B2HA 19, 28, 35, B2HB 19, 26, 35, 68, 94, 125 B2HA 45, 60 B2HB 45, 57, 160, 199, B2HA 80, 88, 100, 112, 150, 285, 311, 352, 399, 530, B1HE 85, 120, 150, 199, B1KE 120, 199, B2HE 85, 120, 150, 199	Contact supplier	Contact supplier	Contact supplier
Heat-Fab	B1HA 26, 35, 94, 125, B1KA 35, 125 B2TB 19, 35, 68, 125 B2HA 19, 28, 35, B2HB 19, 26, 35, 68, 94, 125 B2HA 45, 60 B2HB 45, 57, 160, 199, B2HA 80, 88, 100, 112, 150, 285, 311, 352, 399, 530, B1HE 85, 120, 150, 199, B1KE 120, 199, B2HE 85, 120, 150, 199	Contact supplier	Contact supplier	Contact supplier
ProTech	B1HA 26, 35, 94, 125, B1KA 35, B2TB 19, 35, B2HA 19, 28, 35, B2HB 19, 26, 35 B2HA 45, 60, B2HB 45, 57, 160, 199, B2HA 80, 88, 100, 112, 150, 285, 311, 352, 399, 530, B1HE 85, 120, 150, 199, B1KE 120, 199, B2HE 85, 120, 150, 199	Contact supplier	Contact supplier	Contact supplier

General Installation Information *(continued)*

Additional requirements for stainless steel vent pipe material *(continued)*

Coaxial increaser [min. stainless steel pipe diameter is 3 in. (76 mm)]
 The PP(s) increaser is required for the following boiler models.

Supplier	Boiler Model	PP(s) increaser	Quantity
Viessmann	B1HA 26, 35, 94, 125, B1KA 35, 125 B2HA 19, 28, 35, B2TB 19, 35, 68, 125, B2HB 19, 26, 35, 68, 94, 125	(60 to 80 mm)	1

When utilizing the combustion air inlet seal for Vitodens 100 WB1B, B1HA, B1KA, Vitodens 200 B2HA/B and Vitodens 222 B2TB series boilers, remove the inlet seal, tear out center section and install the remaining rubber seal back into the air inlet opening.

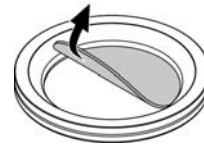
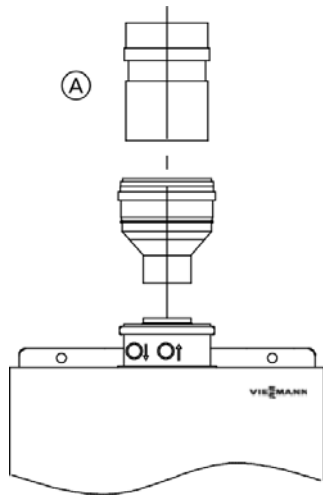

for Vitodens 100 series, 200 B2HA/B and 222 B2TB boilers
 If using annular air gap, remove and discard air inlet cover or use optional opening to the left or right.

Boiler models Vitodens 100 B1HA 26, 35,94, 125,
 B1KA 35, 125,
 Vitodens 200 B2HA 19, 28, 35,
 B2HB 19, 26, 35,68, 94, 125
 B2TB 19, 35, 68, 125

Legend

(A) Stainless steel slip joint vent starter adaptor

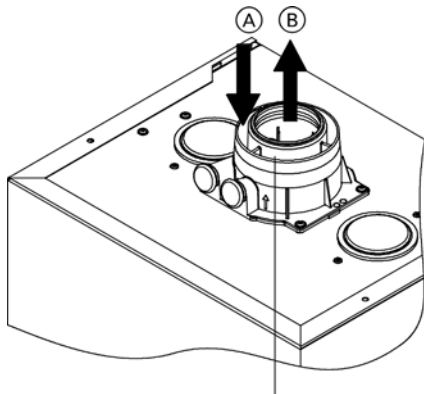

Coaxial combustion air inlet cover shown removed.

Legend

(A) Combustion air (requires 2 in. CPVC adaptor)
 (B) Flue gas (requires 2 inc. CPVC adaptor)

General Installation Information *(continued)*

Additional requirements for stainless steel vent pipe material *(continued)*

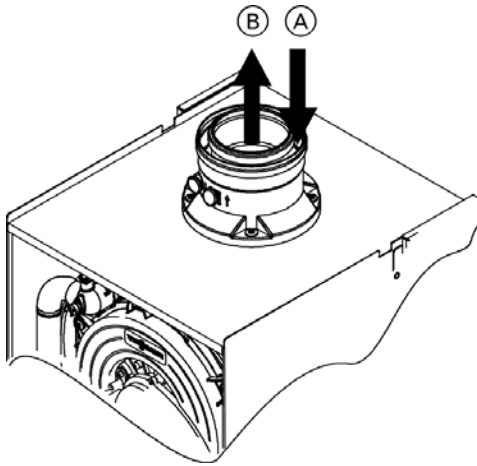

Coaxial boiler vent pipe connection

Legend

- (A) Combustion air intake
- (B) Flue gas

Starter adaptor for;

- B2HA 45, 60, 80, 88, 100, 112, 150, 285, 311, 352, 399, 530**
- B2HB 45, 57, 160, 199**

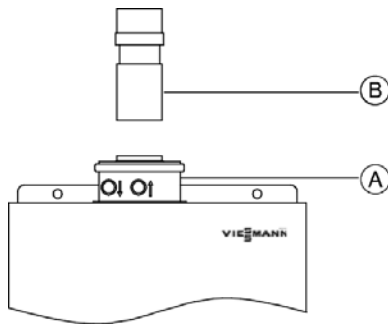

Legend

- (A) Boiler adaptor
- (B) Stainless steel starter adaptor [max. insertion 2 1/2 in. (64 mm)]

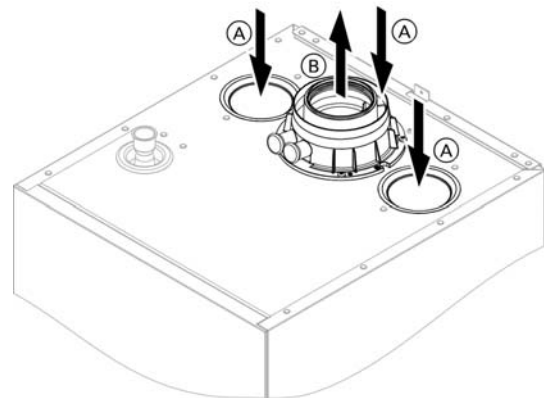

Legend

- (A) Combustion air
- (B) Flue gas

Starter adaptor for;

- B1HE 85, 120, 150, 199**
- B1KE 120, 199**
- B2HE 85, 120, 150, 199**

Use the annular air gap or install the air inlet cover and use the optional left or right opening.

When utilizing the combustion air inlet seal for Vitodens 100 B1HE, B1KE and Vitodens 200 B2HE series boilers, remove the inlet seal, tear out center section and install the remaining rubber seal back into the air inlet opening.

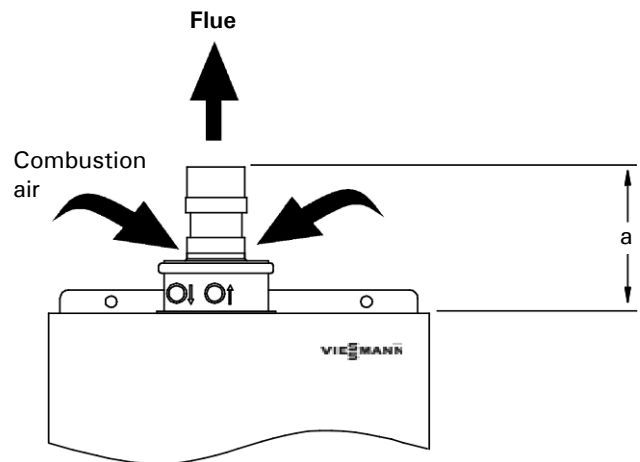
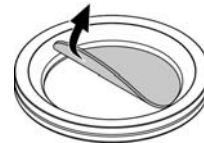

a 6.5 in
(165 mm)

General Installation Information *(continued)***Additional requirements for CPVC vent pipe material**

Use UL/ULC listed special plastic pipe (CPVC) for horizontal (side wall) or vertical (roof) venting of the Vitodens boilers. Use CPVC classified as type BH class IIB 90°C vent.

See table on page 68 and contact Viessmann to order.

Prior to installation, check that the correct single-pipe vent parts have been ordered and supplied.

See table on page 68 for special starter adaptor and bird screen models required for your installation.

Exhaust vent connection to boiler

The vent connection to the Vitodens boiler must be made with CPVC starter adaptors (see table on page 68). The starter adaptors are intended for a slip fit and slide into the boiler adaptor with a gentle twisting motion.

For a vent pipe system, one wire mesh screen (bird screen) must be ordered from Viessmann. These parts are available in pre-cut diameters of 2 in., 3 in. and 4 in. (see table on page 68).

**WARNING**

The use of vent material other than listed CPVC, positive pressure vent pipe and fittings can cause property damage, severe personal injury and/or loss of life.

Note: The Vitodens boiler has passed the zero inches vent clearance to combustibles testing requirements dictated by the Harmonized Standard ANSI Z21.13. CSA 4.9. and therefore is listed for zero clearance to combustibles when vented with a single pipe special venting system. The zero inches vent clearance to combustibles for the Vitodens boiler supersedes the clearance to combustibles listing that appears on the special venting system label.

IMPORTANT

For exhaust vent pipe material:

Do not use any other vent material.

Do not use galvanized pipe, plastic pipe and/or chimney liners of any kind.

General Installation Information *(continued)*

Required starter adaptors and mesh screen for CPVC system

Part	Boiler Model	Size	Supplier	Quantity
CPVC Starter Adaptor	B1HA 26, 35, 94, 125, B1KA 35, 125	2 in.	Viessmann	1
	B2HA 19, 28, 35	2 in.		
	B2TB 19, 35, 68, 125, B2HB 19, 26, 35, 68, 94, 125	2 in.		
	B2HA 45, 60, B2HB 45, 57, 160, 199	3 in.		
	B2HA 80, 88, 100, 112, 150, 285, 311, 352, 399, 530	4 in.		
Wire Mesh Screen for Termination Elbows/Coupling	B1HE 85, 120, 150, 199, B1KE 120, 199, B2HE 85, 120, 150, 199	3 in.	Viessmann	1
	B1HA 26, 35, 94, 125, B1KA 35, 125	2 in.		
	B2HA 19, 28, 35	2 in.		
	B2TB 19, 35, 68, 125, B2HB 19, 26, 35, 68, 94, 125	2 in.		
	B2HA 45, 60, B2HB 45, 57, 160, 199	3 in.		
B2HA 80, 88, 100, 112, 150, 285, 311, 352, 399, 530	4 in.			
B1HE 85, 120, 150, 199, B1KE 120, 199, B2HE 85, 120, 150, 199	3 in.			

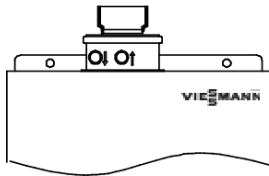
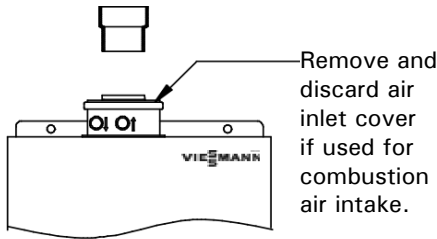
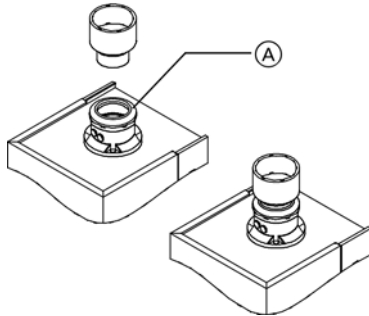

Legend

Ⓐ Combustion air inlet

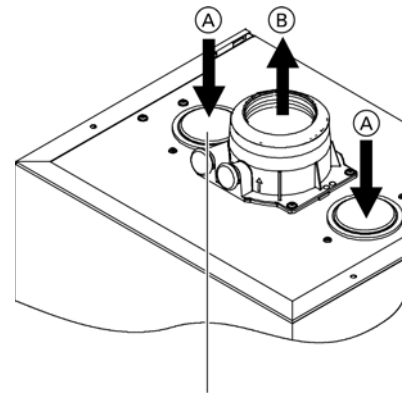

Legend

Ⓐ Combustion air
Ⓑ Flue gas

When utilizing the combustion air inlet seal for Vitodens 100 WB1B, B1HA, B1KA, B1HE, B1KE Vitodens 200 B2HA/B and Vitodens 222 B2TB series boilers, remove the inlet seal, tear out center section and install the remaining rubber seal back into the air inlet opening.

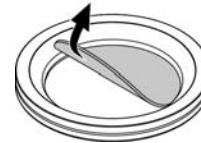

for Vitodens 100 series, 200 B2HA/B, 100 B1HE/KE, 200 B2HE and 222 B2TB boilers

If using annular air gap, remove and discard air inlet cover or use optional opening to the left or right.

Requirements for Rigid PP(s) Vent Pipe Material

IMPORTANT

When replacing parts, use original manufacturer replacement parts.

The venting system must be installed by a licensed professional heating contractor familiar with the operation and maintenance of heating boilers and venting. Before installing this product, ensure that the complete installation literature has been read. Failure to follow proper installation procedures as stated in these instructions, including vent pitch and proper boiler connections, may violate local, provincial/state, or national codes and cause unsafe conditions which may lead to severe property damage or personal injury.

Prior to installation, check that the correct single-pipe vent parts were ordered and supplied.

The venting system must be installed in accordance with local building code requirements as well as national codes. For installations in Canada use CAN/CSA-B149.1 Natural Gas Installation Code or CAN/CSA-B149.2 Propane Installation Code as applicable; in the U.S. use the National Fuel Gas Code ANSI Z223.1 or NFPA Standard 54. Always use latest edition of applicable standard.

To ensure safe operation of the boiler, Viessmann recommends that the system be inspected once a year by a qualified service technician.

Every venting system must be planned and installed for optimum performance and safety. These Installation Instructions are designed to help you determine venting requirements and limitations with respect to installation. Please read and follow these instructions carefully.

It is the responsibility of the installer to contact local building and fire officials concerning any installation restrictions and/or inspection requirements that may apply. Permits may be required before commencement of the installation.

The air intake termination for side wall air intake installations should be located on a wall that is least affected by prevailing winds. High winds may affect boiler operation.

Vent System Manufacturers

The following Coaxial and PP(s) vent system manufacturers may be contacted for assistance in designing the appropriate venting system for Vitodens 100 and Vitodens 200 boilers.

All manufacturers deliver PP(s) concentric vents in 3 sizes.

M&G / Duravent, PolyFlue	Centrotherm InnoFlue, Z-Flex, ECCO
2 - 4 in. (60 - 100 mm)	2 in. (60 mm)
3 - 5 in. (80 - 125 mm)	3 in. (80 mm)
4 - 6 in. (100 - 150 mm)	4.3 - 6.3 in. (110 - 160 mm)

For Vitodens WB2B 80, 105 and B2HA 80, 88, 100, 112, 150, 285, 311, 352, 399, 530 (with boiler flue adaptor 110 - 150) the vent manufacturers developed special transition adaptors.

Because of its sealed combustion chamber, the Vitodens gas-fired condensing boiler is suitable for operation with balanced flue.

Listed manufacturers deliver PP(s) rigid and flexible vents in the required sizes.

M&G / Duravent www.duravent.com	Centrotherm InnoFlue www.centrotherm.us.com
PolyFlue - Selkirk * www.polyflue.com	ECCO Manufacturing www.eccomfg.com
Z-FLEX US Inc. NovaFlex Group www.novaflex.com	

* Provides double pipe system with coaxial termination.

The Vitodens boiler, flue gas adaptor and parallel adaptor (if used) are approved together under CSA 4.9. ANSI Z21.13 Standard.

IMPORTANT

DO NOT mix pipe, fittings, or joining methods from different vent system manufacturers. DO NOT use adhesives of any kind with this venting system.

The vent length requirements stated on page 72 in this manual must be observed.

Flue gases are discharged via rigid PP(s) vent components to the outdoors. This vent system is constructed from flame-retardant plastic [polypropylene rated for a maximum temperature of 230°F (110°C)].

Boiler Connections with PP(s) System

Vent pipe starter adaptors for
B1HA 26, 35, 94, 125, B1KA 35, 125,
B2TB 19, 35, 68, 125, B2HA 19, 28, 35,
B2HB 19, 26, 35, 68, 94, 125
B2HA 80, 88, 100, 112, 150, 285, 311, 352, 399, 530

This boiler adaptor is shown (pre-installed) for models
 B1HA 26, 35, 94, 125, B1KA 35, 125,
 B2TB 19, 35, 68, 125, B2HA 19, 28, 35,
 B2HB 19, 26, 35, 68, 94, 125

PP(s) vent component fits directly into the boiler adaptor

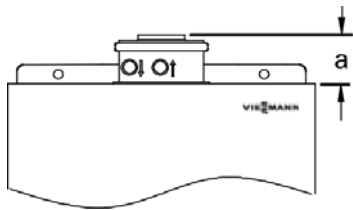

This boiler adaptor is shown (pre-installed) for models
 B2HA 45, 60, B2HB 45, 57, 160, 199, B1HE 85, 120,
 150, 199, B1KE 120, 199, B2HE 85, 120, 150, 199
 PP(s) vent component fits directly into the boiler adaptor

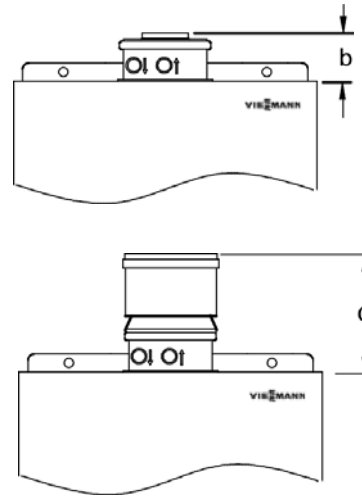

WARNING

(For this type of installation only:)
Boiler comes with pre-installed combustion air cover mounted on the concentric vent pipe adaptor. Do not remove combustion air intake cover. Removing this cover may cause unintended room air dependent operation (non-direct vent). Room air dependent operation requires provision of combustion and ventilation air (as per section "Single Pipe Venting", see page 59.

This boiler adaptor is shown installed with a required transition adaptor for models B2HA 80, 88, 100, 112, 150, 285, 311, 352, 399, 530 (required only if using M&G/DuraVent system).

Centrotherm PP(s) vent component fits directly into the boiler adaptor.

Legend

- a 2 3/4 in. (70 mm)
- b 2 1/2 in. (64 mm)
- c 7 1/2 in. (191 mm)

Side Wall Vent Termination

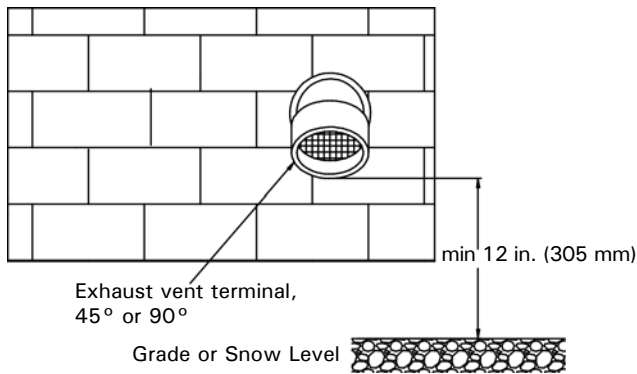

Side wall vent termination (front view)

IMPORTANT

For PP(s) systems, all exhaust vent and air intake piping and elbows exposed outside, must be UV resistant polypropylene (supplied by the vent manufacturer).

IMPORTANT

All PP(s) vent termination elbows, must be secured in place as specified by the manufacturer.

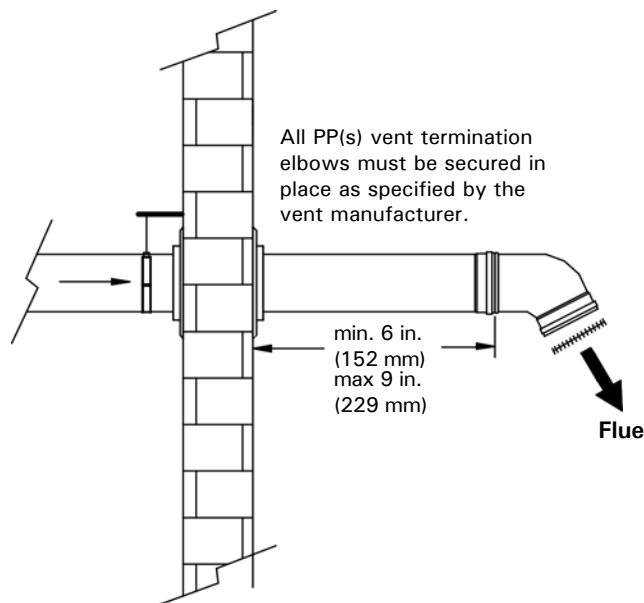

Side wall vent termination (side view)

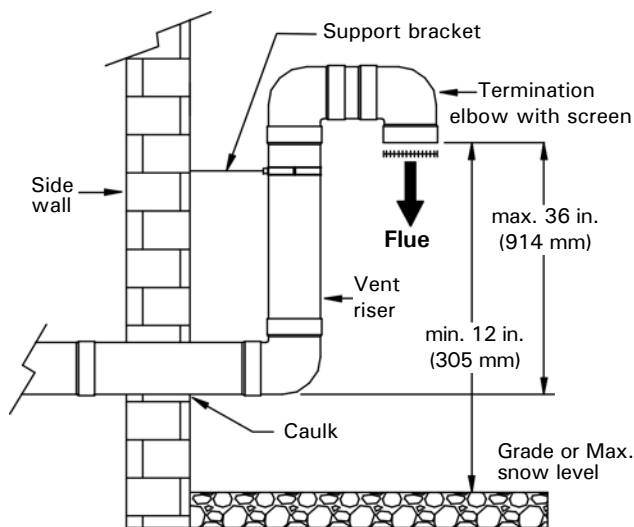

Installation of field fabricated vent riser

Vent Length Requirements

Maximum vent pipe length - horizontal

All PP(s) vent material and air intake (if PP(s) used) must be ULC S636 or UL 1738 listed, manufactured by M&G / DuraVent or Centrotherm InnoFlue.

Size the exhaust vent pipe as specified in the table below. This table lists the maximum allowable vent length in feet and meters of the exhaust piping. Vent diameter must not be reduced at any point in the installation.

Maximum allowable equivalent length - horizontal

Boiler Model	System Ø	Max. equivalent vent length "a"*3
B1HA 26, 35, 94, 125, B1KA 35, 125	2 in. (51 mm)*1	86 ft. (31 m)
	3 in. (76 mm)*2	164 ft. (50 m)
	4 in. (102 mm)*2	200 ft. (61 m)
B1HE 85	2 in. (51 mm)*6	98 ft. (30 m)*7
	3 in. (76 mm)	164 ft. (50 m)
	4 in. (102 mm)*2	198 ft. (60 m)
B1HE 120	2 in. (51 mm)*6	98 ft. (30 m)*8
	3 in. (76 mm)	164 ft. (50 m)
	4 in. (102 mm)*2	198 ft. (60 m)
B1HE 150, 199	3 in. (76 mm)	98 ft. (30 m)
	4 in. (102 mm)*2	148 ft. (45 m)
B1KE 120	2 in. (51 mm)*6	98 ft. (30 m)*8
	3 in. (76 mm)	164 ft. (50 m)
	4 in. (102 mm)*2	198 ft. (60 m)
B1KE 199	3 in. (76 mm)	98 ft. (30 m)
	4 in. (102 mm)*2	148 ft. (45 m)
B2HA 19, 28, 35, B2TA 19, 35, B2HB 19, 26, 35, 68, 94, 125, B2TB 19, 35, 68, 125	2 in. (51 mm)*1	115 ft. (35 m)
	3 in. (76 mm)*2	148 ft. (45 m)
	4 in. (102 mm)*2	180 ft. (55 m)
B2HA 45, 60, B2HB 45, 57, 68, 94	3 in. (76 mm)	98 ft. (30 m)
	4 in. (102 mm)*2	148 ft. (45 m)
B2HA 80, 88, 100, 112, 285, 311, 352, 399	4 in. (102 mm)	131 ft. (40 m)
B2HA 150, 530	4 in. (100 mm)*4	131 ft. (40 m)
	5 in. (125 mm)*5	131 ft. (40 m)
B2HE 85	2 in. (51 mm)*6	98 ft. (30 m)*7
	3 in. (76 mm)	164 ft. (50 m)
	4 in. (102 mm)*2	198 ft. (60 m)
B2HE 120	2 in. (51 mm)*6	98 ft. (30 m)*8
	3 in. (76 mm)	164 ft. (50 m)
	4 in. (102 mm)*2	198 ft. (60 m)
B2HE 150, 199	3 in. (76 mm)	98 ft. (30 m)
	4 in. (102 mm)*2	148 ft. (45 m)

*1 2 in. diameter system only available with CPVC / PP(s) system

*2 4 in. (3 in. to 4 in. increaser field supplied).

*3 See illustration below.

*4 Due to higher exhaust vent pipe resistance, there is an automatic input reduction of 9% for model B2HA 150 when a 4 inch diameter vent pipe is used.

*5 4 in. to 5 in. increaser field supplied.

*6 3 in. to 2 in. reducer required field supplied.

*7 There is an automatic input reduction of 2%.

*8 There is an automatic input reduction of 5%.

IMPORTANT

First elbow not included in equivalent vent calculation.
Always include vent termination length in calculations.

Vent Length Requirements *(continued)*

Minimum vent length is 3.3 ft. (1 m).

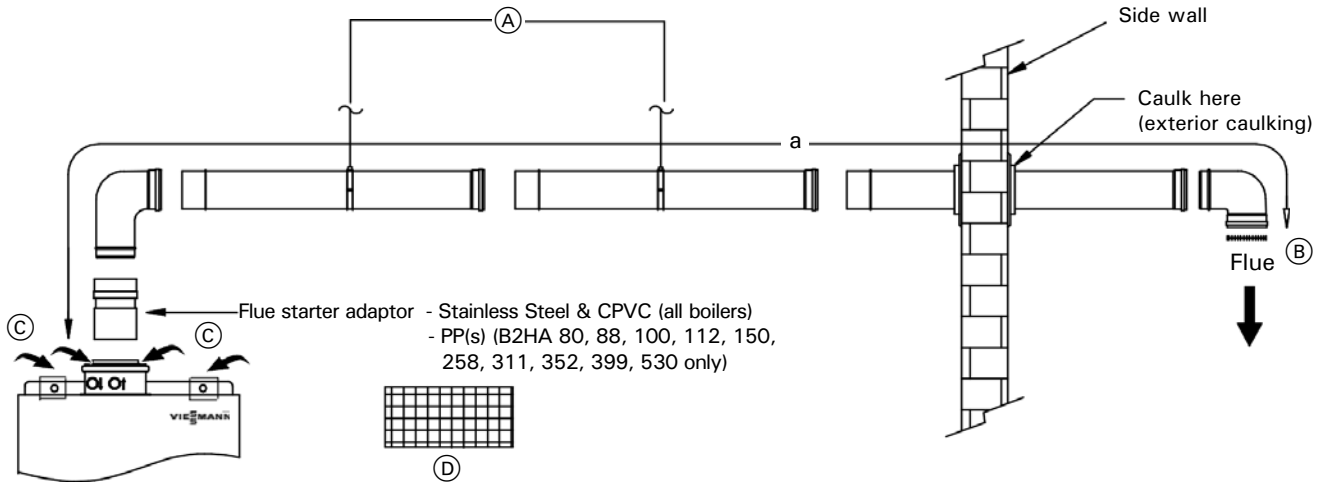

Legend

- (A) Support system
- (B) Exhaust vent termination
- (C) Combustion air intake [left (not available for B1HA/B1KA), right or through co-axial opening], remove and discard air intake cover (B1HA 26, 35, 94, 125, B1KA 35, 125, B2TB 19, 35, 68, 125, B2HA 19, 28, 35, B2HB 19, 26, 35, 68, 94, 125) B1HE 85, 120, 150, 199 B1KE 120, 199, B2HE 85, 120, 150, 199
- (D) Combustion air opening
- a Equivalent vent length (exhaust)

- Vitodens 100-W B1HA 26, 35, 94, 125, B1KA 35, 125
- Vitodens 222-F B2TB 19, 35, 68, 125
- Vitodens 200-W B2HA 19, 28, 35,
- Vitodens 200-W B2HB 19, 26, 35, 68, 94, 125
- Vitodens 100-W B1HE 85, 120, 150, 199
- Vitodens 100-W B1KE 120, 199
- Vitodens 200-W B2HE 85, 120, 150, 199

IMPORTANT

For PP(s) systems, all exhaust vent and air intake piping and elbows exposed outside, must be UV resistant polypropylene (supplied by the vent manufacturer).

Vent Length Requirements *(continued)***Maximum vent pipe length - vertical**

All PP(s) vent material and air intake (if PP(s) used) must be ULC S636 or UL 1738 listed, manufactured by M&G / DuraVent or Centrotherm InnoFlue.

Size the exhaust vent pipe as specified in table below. This table lists the maximum allowable vent length in feet and meters of the exhaust piping. Vent diameter must not be reduced at any point in the installation.

IMPORTANT

For PP(s) systems, all exhaust vent and air intake piping and elbows exposed outside, must be UV resistant polypropylene (supplied by the vent manufacturer).

Maximum allowable equivalent length - vertical

Boiler Model	System Ø	Max. equivalent vent length "a"*3
B1HA 26, 35, 94, 125, B1KA 35, 125	2 in. (51 mm)*1	86 ft. (31 m)
	3 in. (76 mm)*2	164 ft. (50 m)
	4 in. (102 mm)*2	200 ft. (61 m)
B1HE 85	2 in. (51 mm)*6	98 ft. (30 m)*7
	3 in. (76 mm)	164 ft. (50 m)
	4 in. (102 mm)*2	198 ft. (60 m)
B1HE 120	2 in. (51 mm)*6	98 ft. (30 m)*8
	3 in. (76 mm)	164 ft. (50 m)
	4 in. (102 mm)*2	198 ft. (60 m)
B1HE 150, 199	3 in. (76 mm)	98 ft. 30 m)
	4 in. (102 mm)*2	148 ft. (45 m)
B1KE 120	2 in. (51 mm)*6	98 ft. (30 m)*8
	3 in. (76 mm)	164 ft. (50 m)
	4 in. (102 mm)*2	198 ft. (60 m)
B1KE 199	3 in. (76 mm)	98 ft. 30 m)
	4 in. (102 mm)*2	148 ft. (45 m)
B2HA 19, 28, 35, B2HB 19, 26, 35, 68, 94, 125, B2TB 19, 35, 68, 94	2 in. (51 mm)*1	115 ft. (35 m)
	3 in. (76 mm)*2	148 ft. (45 m)
	4 in. (102 mm)*2	180 ft. (55 m)
B2HA 45, 60, B2HB 45, 57, 160, 199	3 in. (76 mm)	98 ft. (30 m)
	4 in. (102 mm)*2	148 ft. (45 m)
B2HA 80, 88, 100, 112, 285, 311, 352, 399 B2HA 150, 530	4 in. (102 mm)	131 ft. (40 m)
	4 in. (100 mm)*4 5 in. (125 mm)*5	131 ft. (40 m) 131 ft. (40 m)
B2HE 85	2 in. (51 mm)*6	98 ft. (30 m)*7
	3 in. (76 mm)	164 ft. (50 m)
	4 in. (102 mm)*2	198 ft. (60 m)
B2HE 120	2 in. (51 mm)*6	98 ft. (30 m)*8
	3 in. (76 mm)	164 ft. (50 m)
	4 in. (102 mm)*2	198 ft. (60 m)
B2HE 150, 199	3 in. (76 mm)	98 ft. 30 m)
	4 in. (102 mm)*2	148 ft. (45 m)

*1 2 in. diameter system only available with CPVC / PP(s) systems

*2 4 in. (3 in. to 4 in. increaser field supplied).

*3 See illustration below.

*4 Due to higher exhaust vent pipe resistance, there is an automatic input reduction of 9% for model B2HA 150, 530 when a 4 inch diameter vent pipe is used.

*5 4 in. to 5 in. increaser field supplied.

*6 3 in. to 2 in. reducer required field supplied.

*7 There is an automatic input reduction of 2%.

*8 There is an automatic input reduction of 5%.

Vent Length Requirements *(continued)*

Minimum vent length is 3.3 ft. (1 m.)

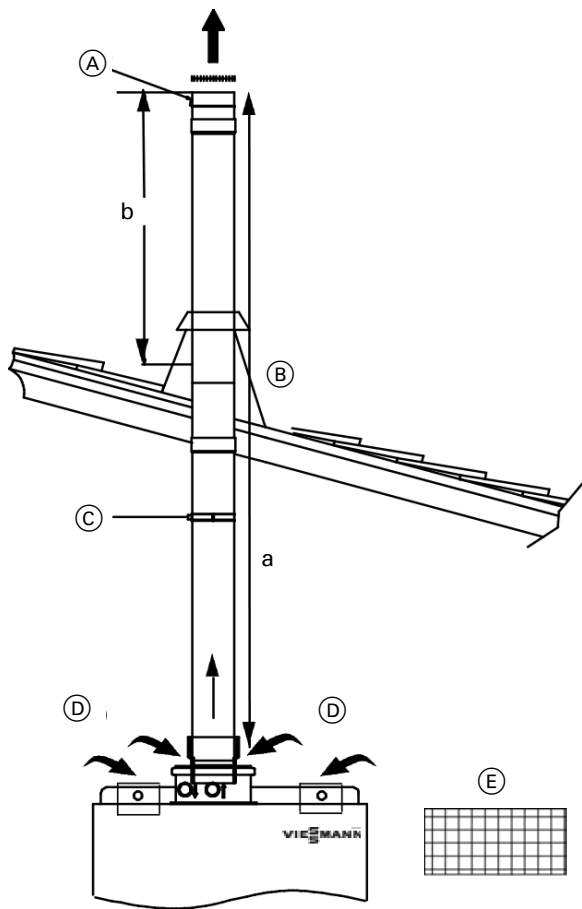

Legend

- (A) Exhaust (straight coupling) with screen
- (B) Flashings
- (C) Support system
- (D) Combustion air intake [left (not available for B1HA/B1KA), right or through co-axial opening], remove and discard air intake cover (B1HA 26, 35, 94, 125, B1KA 35, 125, B2TB 19, 35, 68, 125, B2HA 19, 28, 35, B2HB 19, 26, 35, 68, 94, 125) B1HE 85, 120, 150, 199 B1KE 120, 199, B2HE 85, 120, 150, 199
- (E) Combustion air opening
- a Equivalent length (exhaust)
- b min. 18 in. (457 mm)
max. 48 in. (1219 mm)

Component Installation Guide

General single-pipe vertical venting layout

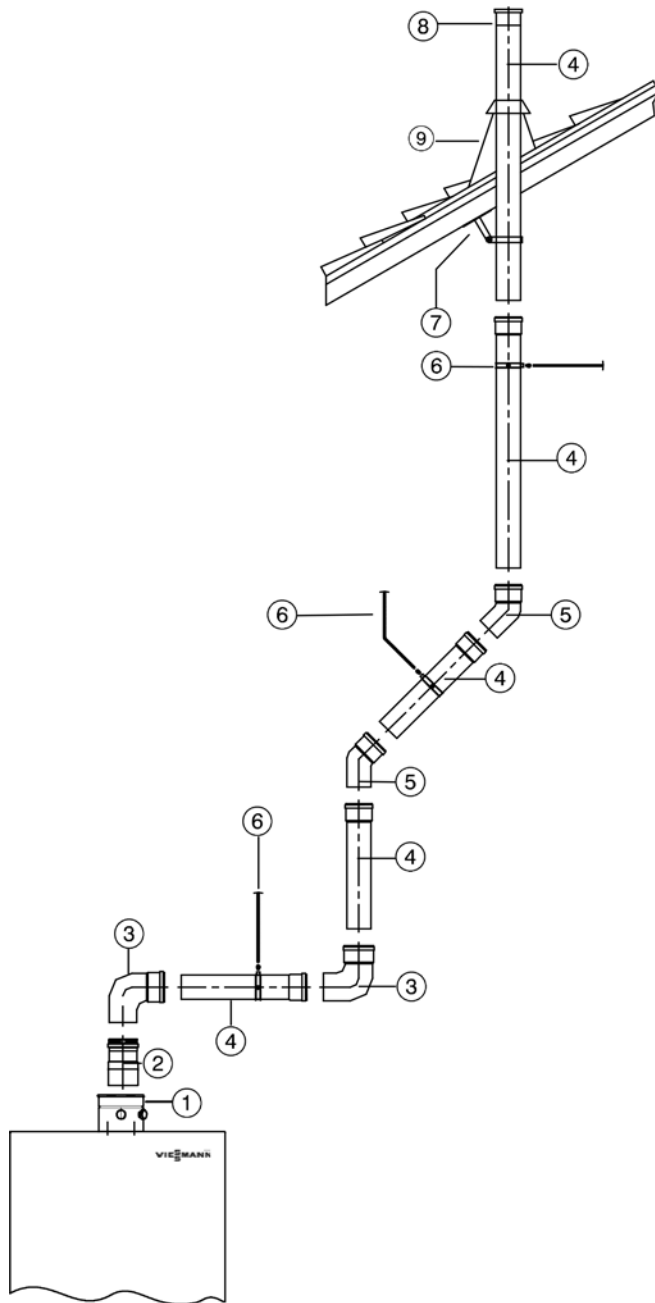

Legend

- ① Coaxial vent pipe adaptor (comes pre-installed on Vitodens boilers)
- ② Vent pipe starter adaptor (if required)
- ③ Elbow, 90°
- ④ Straight pipe * 1
- ⑤ Elbow, 45°
- ⑥ Suspension band / hanger
- ⑦ Wall band
- ⑧ Vent termination coupling (with bird screen)
- ⑨ Flashing and storm collar

* 1 Available in different lengths.

For more detailed information on component parts see product literature supplied by special venting manufacturer.

IMPORTANT

Ensure that the venting system is properly supported. See pages 27 and 73 for details.

Vent pipe starter adaptor is not required for PP(s) venting system (except for B2HA 80, 88, 100, 112, 150, 285, 311, 352, 399, 530 see page 77).

Component Installation Guide *(continued)*

Single-pipe vent starter adaptor installation

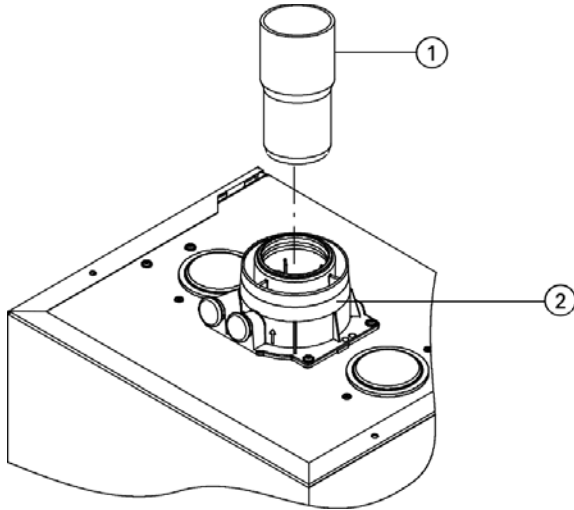

Installing single-pipe vent adaptor for stainless steel and CPVC (not required for PP(s) vent system)

- Vitodens 100-W B1HA 26, 35, 94, 125, B1KA 35, 125, 222-F B2TB 19, 35, 68, 125 and 200-W B2HA 19, 28, 35, B2HB 19, 26, 35, 68, 94, 125
- B1HE 85, 120, 150, 199
- B1KE 120, 199
- B2HE 85, 120, 150, 199

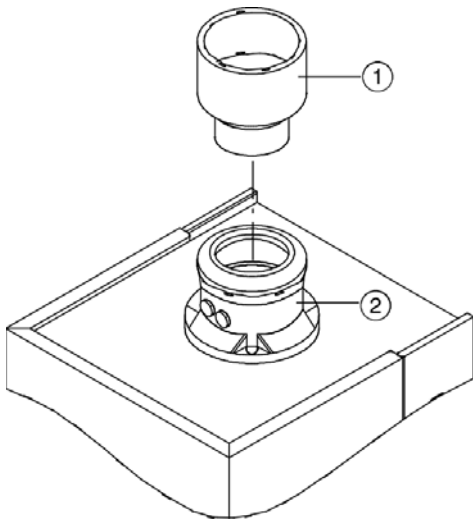

- Vitodens 200-W B2HA 45, 60, 80, 88, 100, 112, 150, 285, 311, 352, 399, 530
- B2HB 45, 57, 160, 199

Installing single-pipe vent adaptor for stainless steel and CPVC vent systems [not required for PP(s)]
 For PP(s) vent system, see page 70.

! WARNING

Prior to installation, ensure the specially designed single-pipe vent adaptor end is smooth and chamfered to prevent possible damage to the sealing gasket of the boiler vent pipe adaptor (coaxial). Failure to comply could result in leakage, potentially causing personal injury or death.

1. Apply small amount of water to end of single-pipe vent adaptor to ease insertion.
2. Slide special single-pipe vent adaptor ① fully onto boiler vent pipe adaptor ② . Do not apply excessive force and/or bend single-pipe vent adaptor ① when inserting. Force could damage gasket.

IMPORTANT

The boiler vent pipe adaptor comes pre-installed for all Vitodens 100-W, 222-F and 200-W boilers.

Ceiling/Roof opening

Cut an opening for the vent pipe.

Size opening at least 1 in. (25 mm) larger than vent pipe diameter (for combustible as well as non-combustible material).

Component Installation Guide *(continued)*

2 inch Single Pipe Venting Systems
(B1HE/B1KE 85/120, B2HE 85/120)

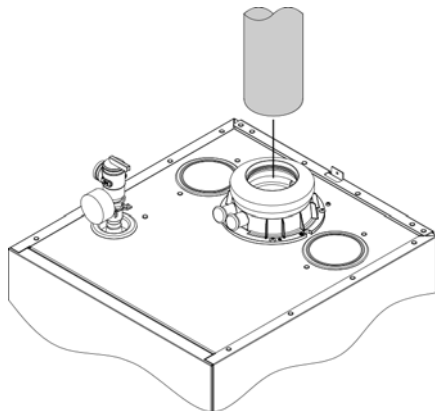

IMPORTANT

Do not install the Coaxial vent seal, and do not remove the center portion of the combustion air pipe gaskets.

System Components
CPVC Venting Material

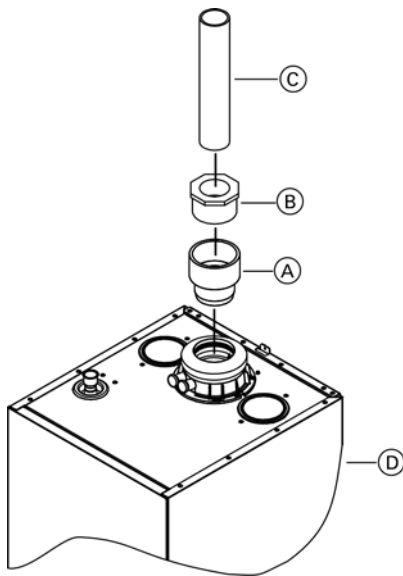

Legend

- (A) CPVC Vent Adaptor 80 mm to 3 in. (Viessmann PN 7134 770)
- (B) CPVC Reducing Bushing 3 inch to 2 in.
- (C) CPVC Venting Material 2 in.
- (D) Vitodens 100 B1HE/KE 85/120
Vitodens 200 B2HE 85/120

PPs Venting Material

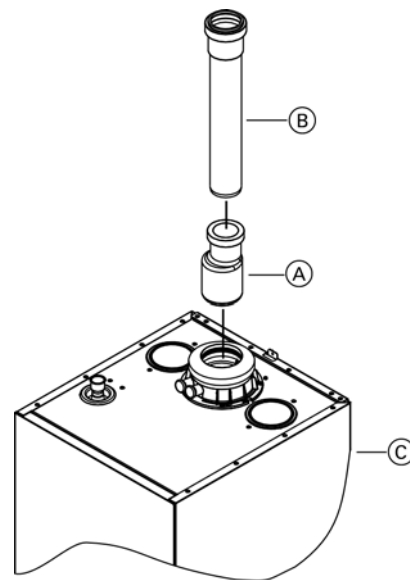

Legend

- (A) PPs Reducer 80 mm to 60 mm
- (B) PPs Venting Material 60 mm (2 3/8 in.)
- (C) Vitodens 100 B1HE/KE 85/120
Vitodens 200 B2HE 85/120

Component Installation Guide *(continued)*

Equivalent vent length calculation example - vertical

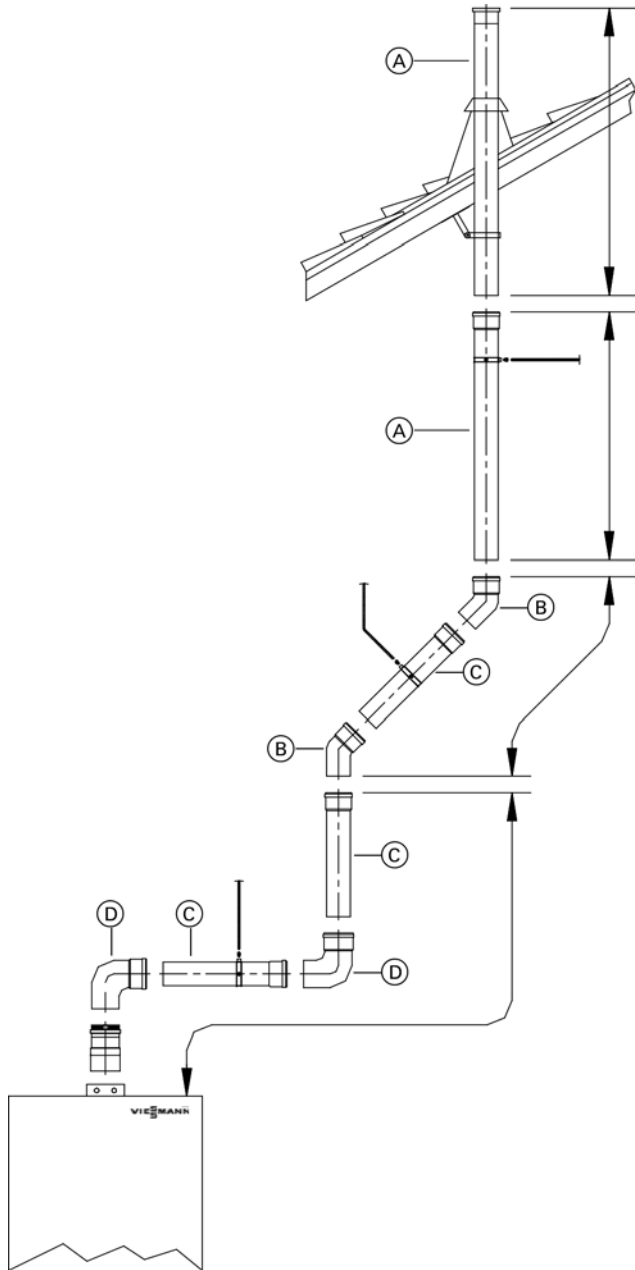

Equivalent vent length calculation example

Equivalent vent length calculation example (stainless steel system)

Vitodens 100-W, B1HA 26, 35, 94, 125 or
B1KA 35, 125 or 222-F B2TB 19, 35, 68, 125 or 200-W
B2HA 19, 28, 35 or B2HB 19, 26, 35, 68, 94, 125

2 x 90° elbow.....	6 ft. (1.8 m)
2 x 45° elbow.....	4 ft. (1.2 m)
3 x vent pipe (0.5 m).....	4.9 ft. (1.5 m)
2 x vent pipe (1 m).....	6.6 ft. (2 m)
Total equivalent length.....	21.5 ft. (6.5 m)

Above example will change as follows if using CPVC venting system (first 90° elbows are not included):

2 x 90° elbow.....	10 ft. (3.1 m)
2 x 45° elbow.....	6 ft. (1.8 m)
3 x vent pipe (0.5 m).....	4.9 ft. (1.5 m)
2 x vent pipe (1 m).....	6.6 ft. (2 m)
Total equivalent length.....	27.5 ft. (8.4 m)

Type of fitting	Equivalent length
90° long sweep elbow (CPVC)	5 ft. (1.52 m)
45° long sweep elbow (CPVC)	3 ft. (0.91 m)

Equivalent lengths of venting components may vary between vent manufacturers, use manufacturers values when calculating vent system equivalent lengths.

Note: See also table on page 52.

Legend

- Ⓐ Vent pipe 3.3 ft. (1 m)
- Ⓑ 45° elbow
- Ⓒ Vent pipe 1.6 ft. (0.5 m)
- Ⓓ 90° elbow

Component Installation Guide *(continued)*

Single-pipe vent termination installation

Install the vent termination coupling, along with the bird screen, for sloped or flat roof collars in accordance with the manufacturer’s instructions.

General installation examples - vertical

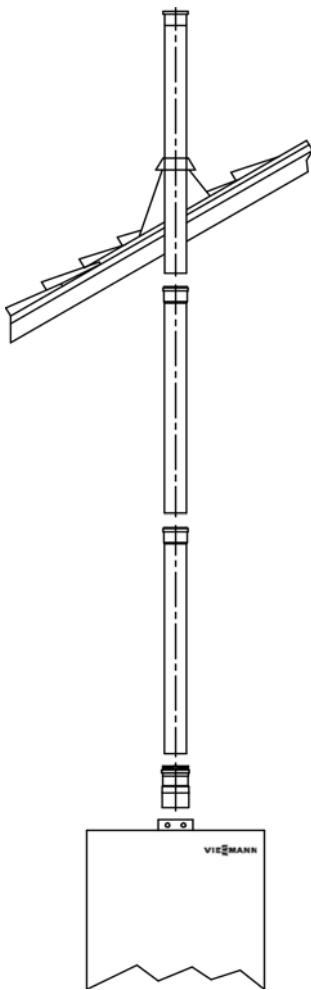

Sloped roof installation

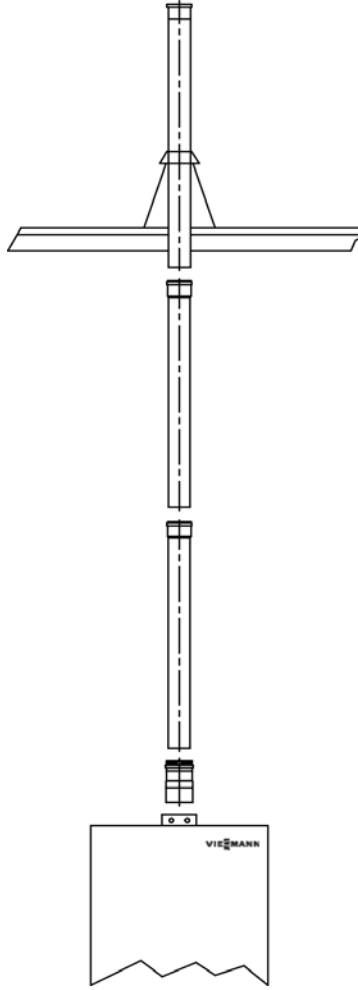

Flat roof installation

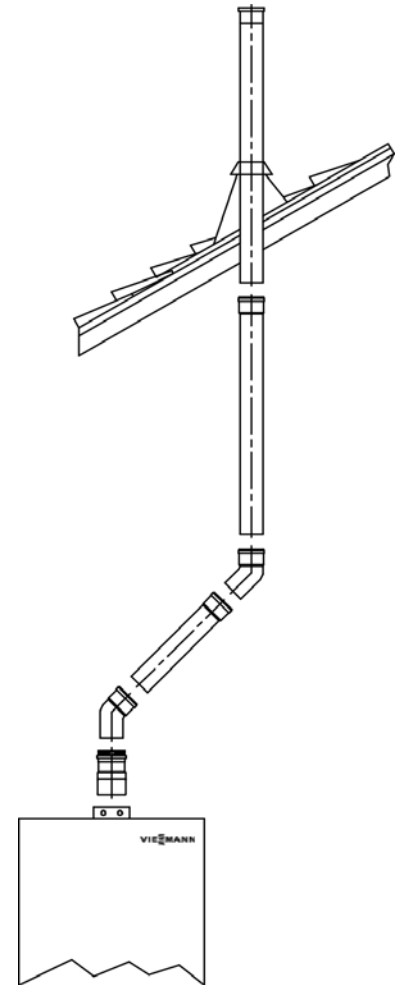

Sloped roof installation with offset

IMPORTANT

Ensure that the venting system is properly supported; the Vitodens boiler is not designed to support the weight of the venting system.

Vent Termination Spacing

Multiple boiler installations (vertical termination with multiple boilers)

When terminating the vertical vent pipes of multiple Vitodens boilers, a minimum clearance of 4 inches (100 mm) is required between the outside edges of each vent pipe.

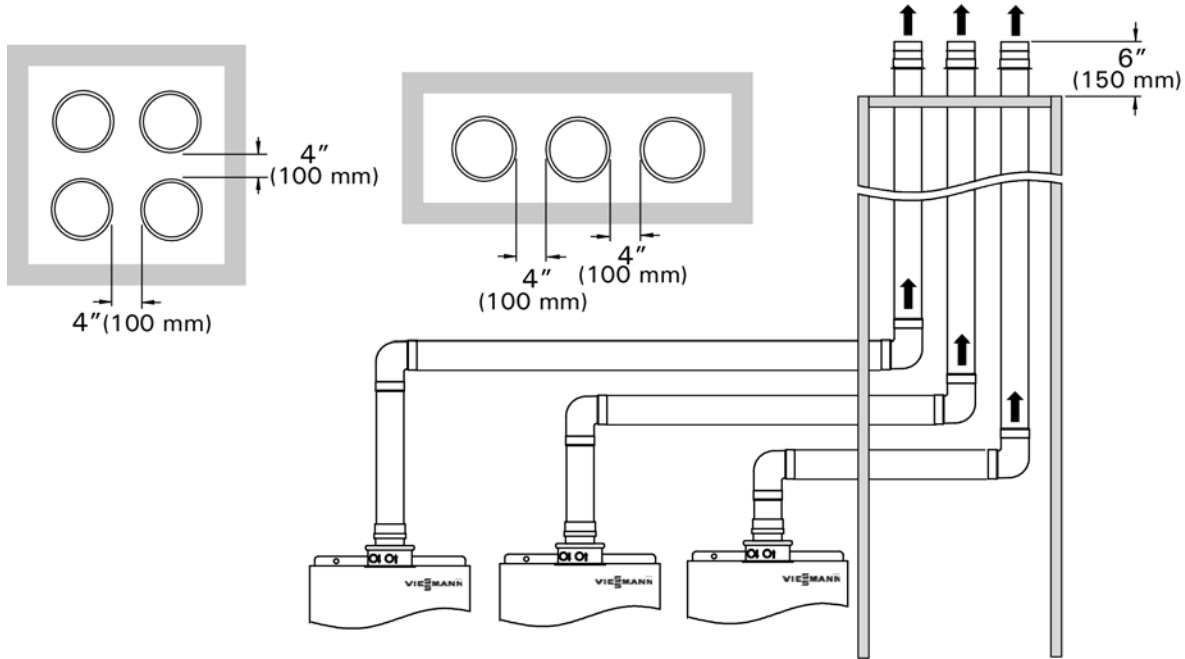

Multiple boiler installations (horizontal termination with multiple boilers)

When terminating the horizontal vent pipes of multiple Vitodens boilers, a minimum clearance of 12 inches (305 mm) is required between the outside edges of each vent pipe.

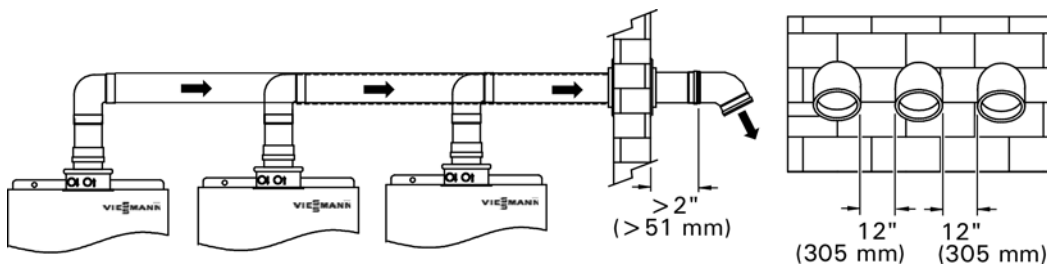

Note: termination elbows can be 45° or 90°.

Installation of Support System - PP(s)

The venting system must be securely supported by a support system suitable for the weight and design of the materials employed. Contact your vent material supplier for more information specific to your installation.

Supports

Supports are used to transfer the weight of an installation to the building structure. There are different types of supports and their capacity varies with each type and diameter.

The following support types are available at your local vent material supplier...

- anchor plate
- wall support
- roof support
- floor support
- suspension band (hanger).

In addition to the support types listed above Viessmann offers mounting clips which can be used in conjunction with the above support types to support the weight of the venting system. Please contact Viessmann to order.

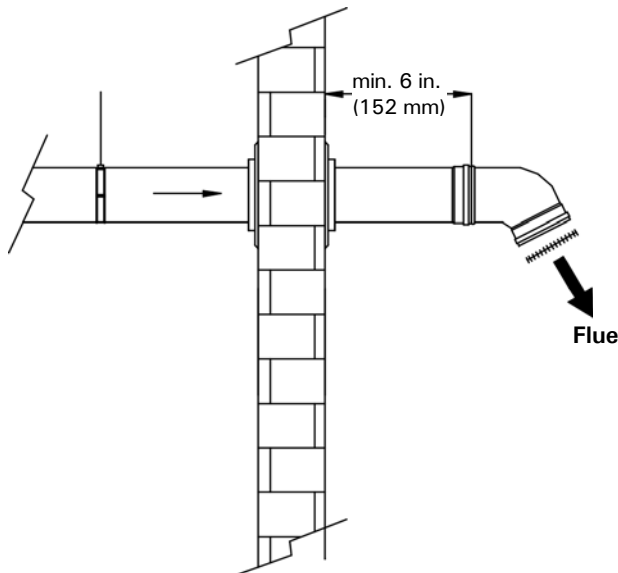

IMPORTANT

For PP(s) systems, all exhaust vent and air intake piping and elbows exposed outside, must be UV resistant polypropylene (supplied by the vent manufacturer).

Bracing

Contact your local vent material supplier for more information specific to your installation.

Braces are required to stabilize an installation. There are different types and their use and spacing vary.

The following types of braces are available at your local vent material supplier...

- wall band
- wall band extension
- guy wire band
- roof brace.

IMPORTANT

Ensure that the venting system is properly supported; the Vitodens boiler is not designed to support the weight of the venting system.

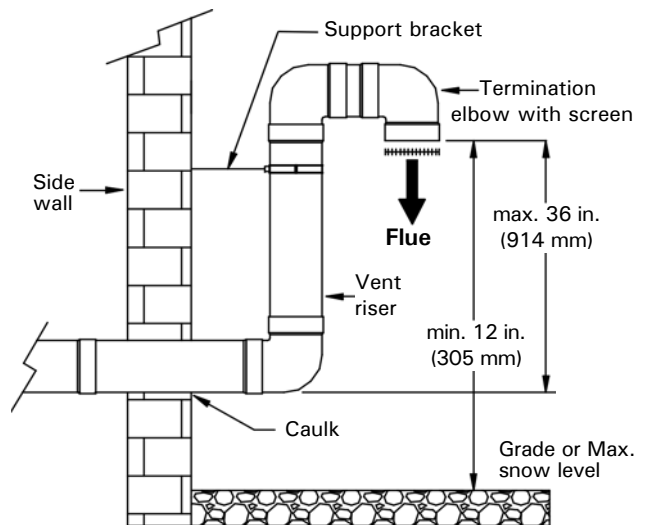

Installation of field fabricated vent riser

General Flex Venting Installation

Exhaust vent installation steps

! WARNING

Ensure that the entire venting system is protected from physical damages. A damaged venting system may cause unsafe conditions.

! WARNING

The venting system is approved for indoor installations only. Do not install the venting system outdoors.

The flexible pipes, rigid pipes and components are made from polypropylene material with excellent resistance to flue gas condensate formed in the exhaust vent of a gas-fired condensing heating boiler.

Every venting system must be properly planned and installed for optimum performance and safety. A flexible pipe installation always begins with an inspection of the existing masonry chimney (if being installed in a chimney as a liner). Inspect the masonry chimney for proper construction and compliance with applicable building codes.

A thorough cleaning of the chimney should be done prior to the installation of the chimney liner to ensure that it is free and clear of obstructions. Should an inspection reveal that an existing chimney is not safe for the intended application, it must be repaired or rebuilt to conform to NFPA 211 or any other applicable standards.

- Make sure you have available manpower in order to handle the flexible pipe.
- Determine the proposed location of the opening in the existing chimney. The slope of the connecting rigid flue pipe should be a minimum of 2-3° [approximately to 2 in. per 3.3 ft. (50 mm per 1 m)].
- The length of the flexible vent system can be determined two ways: use a plumb line to measure the existing chimney length (add an extra 16 in. (40 cm) for each bend). The flexible vent system can be shortened by cutting with a saw or scissors within a groove. The correct length can also be determined after installing it in the existing chimney by cutting the flex pipe at the top of the chimney.
- Two lengths of the flexible vent system can be connected to each other with a flex pipe coupling (if required). See manufacturer's catalogue.
- Mount the spacer cross with a maximum distance of 6½ ft. (2 m) apart or as specified by the manufacturer.

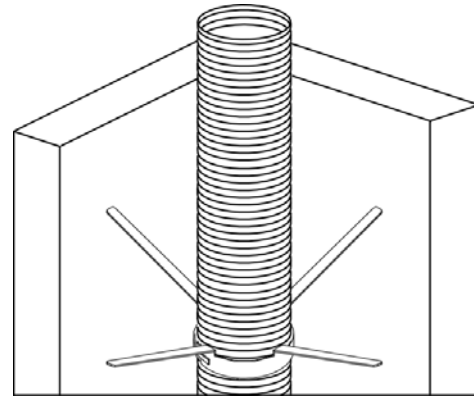

- Some installations may require the use of a rope connected to a pulling cone or directly to the bottom connector.
- With the adaptor and spacers connected, start installing the flex pipe from the top of the chimney and carefully feed the liner down through the middle. To prevent damage to the flex pipe additional manpower may be required to guide the flex pipe with a rope from the bottom of the chimney.

General Flex Venting Installation *(continued)*

Exhaust vent installation steps (continued)

- Once the bottom of the flex pipe and adaptor has reached the desired position, insert into the support elbow/support strip assembly.

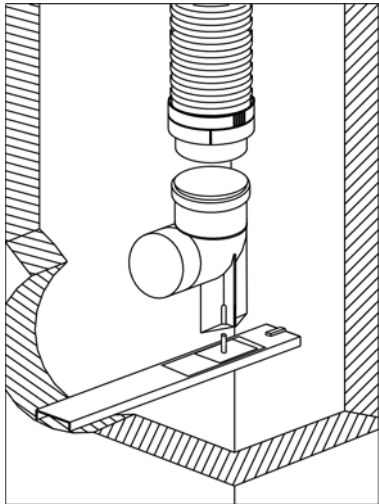

- Choose the required size and install the galvanized wall sleeve (cut to the width of the wall if required) and seal the space between the sleeve and the wall with mortar.

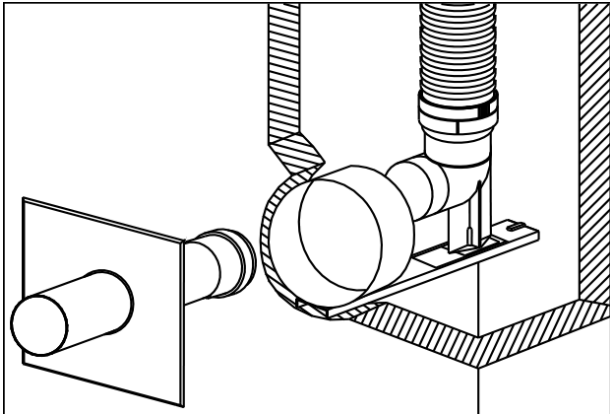

- Proceed with installing the rigid pipes and wall plate. Start from the chimney support elbow to the boiler adaptors (rigid pipes can be cut to the correct length if required).
- Seal the top wall of the chimney with a water resistant sealant.

IMPORTANT

When cutting rigid pipes to length, debur and clean pipes.

- For flexible vent systems:
In conjunction with these instructions, follow the installation instructions supplied by the special venting manufacturer.

Recommended venting practice

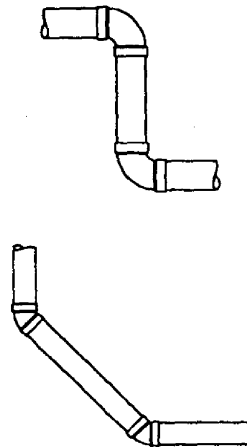

When installing a venting system the following recommended venting practices apply:

- Keep length and number of 90° elbows to a minimum.
- Try not to use back-to-back 90° elbows.
- Use 45° elbows where possible to minimize the number of 90° elbows in case redirection of flue gas is required.

Ceiling / roof opening

Cut an opening for the vent pipe. Size opening at least 1 in. (25 mm) larger than vent pipe diameter (for combustible as well as non-combustible material).

General Flex Venting Installation *(continued)*

Approved combustion air intake materials for two-pipe system

Part	Material	Certified to Standards	Applicability
Combustion air intake pipe and fitting	Stainless steel	n.a.	U.S.A./Canada
	PVC-DWV Schedule 40	ANSI/ASTM D2661 CSA B181.1 ULC S102.2 ANSI/ASTM D2665, D1785 CSA B137.3, B181.2 ANSI/ASTM F441	
	CPVC Schedule 40	ANSI/ASTM D2661 CSA B181.1 ULC S102.2 ANSI/ASTM D2665, D1785 CSA B137.3, B181.2 ANSI/ASTM F441	
	ABS-DWV Schedule 40	ANSI/ASTM D2661 CSA B181.1 ULC S102.2 ANSI/ASTM D2665, D1785 CSA B137.3, B181.2 ANSI/ASTM F441	
Pipe cement, primer (for combustion air intake pipe)	PVC	ANSI/ASTM D2564 CSA B137.3	
	CPVC	ANSI/ASTM F493 CSA B137.6	
	ABS	ANSI/ASTM D2235 CSA B181.1/B182.1	

Note: Always use latest edition of applicable standard

⚠ CAUTION
Do not use cellular (foam) core pipe material to vent this Vitodens boiler.

⚠ CAUTION
Do not use PVC material in exhaust system.

⚠ CAUTION
On the job site, ensure that non-listed combustion air pipe materials are not inadvertently used instead of listed vent pipe material.

Exhaust Vent Requirements

The Vitodens 100-W, 200-W and 222-F boilers must be located in such a way that the vent length is as short as possible and that the vent can be routed as directly (and with as few bends) as possible.

See pages 94 for maximum vent lengths.

All products of combustion must be safely vented to the outdoors.

The Vitodens boiler is not approved for common-venting applications. Do not common-vent with any other boiler. The Vitodens boiler vents under positive pressure and is a Category IV boiler.

WARNING

Failure to ensure that all flue gases have been safely vented to the outdoors can cause property damage, severe personal injury, or loss of life. Flue gases may contain deadly carbon monoxide.

Viessmann recommends that the entire vent system be checked by a licensed professional heating contractor at least once each year following initial installation.

WARNING

Different manufacturers offer a number of different joint systems and adhesives. Do not mix pipes, fittings and/or joining methods from different manufacturers. Failure to comply could result in leakage, potentially causing personal injury or death.

Do not install vent pipe in a way that flue gases flow downwards. The direction of flue gas flow must be vertically upwards or horizontal with an upward slope.

Ensure there is no flue gas leakage into the area in which the boiler is installed.

Check proper location of gaskets in rigid PP(s) pipe collars. (Only use supplied parts with the polypropylene venting system).

Apply water (or lubricant supplied with the venting system) to lubricate the joint ends of the vent pipe collar and if used, the air intake pipe collar.

Slide pipes into each other with a gentle twisting motion.

Check joints for leaks with the gas supply turned off and the fan running. Use a soapy solution to check for vent leaks.

Condensate must drain from the flue pipe to the boiler. Ensure a suitable gradient of at least 2°-3° based on the vent manufacturer's system design [example: for a 3° system approx. 2 in. per 3.3 ft. (50 mm per 1 m) on any horizontal venting components].

No condensate trap is required in the vent pipe system.

If exhaust vent pipe system passes through an unheated space, such as an attic, it must be insulated. The insulation must have an R value sufficient to prevent freezing of the condensate. Armaflex insulation with ½ in. thickness and higher can be used.

The connection between the boiler and the base of the flexible pipe is made with rigid vent components (flexible pipe cannot be run directly to the boiler).

The flexible pipe can only be used in vertical installations.

Direct venting (two-pipe system) or single pipe (room air independent) is acceptable (refer to page 97 for combustion air requirements for room air dependent installations).

For direct venting applications the air intake pipe can be installed through the sidewall or vertical through the roof.

Any increaser used in the exhaust vent/air intake pipe must be installed in the vertical position.

The remaining space surrounding a chimney liner, gas vent, or special gas vent or plastic piping installed within a masonry, metal or factory-built flue shall not be used to supply combustion air (a separate combustion air pipe routed back to the boiler can be used in the remaining space if required).

Vent system suppliers

Use special venting system (UL/ULC listed for Category IV) for exhaust vent material of the Vitodens boilers. Contact one of the following suppliers to order parts.

All manufacturers deliver PP(s) rigid and flexible vents the required sizes.

2 in. (60 mm)	2 in. (60 mm)
3 in. (80 mm)	3 in. (80 mm)
4 in. (100 mm)	4.3 in. (110 mm)
M&G / Duravent www.duravent.com	Centrotherm InnoFlue www.centrotherm.us.com
PolyFlue - Selkirk www.polyflue.com	ECCO Manufacturing www.eccomfg.com
Z-FLEX US Inc. NovaFlex Group www.novaflex.com	

Combustion Air Supply

The Vitodens boiler is suitable for vertical venting using rigid pipe and flexible pipe vent system material. The Vitodens 100-W, 200-W and 222-F boilers are approved for both direct vent (sealed combustion), as well as direct exhaust (non-sealed combustion) operation in vertical arrangements. For non-sealed combustion vent systems (i.e. room-air dependent), see appropriate section under "Single Pipe Venting" starting on page 97 in this manual.

The boiler must be connected to a direct vent system in which all air for combustion is taken from the outside atmosphere and all combustion products are discharged safely to the outdoors.

The boiler must be vented and supplied with combustion air and exhaust vent as described in this section. Ensure the vent and combustion air supply comply with these instructions.



CAUTION

Do not locate boiler in areas where high dust levels or high humidity levels are present.



CAUTION

Do not install boiler during construction involving drywall or heavy dust of any kind. Dust can accumulate in the burners and cause sooting. Install boiler after all heavy dust construction is completed.

* Typically when the boiler is used as a temporary heat source during the building construction phase.

Inspect all finished exhaust vent/air intake piping to ensure:

- Vent/air intake pipe and fittings are of approved material.
- Acceptable size, length and number of elbows on combined vent/air intake system.
- Installation is in accordance with prevailing provisions of local codes.
- Installation complies with the requirements of these instructions, as well as the exhaust vent/air intake supplier's instructions.

The exhaust vent and combustion air intake system and terminations may be installed in one of the following type terminations (2-pipe system):

1. Vertical air intake and exhaust vent pipes.
2. Horizontal air intake pipe and vertical exhaust vent pipe.

If there is moisture or high humidity existing in the room where the combustion air intake is installed, condensation formation on the inlet pipe may occur. Either a type 'B' (insulated) pipe or an insulated inlet pipe may be used.



CAUTION

If the boiler has been exposed to high dust levels, all burners and the heat exchanger must be cleaned prior to use.



CAUTION

If above criteria are not properly observed and boiler damage results, any warranty on the complete boiler and related components will be null and void.

Starter Adaptor

Vent pipe starter adaptors for B1HA 26, 35, 94, 125, B1KA 35, 125, B2HA 19, 28, 35, B2HB 19, 26, 35, 68, 94, 125, B2TB 19, 35, 68, 125,

Note: This adaptor (A) may not be required, contact vent manufacturer for available vent sizes.

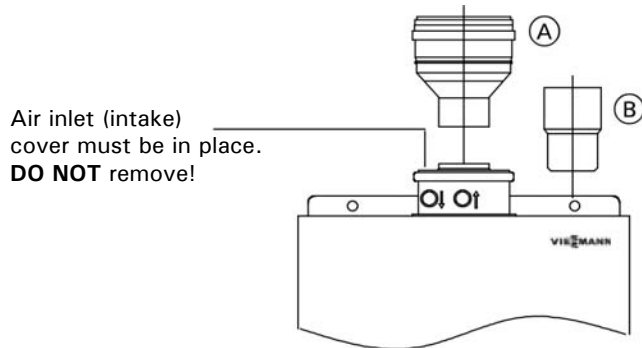

WARNING

(For this type of installation only:)

Boiler comes with pre-installed combustion air cover mounted on the concentric vent pipe adaptor. Do not remove combustion air intake cover. Removing this cover may cause unintended room air dependent operation (non-direct vent). Room air dependent operation requires provision of combustion and ventilation air (as per section "Single Pipe Venting", page 97.

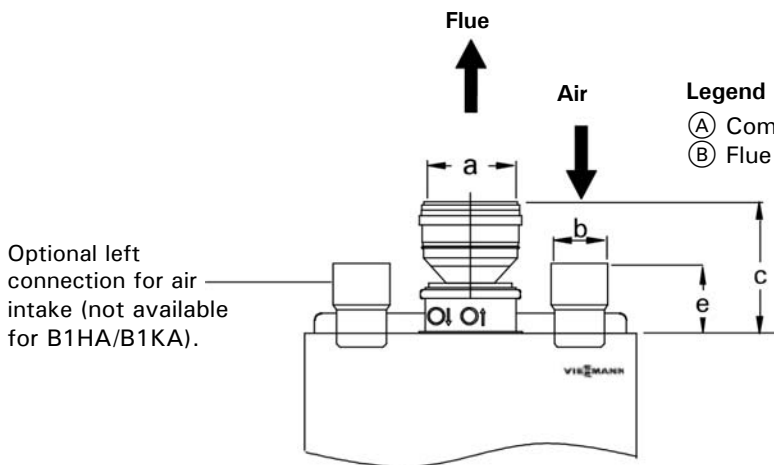
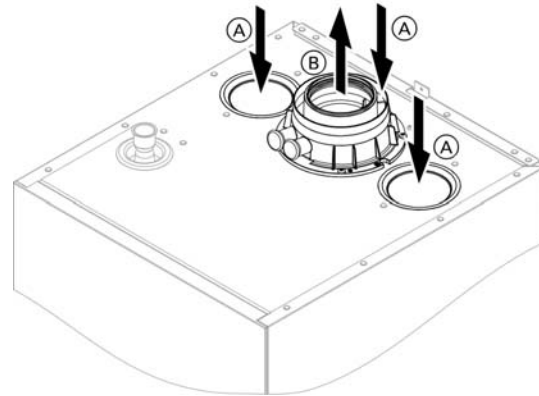

Legend

- (A) Combustion air
- (B) Flue gas

Legend

- (A) PP(s) slip joint vent starter adaptor (60 to 80 mm) *1
- (B) 2 in. CVPC starter adaptor, ViPN 7134 769
- a 3 in. (80 mm) nominal
- b 2 in. (50 mm)
- c 5½ in. (140 mm)
- e 3 in. (80 mm)

*1 For system Ø of 4 in. (100 mm), an increaser adaptor 3 to 4 in. (80 to 100 mm) in addition to this increaser adaptor must be used.

When utilizing the combustion air inlet seal for Vitodens 100 WB1B, B1HA, B1KA, Vitodens 200 B2HA/B and Vitodens 222 B2TB series boilers, remove the inlet seal, tear out center section and install the remaining rubber seal back into the air inlet opening.

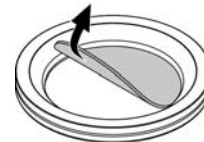

for Vitodens 100 series, 200 B2HA/B and 222 B2TB boilers

Starter Adaptor

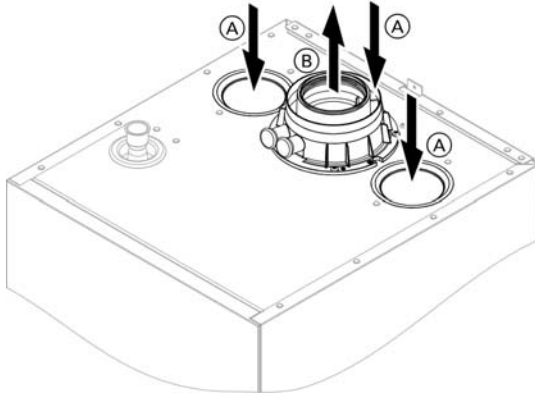

Legend

- (A) Combustion air
- (B) Flue gas

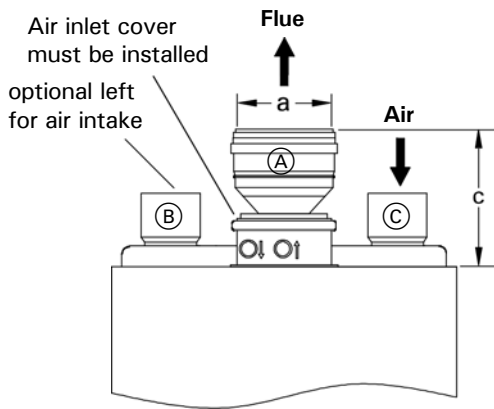

Legend

- (A) 80 mm PP(s) venting system component*1
- (B) 3 in. (80 mm) PP(s) combustion air piping
- (C) 3 in. CPVC/ABS/PVC combustion air piping
- a 3 in. (76 mm)
- c 5½ in. (140 mm)

*1 For system Ø of 4 in. (100 mm), an increaser adaptor 3 to 4 in. (80 to 100 mm) in addition to this increaser adaptor must be used.

! WARNING

The boiler comes with an accessory combustion air cover for the concentric vent pipe adaptor. For direct vent two pipe systems this cover must be installed. Failure to install this cover may result in unintended room air dependent operation (non-direct vent). Room air dependent operation requires provisions of combustion and ventilation air (as per section 'Single Pipe Venting' on page 97).

Vent pipe starter adaptors for;
 B1HE 85, 120, 150, 199
 B1KE 120, 199
 B2HE 85, 120, 150, 199

IMPORTANT

The combustion air gaskets located at the sides of the coaxial vent pipe adaptor are designed to accept combustion air directly without the need for a starter adaptor. These gaskets are not the same size. Only remove the center portion of the gasket required for the combustion air pipe material being used. If necessary the position of the gasket can be switched on the boiler from left to right or vice versa. In factory position PPs connection gasket is installed on the left, CVPC/ABS/PVC installed on the right.

Parallel Adaptor

Parallel adaptor for two-pipe system

Supplier	Boiler Model	Ø in. (mm)	Quantity
Viessmann or Centrotherm InnoFlue	<ul style="list-style-type: none"> ■ B2HA 45, 60 ■ B2HB 45, 57, 160, 199 	3 (80) (see 'a' in illustration below)	1
Viessmann	<ul style="list-style-type: none"> ■ B2HA 80, 88, 100, 112, 150, 285, 311, 352, 399, 530 	4 (110) (see 'a' in illustration below)	1

Parallel vent pipe starter adaptors for B2HA 45, 60, 80, 88, 100, 112, 150, 285, 311, 352, 399, 530, B2HB 45, 57, 160, 199

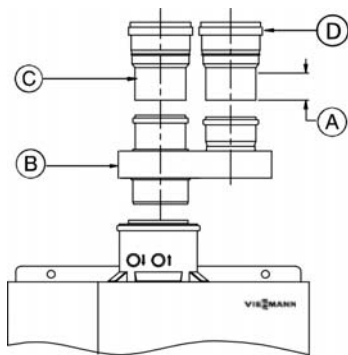

Legend

for B2HA 45, 60, B2HB 45, 57, 160, 199

- Ⓐ Air intake, max. insertion 2½ in. (64 mm)
- Ⓑ Viessmann or Centrotherm parallel adaptor
- Ⓒ Used only on B2HA 80, 88, 100, 112, 150, 285, 311, 352, 399, 530
- Ⓓ Viessmann CPVC adaptor
- a 3 in. (80 mm)
- b 2¾ in. (70 mm)
- c 7 in. (178 mm)
- d Approx. 10¾ in. (271 mm)
- e 4¾ in. (120 mm)

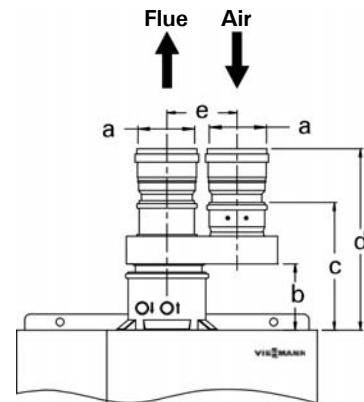

Legend

for B2HA 80, 88, 100, 112, 150, 285, 311, 352, 399, 530

- Ⓐ Air intake, max. insertion 2½ in. (64 mm)
- Ⓑ Viessmann parallel adaptor
- Ⓒ Slip joint vent starter / transition adaptor 4⅝ to 4 in. (110 to 100 mm) only required if M&G / Duravent system is used
- Ⓓ Viessmann CPVC adaptor
- a 4 in. (100 mm)
- b 5⅛ in. (130 mm)
- c 9⅜ in. (237 mm)
- d 12⅞ in. (327 mm)
- e 5½ in. (140 mm)

Vent Requirements - Flexible Vent System / Connector Pipes

Additional requirements for flexible vent system / connector pipe vent material

Exhaust vent/air intake connection to boiler

The vent/air intake connection to the Vitodens boiler must be made according to the table below. The starter adaptors are intended for a slip fit and slide into the parallel adaptor or boiler adaptor with a gentle twisting motion.

For air intake pipe system, one wire mesh screens (bird screen) must be ordered from Viessmann. These parts are available in pre-cut diameters of 2 in., 3 in. and 4 in.

Note: The Vitodens boiler has passed the zero inches vent clearance to combustibles testing requirements dictated by the Harmonized Standard ANSI Z21.13. CSA 4.9. and therefore is listed for zero clearance to combustibles when vented with a single pipe special venting system.

 **WARNING**

The use of vent material other than listed flexible PP(s), positive pressure vent pipe and fittings can cause property damage, severe personal injury and/or loss of life.

Required starter adaptors for CPVC air intake system / PPs vent system

Part	Boiler Model	Diameter	Supplier	Quantity
Parallel Pipe Adaptor	B2HA 45,60 B2HB 45, 57, 160, 199 B2HA 80, 88, 100, 112, 150, 285, 311, 352, 399, 530	3 in. (80 mm) 3 in. (80 mm) 4 in. (100 mm)	Viessmann	1
CPVC Starter Adaptor for Air Intake	B1HA 26, 35, 94, 125 B1KA 35, 125 B2HA 19, 28, 35 B2HB 19, 26, 35, 68, 94, 125 B2TB 19, 35, 68, 125 B2HA 45, 60 B2HB 45, 57, 68, 94 B2HA 80, 88,100, 112, 150, 285, 311, 352, 399, 530	2 in. (50 mm) 2 in. (50 mm) 2 in. (50 mm) 2 in. (50 mm) 2 in. (50 mm) 3 in. (80 mm) 3 in. (80 mm) 4 in. (100 mm)	Viessmann	1
Wire Mesh Screen for Air Intake Termination	B1HA 26, 35, 94, 125 B1KA 35, 125 B2HA 19, 28, 35 B2HB 19, 26, 35, 68, 94, 125 B2TB 19, 35, 68, 125 B2HA 45, 60 B2HB 45, 57, 160, 199 B2HA 80, 88, 100, 112, 150, 285, 311, 352, 399, 530 B1HE 85, 120, 150, 199 B1KE 120, 199 B2HE 85, 120, 150, 199	2 in. (50 mm) 2 in. (50 mm) 3 in. (80 mm), 4 in. (100 mm) if used 3 in. (80 mm), 4 in. (100 mm) if used 3 in. (80 mm), 4 in. (100 mm) if used 3 in. (80 mm) 3 in. (80 mm) 4 in. (100 mm) 3 in. (80 mm), 4 in. (100 mm) if used 3 in. (80 mm), 4 in. (100 mm) if used 3 in. (80 mm), 4 in. (100 mm) if used	Viessmann	1
Increaser Adaptor for Exhaust Pipe	B2HA 19, 28, 35 B2HB 19, 26, 35, 68, 94, 125 B2TB 19, 35, 68, 125	2½ to 3 in. (60 to 80 mm) 2½ to 3 in. (60 to 80 mm) 2½ to 3 in. (60 to 80 mm)	Field supplied	1
Transition Adaptor	B2HA 80, 88, 100, 112, 150, 285, 311, 352, 399, 530	4¾ to 4 in. (110 to 100 mm)	Field supplied	1

Side Wall Air Intake Termination

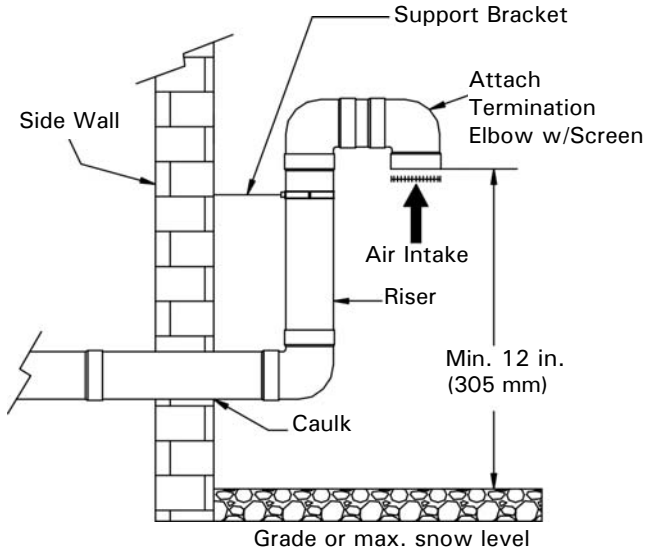

Installation of field fabricated air intake riser (side view)

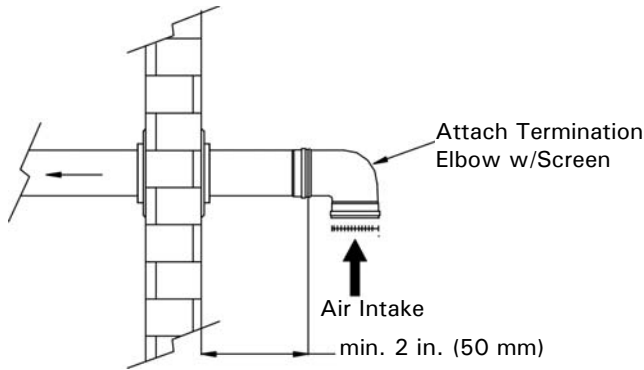

Side wall air intake termination (side view)

IMPORTANT

The air intake system must terminate so that proper clearances are maintained as cited in local codes or the latest edition of the "Natural Gas and Propane Installation Code" CAN/CSA-B149.1 (Canada), or the "National Fuel Gas Code" ANSI Z223.1 (NFPA 54) (U.S.A.). See page 9.

! WARNING

Air intake must be at least 12 in. (300 mm) above the anticipated snow level (consult your local building authorities or local weather office). Locate vent termination in such a way that it cannot be blocked by snow.

Vent Length Requirements

Maximum exhaust vent pipe length vertical and air intake pipe length vertical

Vertical Vent Installation

Vitodens 100-W B1HA 26, 35, 94, 125, B1KA 35, 125
 Vitodens 200-W B2HA 19, 28, 35
 Vitodens 200-W B2HB 19, 26, 35, 68, 94, 125
 Vitodens 222-F B2TB 19, 35, 68, 125
 Vitodens 100-W B1HE 85, 120, 150, 199
 Vitodens 100-W B1KE 120, 199
 Vitodens 200-W B2HE 85, 120, 150, 199

Vertical Vent Installation

Vitodens 200-W B2HA 45, 60, 80, 88, 100, 112, 150, 285, 311, 352, 399, 530, B2HB 45, 57, 160, 199

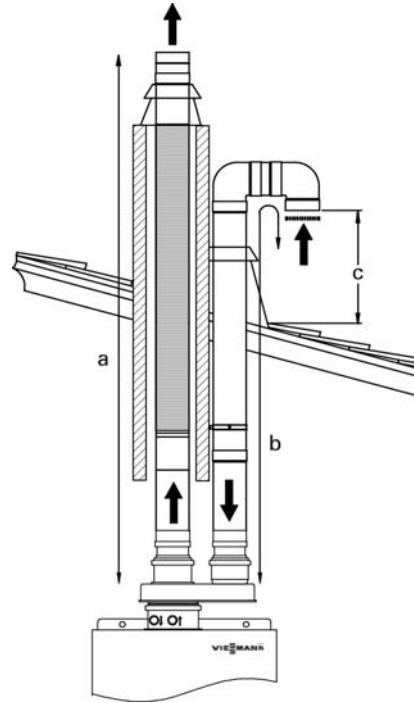
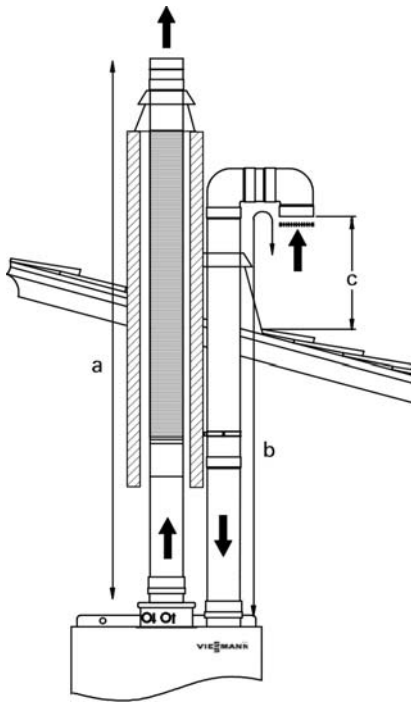

Legend

- a Equivalent length (exhaust)
- b Equivalent length (air intake)
- c 6 in. (152 mm) over max. local snow level
(check with your local weather office for details)

Vent Length Requirements *(continued)*

Maximum allowable equivalent length

Boiler Model	System Ø See note below	Max. combined equivalent vent length (a + b)
B1HA 26, 35, 94, 125, B1KA 35, 125	2 in. (50 mm)	65 ft. (20 m)
	3 in. (80 mm)	123 ft. (37 m)
	4 in. (100 mm)	150 ft. (46 m)
B1HE 85, 120	3 in. (80 mm)	123 ft. (37 m)
	4 in. (100 mm)	148 ft. (45 m)
B1HE 150, 199	3 in. (80 mm)	72 ft. (22 m)
	4 in. (100 mm)	111 ft. (34 m)
B1KE 120	3 in. (80 mm)	123 ft. (37 m)
	4 in. (100 mm)	148 ft. (45 m)
B1KE 199	3 in. (80 mm)	72 ft. (22 m)
	4 in. (100 mm)	111 ft. (34 m)
B2HA 19, 28, 35, B2HB 19, 26, 35, 68, 94, 125 B2TB 19, 35, 68, 125	2 in. (50 mm)	84 ft. (26 m)
	3 in. (80 mm)	111 ft. (34 m)
	4 in. (100 mm)	135 ft. (41 m)
B2HA 45, 60, B2HB 45, 57, 160, 199	3 in. (80 mm)	74 ft. (23 m)
	4 in. (100 mm)	111 ft. (34 m)
B2HA 80, 88, 100, 112, 285, 311, 352, 399	4 in. (100 mm) or 4.3 in. (110 mm)	98 ft. (30 m)
	4 in. (100 mm)*	98 ft. (30 m)
B2HA 150, 530	5 in. (125 mm)**	98 ft. (30 m)
	4 in. (100 mm)	98 ft. (30 m)
B2HE 85, 120	3 in. (80 mm)	123 ft. (37 m)
	4 in. (100 mm)	148 ft. (45 m)
B2HE 150, 199	3 in. (80 mm)	72 ft. (22 m)
	4 in. (100 mm)	111 ft. (34 m)

* Due to higher exhaust vent pipe resistance, there is an automatic input reduction of 9% for model B2HA 150, 530 when a 4 inch diameter vent and air intake pipe are used.

** 4 in. to 5 in. increaser field supplied.

Note: For combination of different vent/air intake pipe diameters, such as Ø 3 in. (80 mm) PP(s) flexible vent with Ø 2 in. (50 mm) CVPC, PVC, ABS air intake pipe, the total equivalent length must be used for the smaller pipe diameter.

Vent Length Requirements *(continued)*

Maximum exhaust vent pipe length vertical and air intake pipe length horizontal

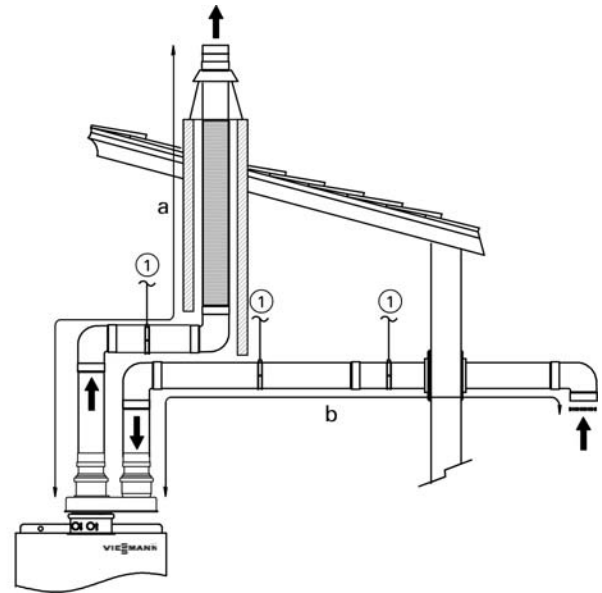
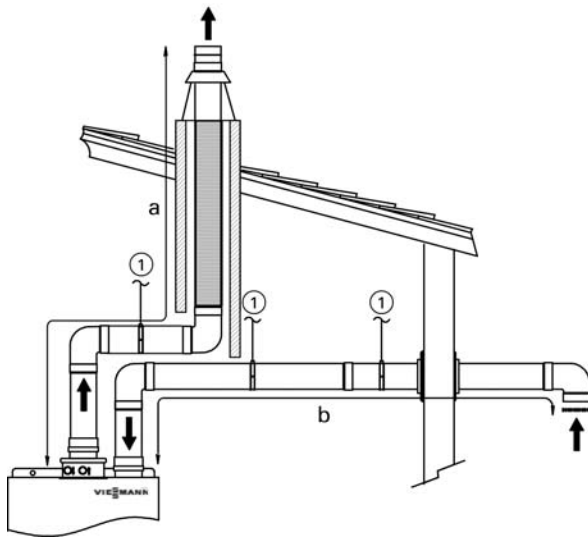

Vitodens 100-W B1HA 26, 35, 94, 125, B1KA 35, 125 and Vitodens 200-W B2HA 19, 28, 35, B2HB 19, 26, 35, 68, 94, 125 and
 Vitodens 222-F B2TB 19, 35, 68, 125
 Vitodens 100-W B1HE 85, 120, 150, 199
 Vitodens 100-W B1KE 120, 199
 Vitodens 200-W B2HE 85, 120, 150, 199

Vitodens 200-W B2HA 45, 60, 80, 88, 100, 112, 150, 285, 311, 352, 399, 530
 B2HB 45, 57, 160, 199

Legend

- a Equivalent length (exhaust)
- b Equivalent length (air intake)

Note: must be 6 in. (152 mm) over max. local snow level (check with your local weather office for details)

① Pipe support

Vent Length Requirements *(continued)*

Maximum allowable equivalent length

Boiler Model	System Ø See note below	Max. combined equivalent vent length (a + b)
B1HA 26, 35, 94, 125, B1KA 35, 125	2 in. (50 mm) 3 in. (80 mm) 4 in. (100 mm)	65 ft. (20 m) 123 ft. (37 m) 150 ft. (46 m)
B1HE 85, 120	3 in. (80 mm) 4 in. (100 mm)	123 ft. (37 m) 148 ft. (45 m)
B1HE 150, 199	3 in. (80 mm) 4 in. (100 mm)	72 ft. (22 m) 111 ft. (34 m)
B1KE 120	3 in. (80 mm) 4 in. (100 mm)	123 ft. (37 m) 148 ft. (45 m)
B1KE 199	3 in. (80 mm) 4 in. (100 mm)	72 ft. (22 m) 111 ft. (34 m)
B2HA 19, 28, 35 B2HB 19, 26, 35, 68, 94, 125 B2TB 19, 35, 68, 125	2 in. (50 mm) 3 in. (80 mm) 4 in. (100 mm)	84 ft. (26 m) 111 ft. (34 m) 135 ft. (41 m)
B2HA 45, 60, B2HB 45, 57, 160, 199	3 in. (80 mm) 4 in. (100 mm)	74 ft. (23 m) 111 ft. (34 m)
B2HA 80, 88, 100, 112, 285, 311, 352, 399	4 in. (100 mm) or 4.3 in. (110 mm)	98 ft. (30 m)
B2HA 150, 530	4 in. (100 mm)* 5 in. (125 mm)**	98 ft. (30 m) 98 ft. (30 m)
B2HE 85, 120	3 in. (80 mm) 4 in. (100 mm)	123 ft. (37 m) 148 ft. (45 m)
B2HE 150, 199	3 in. (80 mm) 4 in. (100 mm)	72 ft. (22 m) 111 ft. (34 m)

* Due to higher exhaust vent pipe resistance, there is an automatic input reduction of 9% for model B2HA 150, 530 when a 4 inch diameter vent and air intake pipe are used.

** 4 in. to 5 in. increaser field supplied.

Note: For combination of different vent/air intake pipe diameters, such as Ø 3 in. (Ø 80 mm) PP(s) flexible vent with Ø 2 in. (Ø 50 mm) CVPC, PVC, ABS air intake pipe, the total equivalent length must be used for the smaller pipe diameter.

Standard elbows (for CPVC / PVC / ABS pipes air intake use only)

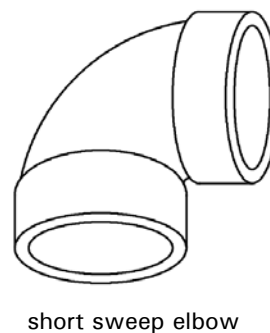
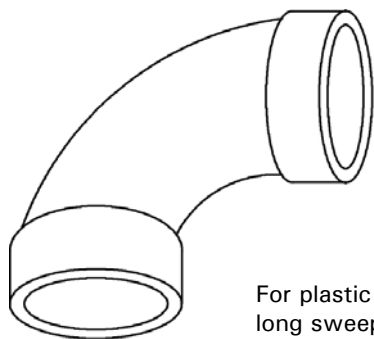

Standard elbows

Material	short 90° elbow equivalent length ft. (m)	long 90° elbow equivalent length ft. (m)	long 45° elbow equivalent length ft. (m)	short 87° elbow equivalent length ft. (m)	long 87° elbow / 87° inspection tee ft. (m)
CPVC plastic pipe	8 (2.4)	5 (1.5)	3 (0.9)	--	-
PP(s)	--	--	3 (0.9)	8 (2.4)	5 (1.5)

Equivalent lengths of venting components may vary between vent manufacturers, use manufacturers values when calculating vent system equivalent lengths.

Combustion Air Supply

The boiler used in this application requires fresh air for safe operation and must be installed in a mechanical room where there are provisions for adequate combustion and ventilation air.

There are no provisions available on the Vitodens boiler to interlock it with an external combustion air blower.

The Vitodens boiler is suitable for vertical venting using flexible venting system material. The Vitodens 100-W and 200-W boilers are approved for direct exhaust (non-sealed combustion) operation in vertical arrangements only.

Provisions for combustion and ventilation air must be made in accordance with CAN/CSA-B149.1 or .2 Natural Gas Installation Codes (for installations in Canada) or in accordance with sections for Combustion and Ventilation Air, of the National Fuel Gas Code, ANSI Z223.1 or applicable provisions of local codes (for installations in the U.S.A.) Always use latest edition of applicable standard.

Follow local codes to properly isolate the vent pipe when passing through floors, ceilings and roof.

Whenever possible, install boiler near an outside wall so that it is easy to duct fresh air directly to the boiler area. Refer to national codes for duct sizing. Round ducts may be used.

The boiler must be vented and supplied with combustion air and exhaust vents as described in this section. Ensure the vent and combustion air supply comply with these instructions.

WARNING

Failure to provide an adequate supply of fresh combustion air can cause poisonous flue gases to enter living space, which can cause severe personal injury or loss of life.

The boiler location should never be under negative pressure. Exhaust fans, attic fans, or dryer fans may cause air to be exhausted at a rate higher than the air can enter the structure for safe combustion. Corrective action must be taken to ensure enough air is available. Never cover the boiler or store debris or other materials near the boiler, or in any way block the flow of adequate fresh combustion air to the boiler.

You must know the free area of louvers used to cover up the combustion and ventilation openings in closet installations. If you do not know the free area, assume 20% for wood louvers and 60 - 75% free area for metal louvers. When using louvers, the openings have to be made larger. For example, a free 14 in. x 6 in. (356 mm x 152 mm) opening becomes a 14 in. x 10 in. (356 mm x 254 mm) opening for a grill containing metal louvers.

CAUTION

Do not store chemicals containing chlorine or other corrosive materials near the boiler, such as bleach, cleaning solvents, detergents, acids, hair spray, spray cans, paint thinners, paint, water softener salt, perchloroethylene, or carbon tetra chloride.

Inspect all finished exhaust vent/air intake piping to ensure:

- Vent pipe and fittings are of approved material.
- Acceptable size, length and number of elbows on combined vent pipe system.
- Installation is in accordance with prevailing provisions of local codes.
- Installation complies with the requirements of these instructions, as well as the exhaust vent supplier's instructions.

The exhaust vent system and terminations may be installed in the vertical exhaust vent type of termination.

CAUTION

Exposure to corrosive materials can cause heat exchanger corrosion and failure.

CAUTION

Do not locate boiler in areas where high dust levels or high humidity levels are present.

CAUTION*

Do not install boiler during construction involving drywall or heavy dust of any kind. Dust can accumulate in the burners and cause sooting. Install boiler after all heavy dust construction is completed.

* Typically when the boiler is used as a temporary heat source during the building construction phase.

CAUTION

If the boiler has been exposed to high dust levels, all burners and the heat exchanger must be cleaned prior to use.

Note: If above criteria are not properly observed and boiler damage results, any warranty on the complete boiler and related components will be null and void.

Adaptors

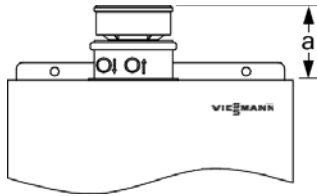

Legend

a 5½ in. (140 mm)

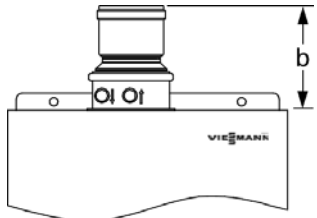

Legend

b 7½ in. (191 mm)

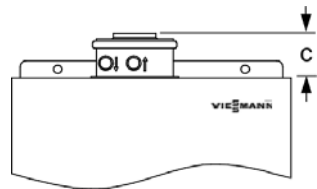

Legend

c 2½ in. (64 mm)

Increaser / transition adaptors

This boiler adaptor is shown installed with an increaser adaptor (if required for 80 mm system) for models B1HA 26, 35, 94, 125, B1KA 35, 125, B2HA 19, 28, 35, B2HB 19, 26, 35, 68, 94, 125 and B2TB 19, 35, 68, 125.

This boiler adaptor is shown installed with a required transition adaptor for models B2HA 80, 88, 100, 112, 150, 285, 311, 352, 399, 530. Required only with M&G / Duravent system.

This boiler adaptor is shown (pre-installed) for models B2HA 45, 60, B2HB 45, 57, 160, 199 B1HE 85, 120, 150, 199 B1KE 120, 199 B2HE 85, 120, 150, 199

The connecting rigid pipe (PPs) fits directly into the boiler adaptor.

Vent Length Requirements

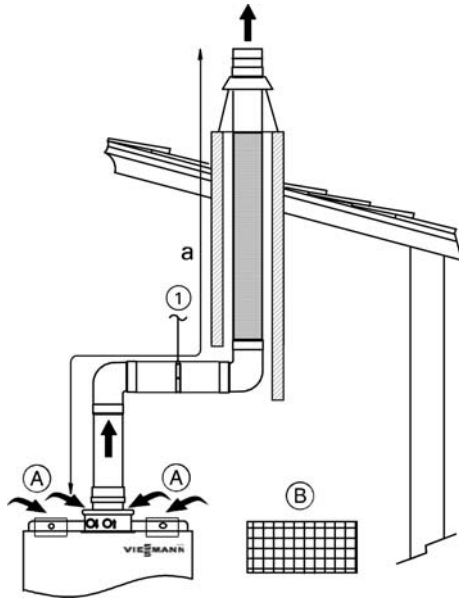

Maximum vent pipe length - vertical

Note: For combination of different vent/air intake pipe diameters, such as Ø 3 in. (80 mm) PP(s) flexible vent with Ø 2 in. (50 mm) CVPC, PVC, ABS air intake pipe, the total equivalent length must be used for the smaller pipe diameter.

Legend

- (A) Combustion air intake (left, right or through co-axial opening), remove and discard air intake cover for B2HA 19, 28, 35, B2HB 19, 26, 35, 68, 94, 125, and B2TB 19, 35, 68, 125)
B1HE 85, 120, 150, 199
B1KE 120, 199
B2HE 85, 120, 150, 199
- (B) Combustion air opening
- a Equivalent vent length (exhaust)
- (1) Pipe support

Maximum allowable equivalent length - vertical

Boiler Model	System Ø See note below	Max. combined equivalent vent length (a + b)
B1HA 26, 35, 94, 125 B1KA 35, 125	2 in. (50 mm) 3 in. (80 mm) 4 in. (100 mm)	65 ft. (20 m) 123 ft. (37 m) 150 ft. (46 m)
B1HE 85, 120	3 in. (80 mm) 4 in. (100 mm)	123 ft. (37 m) 148 ft. (45 m)
B1HE 150, 199	3 in. (80 mm) 4 in. (100 mm)	72 ft. (22 m) 111 ft. (34 m)
B1KE 120	3 in. (80 mm) 4 in. (100 mm)	123 ft. (37 m) 148 ft. (45 m)
B1KE 199	3 in. (80 mm) 4 in. (100 mm)	72 ft. (22 m) 111 ft. (34 m)
B2HA 19, 28, 35 B2HB 19, 26, 35, 68, 94, 125 B2TB 19, 35, 68, 125	2 in. (50 mm) 3 in. (80 mm) 4 in. (100 mm)	84 ft. (26 m) 111 ft. (34 m) 135 ft. (41 m)
B2HA 45, 60, B2HB 45, 57, 160, 199	3 in. (80 mm) 4 in. (100 mm)	74 ft. (23 m) 111 ft. (34 m)
B2HA 80, 88, 100, 112, 285, 311, 352, 399	4 in. (100 mm) or 4.3 in. (110 mm)	98 ft. (30 m)
B2HA 150, 530	4 in. (100 mm)* 5 in. (125 mm)**	98 ft. (30 m) 98 ft. (30 m)
B2HE 85, 120	3 in. (80 mm) 4 in. (100 mm)	123 ft. (37 m) 148 ft. (45 m)
B2HE 150, 199	3 in. (80 mm) 4 in. (100 mm)	72 ft. (22 m) 111 ft. (34 m)

* There is an input reduction of 9% for model B2HA 150, 530 when a 4 in. diameter vent pipe is used.

** 4 in. to 5 in. increaser field supplied.

Component Installation Guide

Single pipe vent pipe starter adaptor installation (if required)

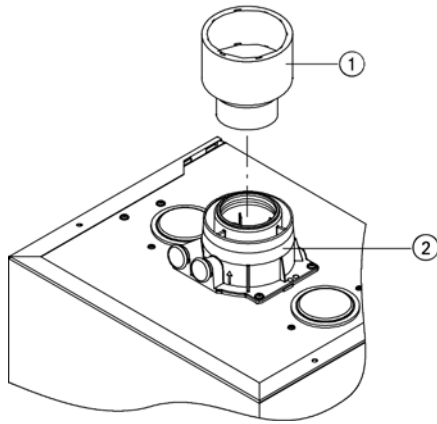

Installing single pipe vent increaser adaptor Vitodens (if required) 100-W B1HA 26, 35, 94, 125, B1KA 35, 125, 200-W B2HA 19, 28, 35, B2HB 19, 26, 35, 68, 94, 125 and 222-F B2TB 19, 35, 68, 125.

Legend

- ① Increaser/transition adaptor
- ② Vent pipe adaptor

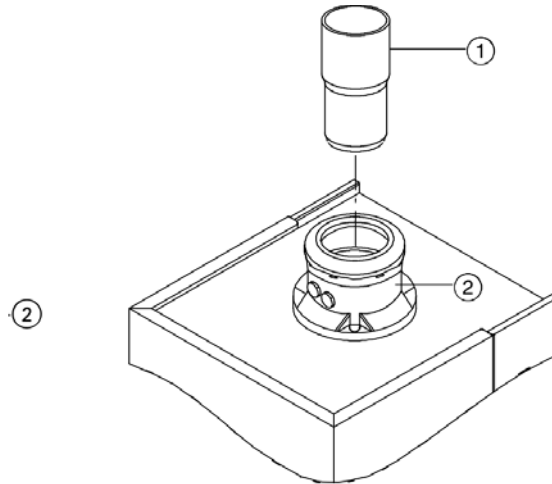

Installing single pipe vent transition adaptor 4¾ to 4 in. (110 to 100 mm) M&G / Duravent only Vitodens 200-W B2HA 80, 88, 100, 112, 150, 285, 311, 352, 399, 530.

Legend

- ① Increaser/transition adaptor
- ② Vent pipe adaptor

! WARNING

Prior to installation, ensure the specially designed single pipe vent adaptor end is smooth and chamfered to prevent possible damage to the sealing gasket of the boiler vent pipe adaptor (coaxial). Failure to comply could result in leakage, potentially causing personal injury or death.

Slide single pipe increaser or transition adaptor ① fully onto boiler vent pipe adaptor ②.

IMPORTANT

The boiler vent pipe adaptor comes pre-installed for all Vitodens 100-W and 200-W boilers.

Required Starter Adaptors

Part	Boiler Model	Diameter	Supplier	Quantity
Increaser Adaptor for Exhaust Vent Pipe (if required)	B1HA 26, 35, 94, 125, B1KA 35, 125 B2HA 19, 28, 35 B2HB 19, 26, 35, 68, 94, 125 B2TB 19, 35, 68, 125	2½ in. to 3 in. (60 mm to 80 mm)	M&G / Duravent or Centrotherm InnoFlue	1
Transition Adaptor for Exhaust Vent Pipe	B2HA 80, 88, 100, 112, 150, 285, 311, 352, 399, 530	4¾ in. to 4 in. (110 mm to 100 mm)	M&G / Duravent	1

General Component Parts of the Flex Venting System

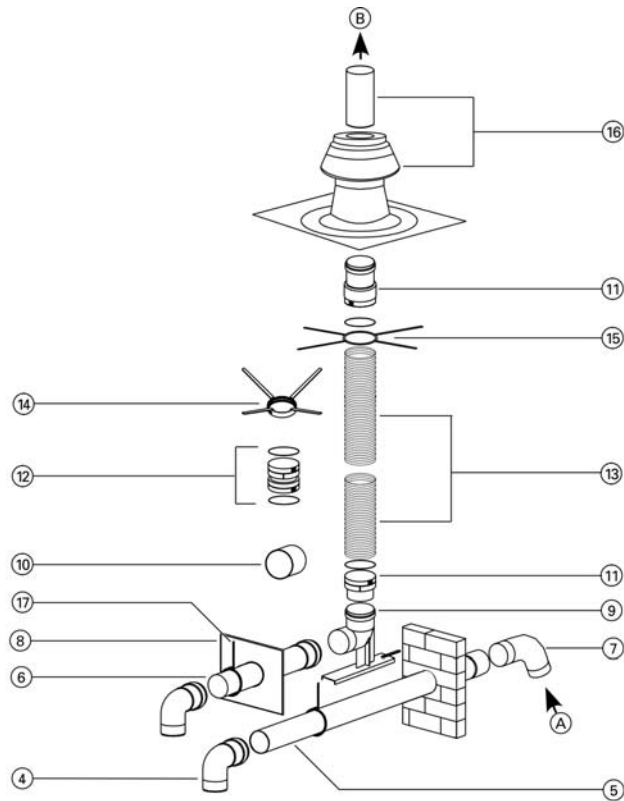

B2HA 45, 60, 80, 88, 100, 112,
150, 285, 311, 352, 399, 530
B2HB 45, 57, 160, 199

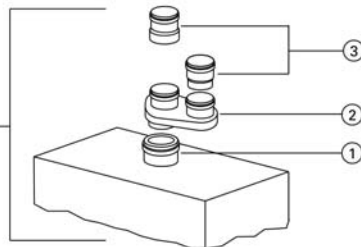

B1HA 26, 35, 94, 125
B1KA 35, 125
B2HA 19, 28, 35
B2HB 19, 26, 35, 68, 94, 125
B1HE 85, 120, 150, 199
B1KE 120, 199
B2HE 85, 120, 150, 199

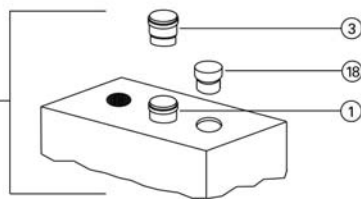

Legend

- (A) Combustion air intake
- (B) Flue gas outlet
- (1) Boiler vent pipe adaptor
- (2) Double-pipe adaptor (used for direct vent system)
- (3) Adaptors
- (4) 90° elbows
- (5) Combustion air intake vent material
- (6) Straight pipe
- (7) Vent termination
- (8) Wall plate
- (9) 90° support elbow
- (10) Wall sleeve
- (11) Adaptor set
- (12) Coupling
- (13) Flex pipe
- (14) Spacer cross
- (15) Support cross
- (16) Chimney cap with termination pipe
- (17) Pipe support (mounting clip)
- (18) Air intake starter adaptor

Two Pipe Options (Direct Vent) (with boiler coaxial adaptor 80/125 with air intake connection)

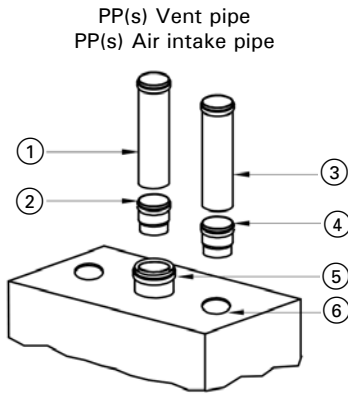

#	Component	Supplied
①	Vent Component	Field
②	Vent increaser (if required) (80 mm to 100 or 110 mm)	Field
③	Air intake component	Field
④	Air intake increaser (if required) (80 mm to 100 or 110 mm)	Field
⑤	Boiler coaxial adaptor (80 mm / 125 mm)	C/W Boiler
⑥	Air intake connection	

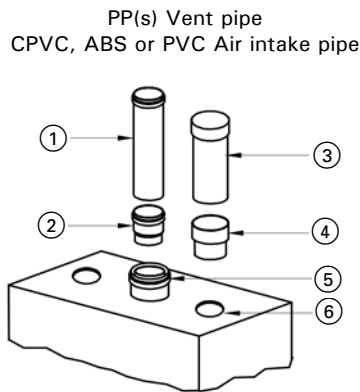

#	Component	Supplied
①	Vent Component	Field
②	Vent increaser (if required) (80 mm to 100 or 110 mm)	Field
③	Air intake component	Field
④	Air intake increaser (if required) (3 in. to 4 in.)	Field
⑤	Boiler coaxial adaptor (80 mm / 125 mm)	C/W Boiler
⑥	Air intake connection	

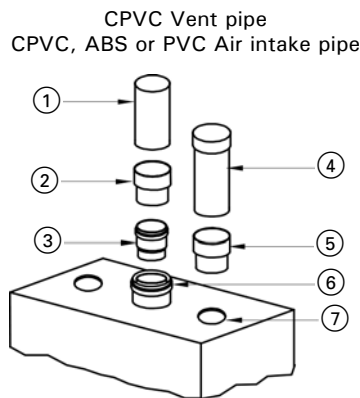

#	Component	Supplied
①	Vent Component	Field
②	Vent increaser (if required) (3 in. to 4 in.)	Field
③	Vent starter adaptor (CPVC), (80 mm to 3 in.)	Viessmann
④	Air intake component	Field
⑤	Air intake increaser (if required) (3 in. to 4 in.)	Field
⑥	Boiler coaxial adaptor (80 mm / 125 mm)	C/W Boiler
⑦	Air intake connection	

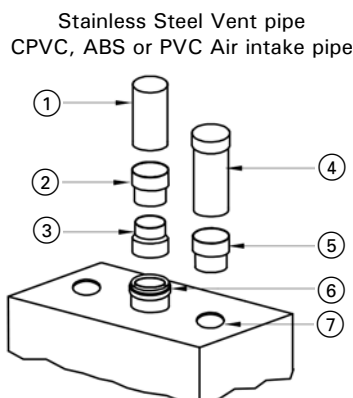

#	Component	Supplied
①	Vent Component	Field
②	Vent increaser (if required) (3 in. to 4 in.)	Field
③	Vent starter adaptor (SS), (80 mm to 3 in.)	Field
④	Air intake component	Field
⑤	Air intake increaser (if required) (3 in. to 4 in.)	Field
⑥	Boiler coaxial adaptor (80 mm / 125 mm)	C/W Boiler
⑦	Air intake connection	

IMPORTANT

For PP(s) systems, all exhaust vent and air intake piping and elbows exposed outside, must be UV resistant polypropylene (supplied by the vent manufacturer).

C/W Boiler indicates "Complete with Boiler".

Single Pipe Options (Room Air Dependent) (with boiler coaxial adaptor 80/125)

IMPORTANT

For PP(s) systems, all exhaust vent and air intake piping and elbows exposed outside, must be UV resistant polypropylene (supplied by the vent manufacturer).

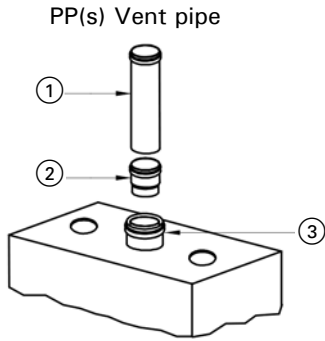

PP(s) Vent pipe		
#	Component	Supplied
①	Vent Component	Field
②	Vent increaser (if required) (80 mm to 100 or 110 mm)	Field
③	Boiler coaxial adaptor (80 mm / 125 mm)	C/W Boiler

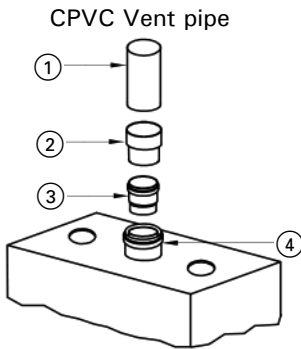

CPVC Vent pipe		
#	Component	Supplied
①	Vent Component	Field
②	Vent increaser (if required) (3 in. to 4 in.)	Field
③	Vent starter adaptor (CPVC), (80 mm to 3 in.)	Viessmann
④	Boiler coaxial adaptor (80 mm / 125 mm)	C/W Boiler

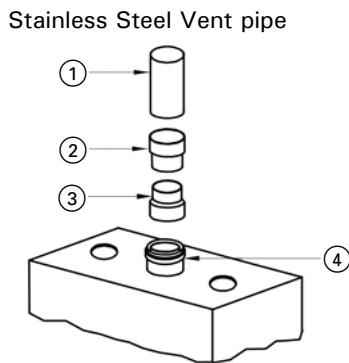

Stainless Steel Vent pipe		
#	Component	Supplied
①	Vent Component	Field
②	Vent increaser (if required) (3 in. to 4 in.)	Field
③	Vent starter adaptor (SS), (80 mm to 3 in.)	Field
④	Boiler coaxial adaptor (80 mm / 125 mm)	C/W Boiler

Two Pipe Options (Direct Vent) (with boiler coaxial adaptor 60/100 with air intake connection)

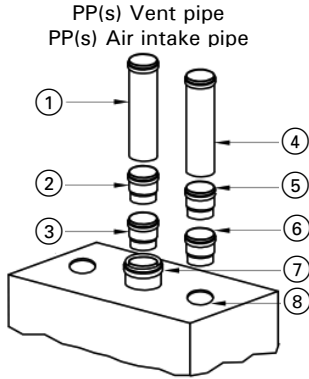

#	Component	Supplied
①	Vent Component	Field
②	Vent increaser (if required) (80 mm to 100 or 110 mm)	Field
③	Vent increaser (if required) (60 mm to 80 mm)	Field
④	Air intake component	Field
⑤	Air intake increaser (if required) (80 mm to 100 or 110 mm)	Field
⑥	Air intake increaser (if required) (60 mm to 80 mm)	Field
⑦	Boiler coaxial adaptor (60 mm / 100 mm)	C/W Boiler
⑧	Air intake connection	

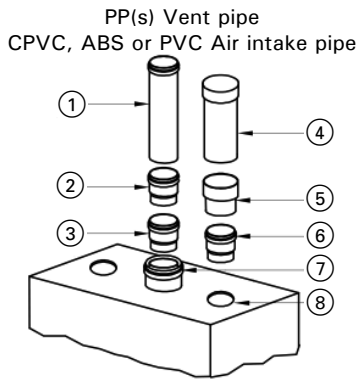

#	Component	Supplied
①	Vent Component	Field
②	Vent increaser (if required) (80 mm to 100 or 110 mm)	Field
③	Vent increaser (if required) (60 mm to 80 mm)	Field
④	Air intake component	Field
⑤	Air intake increaser (if required) (2 in. to 3 in. or 4 in.)	Field
⑥	Air intake adaptor (if required) (60 mm to 2 in.)	Viessmann
⑦	Boiler coaxial adaptor (60 mm / 100 mm)	C/W Boiler
⑧	Air intake connection	

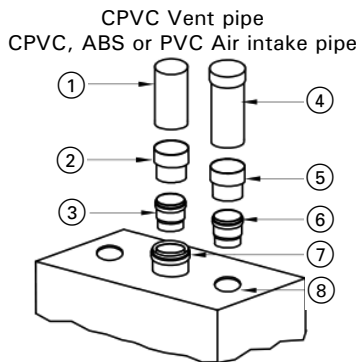

#	Component	Supplied
①	Vent Component	Field
②	Vent increaser (if required) (2 in. to 3 in. or 4 in.)	Field
③	Vent starter adaptor (CPVC), (60 mm to 2 in.)	Viessmann
④	Air intake component	Field
⑤	Air intake increaser (if required) (2 in. to 3 in. or 4 in.)	Field
⑥	Air intake adaptor (60 mm to 2 in.)	Viessmann
⑦	Boiler coaxial adaptor (60 mm / 100 mm)	C/W Boiler
⑧	Air intake connection	

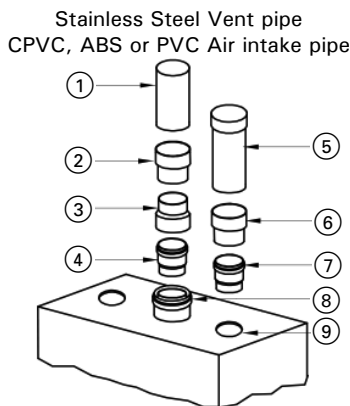

#	Component	Supplied
①	Vent Component	Field
②	Vent increaser (if required) (3 in. to 4 in.)	Field
③	Vent starter adaptor (SS), (80 mm to 3 in.)	Field
④	Vent starter adaptor (PPs), (60 mm to 80 mm)	Viessmann
⑤	Air intake component	Field
⑥	Air intake increaser (if required) (2 in. to 3 in. or 4 in.)	Field
⑦	Air intake adaptor (60 mm to 2 in.)	Viessmann
⑧	Boiler coaxial adaptor (60 mm / 100 mm)	C/W Boiler
⑨	Air intake connection	

IMPORTANT

For PP(s) systems, all exhaust vent and air intake piping and elbows exposed outside, must be UV resistant polypropylene (supplied by the vent manufacturer).

C/W Boiler indicates "Complete with Boiler".

Single Pipe Options (Room Air Dependent) (with boiler coaxial adaptor 60/100)

IMPORTANT

For PP(s) systems, all exhaust vent and air intake piping and elbows exposed outside, must be UV resistant polypropylene (supplied by the vent manufacturer).

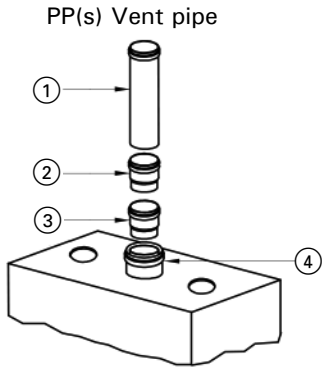

PP(s) Vent pipe		
#	Component	Supplied
①	Vent Component	Field
②	Vent increaser (if required) (80 mm to 100 or 110 mm)	Field
③	Vent increaser (if required), (60 mm to 80 mm)	Field
④	Boiler coaxial adaptor (60 mm / 100 mm)	C/W Boiler

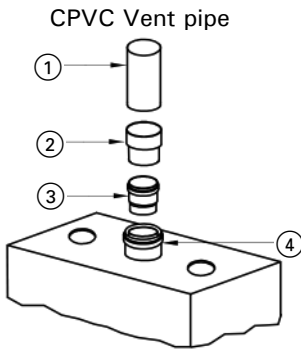

CPVC Vent pipe		
#	Component	Supplied
①	Vent Component	Field
②	Vent increaser (if required) (2 in. to 3 in. or 4 in.)	Field
③	Vent starter adaptor (CPVC), (60 mm to 2 in.)	Viessmann
④	Boiler coaxial adaptor (60 mm / 100 mm)	C/W Boiler

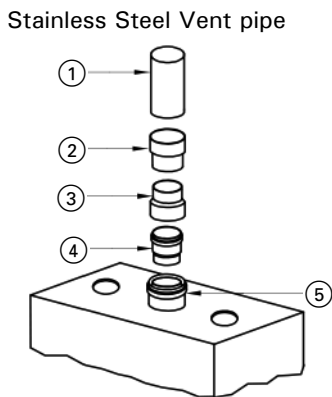

Stainless Steel Vent pipe		
#	Component	Supplied
①	Vent Component	Field
②	Vent increaser (if required) (3 in. to 4 in.)	Field
③	Vent starter adaptor (SS), (80 mm to 3 in.)	Field
④	Vent starter adaptor (PPs), (60 mm to 80 mm)	Field
⑤	Boiler coaxial adaptor (60 mm / 100 mm)	C/W Boiler

Two Pipe Options (Direct Vent) (with boiler coaxial adaptor 80/125 and two pipe adaptor)

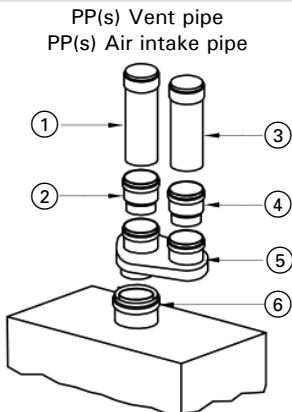

#	Component	Supplied
①	Vent Component	Field
②	Vent increaser (if required) (80 mm to 100 or 110 mm)	Field
③	Air intake component	Field
④	Air intake increaser (if required) (80 mm to 100 or 110 mm)	Field
⑤	Double pipe adaptor (80 mm/125 mm to 80 mm and 80 mm)	Viessmann
⑥	Boiler coaxial adaptor (80 mm / 125 mm)	C/W Boiler

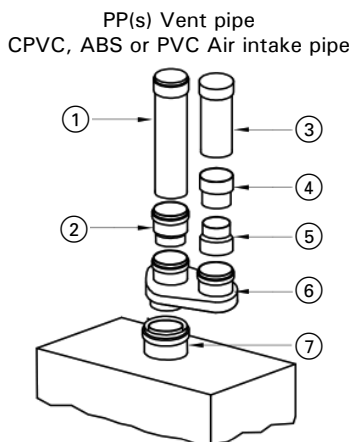

#	Component	Supplied
①	Vent Component	Field
②	Vent increaser (if required) (80 mm to 100 or 110 mm)	Field
③	Air intake component	Field
④	Air intake increaser (if required) (3 in. to 4 in.)	Field
⑤	Air intake adaptor (80 mm to 3 in.)	Viessmann
⑥	Double pipe adaptor, (80 mm/125 mm to 80 mm and 80 mm)	Viessmann
⑦	Boiler coaxial adaptor (80 mm / 125 mm)	C/W Boiler

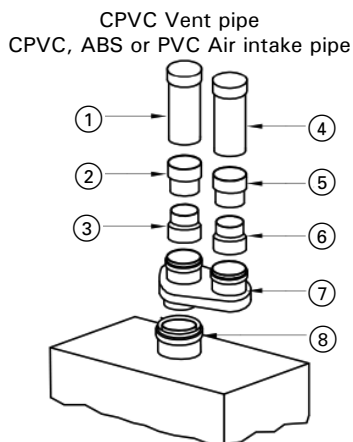

#	Component	Supplied
①	Vent Component	Field
②	Vent increaser (if required) (3 in. to 4 in.)	Field
③	Vent adaptor, (80 mm to 3 in.)	Viessmann
④	Air intake component	Field
⑤	Air intake increaser (if required) (3 in. to 4 in.)	Field
⑥	Air intake adaptor (80 mm to 3 in.)	Viessmann
⑦	Double pipe adaptor (80 mm/125 mm to 80 mm and 80 mm)	Viessmann
⑧	Boiler coaxial adaptor (80 mm / 125 mm)	C/W Boiler

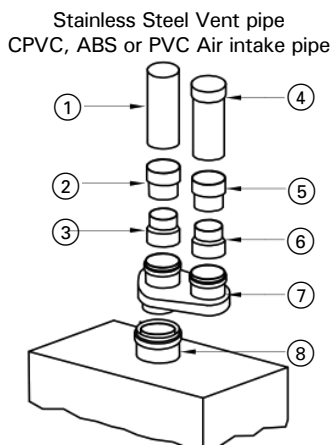

#	Component	Supplied
①	Vent Component	Field
②	Vent increaser (if required) (3 in. to 4 in.)	Field
③	Vent starter adaptor (SS), (80 mm to 3 in.)	Field
④	Air intake component	Field
⑤	Air intake increaser (if required) (3 in. to 4 in.)	Field
⑥	Air intake adaptor (80 mm to 3 in.)	Viessmann
⑦	Double pipe adaptor (80 mm/125 mm to 80 mm and 80 mm)	Viessmann
⑧	Boiler coaxial adaptor (80 mm / 125 mm)	C/W Boiler

IMPORTANT

For PP(s) systems, all exhaust vent and air intake piping and elbows exposed outside, must be UV resistant polypropylene (supplied by the vent manufacturer).

Single Pipe Options (Room Air Dependent) (with boiler coaxial adaptor 80/125)

IMPORTANT

For PP(s) systems, all exhaust vent and air intake piping and elbows exposed outside, must be UV resistant polypropylene (supplied by the vent manufacturer).

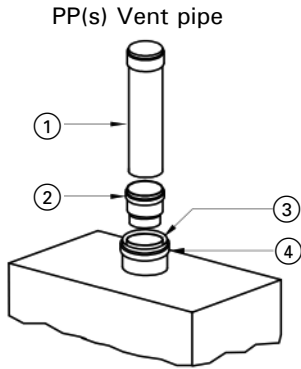

PP(s) Vent pipe		
#	Component	Supplied
①	Vent Component	Field
②	Vent increaser (if required) (80 mm to 100 or 110 mm)	Field
③	Combustion air inlet (location)	
④	Boiler coaxial adaptor (80 mm / 125 mm)	C/W Boiler

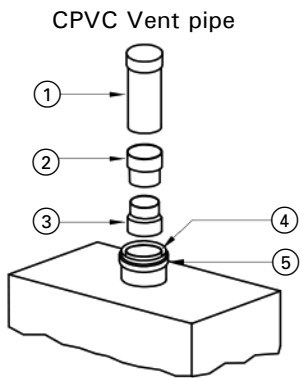

CPVC Vent pipe		
#	Component	Supplied
①	Vent Component	Field
②	Vent increaser (if required) (3 in. to 4 in.)	Field
③	Vent adaptor, (80 mm to 3 in.)	Viessmann
④	Combustion air inlet (location)	
⑤	Boiler coaxial adaptor (80 mm / 125 mm)	C/W Boiler

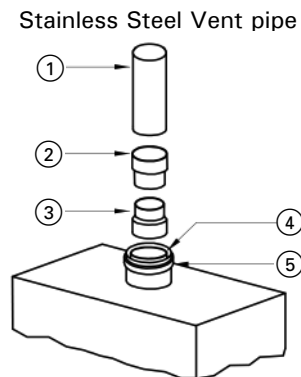

Stainless Steel Vent pipe		
#	Component	Supplied
①	Vent Component	Field
②	Vent increaser (if required) (3 in. to 4 in.)	Field
③	Vent starter adaptor (SS), (80 mm to 3 in.)	Field
④	Combustion air inlet (location)	
⑤	Boiler coaxial adaptor (80 mm / 125 mm)	C/W Boiler

Two Pipe Options (Direct Vent) (with boiler coaxial adaptor 110/150)

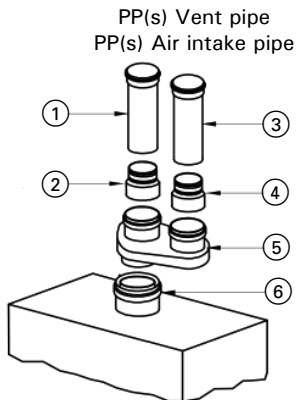

#	Component	Supplied
①	Vent Component (100 mm or 110 mm)	Field
②	Vent starter adaptor, (110 mm to 100*)	Field
③	Air intake component	Field
④	Air intake starter adaptor, (110 mm to 100*)	Field
⑤	Double pipe adaptor (110 mm/150 mm to 110 mm and 110 mm)	Viessmann
⑥	Boiler coaxial adaptor (110 mm / 150 mm)	C/W Boiler

* with M&G / Duravent system only.

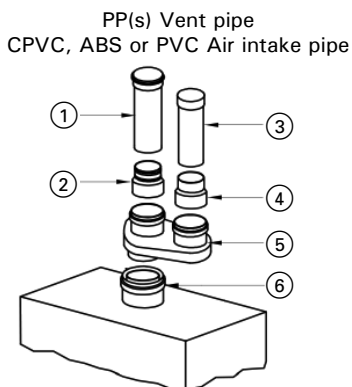

#	Component	Supplied
①	Vent Component (100 mm or 110 mm)	Field
②	Vent starter adaptor, (110 mm to 100*)	Field
③	Air intake component	Field
④	Air intake starter adaptor, (110 mm to 4 in.)	Viessmann
⑤	Double pipe adaptor (110 mm/150 mm to 110 mm and 110 mm)	Viessmann
⑥	Boiler coaxial adaptor (110 mm / 150 mm)	C/W Boiler

* with M&G / Duravent system only.

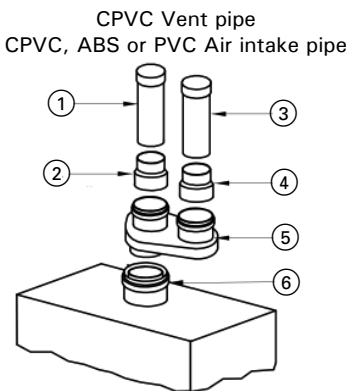

#	Component	Supplied
①	Vent Component	Field
②	Vent starter adaptor, (110 mm to 4 in.)	Viessmann
③	Air intake component	Field
④	Air intake starter adaptor, (110 mm to 4 in.)	Viessmann
⑤	Double pipe adaptor (110 mm/150 mm to 110 mm and 110 mm)	Viessmann
⑥	Boiler coaxial adaptor (110 mm / 150 mm)	C/W Boiler

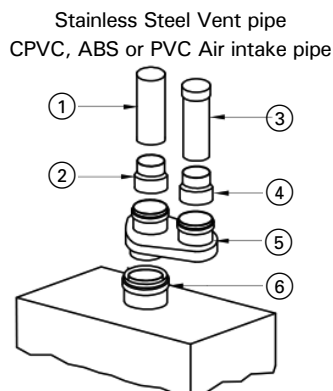

#	Component	Supplied
①	Vent Component	Field
②	Vent starter adaptor (SS), (110 mm to 4 in.)	Field
③	Air intake component	Field
④	Air intake starter adaptor, (110 mm to 4 in.)	Viessmann
⑤	Double pipe adaptor (110 mm/150 mm to 110 mm and 110 mm)	Viessmann
⑥	Boiler coaxial adaptor (110 mm / 150 mm)	C/W Boiler

IMPORTANT

For PP(s) systems, all exhaust vent and air intake piping and elbows exposed outside, must be UV resistant polypropylene (supplied by the vent manufacturer).

Single Pipe Options (Room Air Dependent) (with boiler coaxial adaptor 110/150)

IMPORTANT

For PP(s) systems, all exhaust vent and air intake piping and elbows exposed outside, must be UV resistant polypropylene (supplied by the vent manufacturer).

PP(s) Vent pipe

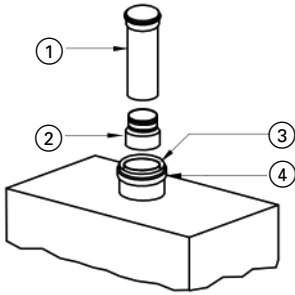

PP(s) Vent pipe		
#	Component	Supplied
①	Vent Component (100 mm or 110 mm)	Field
②	Vent starter adaptor (110 mm to 100*)	Field
③	Combustion air inlet (location)	
④	Boiler coaxial adaptor (110 mm / 150 mm)	C/W Boiler

* with M&G / Duravent system only.

CPVC Vent pipe

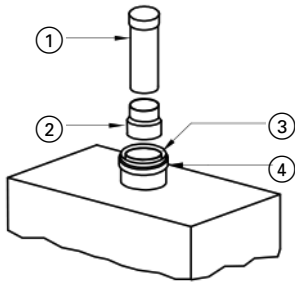

CPVC Vent pipe		
#	Component	Supplied
①	Vent Component	Field
②	Vent starter adaptor (110 mm to 4 in.)	Viessmann
③	Combustion air inlet (location)	
④	Boiler coaxial adaptor (110 mm / 150 mm)	C/W Boiler

Stainless Steel Vent pipe

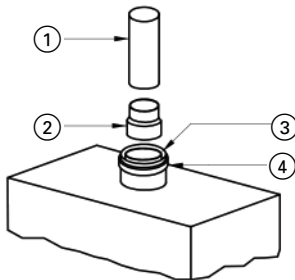

Stainless Steel Vent pipe		
#	Component	Supplied
①	Vent Component	Field
②	Vent starter adaptor (SS), (110 mm to 4 in.)	Field
③	Combustion air inlet (location)	
④	Boiler coaxial adaptor (110 mm / 150 mm)	C/W Boiler

Coaxial Vent System Options (Direct Vent)

IMPORTANT

For PP(s) systems, all exhaust vent and air intake piping and elbows exposed outside, must be UV resistant polypropylene (supplied by the vent manufacturer).

B1HA 26, 35, 94, 125, B1KA 35, 125
 B2TB 19, 35, 68, 125, B2HA 19, 28, 35,
 B2HB 19, 26, 35, 68, 94, 125

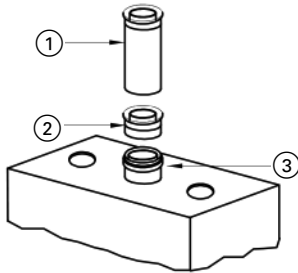

**B1HA 26, 35, 94, 125, B1KA 35, 125
 B2HA 19, 28, 35 B2TB 19, 35,
 B2HB 19, 26, 35, 68, 94, 125**

#	Component	Supplied
①	Vent Component	Field
②	Vent increaser (if required), (60 mm/100 mm to 80 mm/125 mm) (60 mm/100 mm to 100 mm/150 mm) (60 mm/100 mm to 110 mm/160 mm)	Field M&G/Duravent Centrotherm
③	Boiler coaxial adaptor (60 mm / 100 mm)	C/W Boiler

B2HA 45, 60, B2HB 45, 57, 160, 199,
 B2HA 19, 28, 35, B2HB 19, 26, 35, 68, 94, 125)
 B1HE 85, 120, 150, 199, B1KE 120, 199,
 B2HE 85, 120, 150, 199

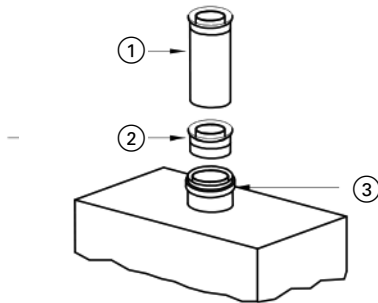

**B2HA 45, 60
 B2HB 45, 57, 160, 199
 B1HE 85, 120, 150, 199
 B1KE 120, 199
 B2HE 85, 120, 150, 199**

#	Component	Supplied
①	Vent Component	Field
②	Vent increaser (if required), (80 mm/125 mm to 100 mm/150 mm) (80 mm/125 mm to 110 mm/160 mm)	Field M&G/Duravent Centrotherm
③	Boiler coaxial adaptor (80 mm / 125 mm)	C/W Boiler

B2HA 80,100,112,150, 285, 352, 399, 530

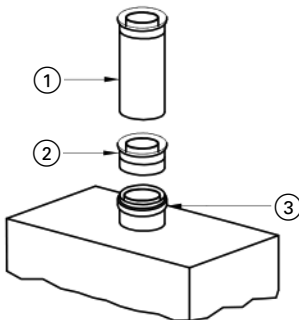

B2HA 80, 100, 112, 150, 285, 352, 399, 530

#	Component	Supplied
①	Vent Component	Field
②	Vent starter adaptor, (required), (150 mm/110 mm to 150 mm/100 mm) (150 mm/110 mm to 160 mm/110 mm)	M&G / Duravent Centrotherm
③	Boiler coaxial adaptor (110 mm / 150 mm)	C/W Boiler



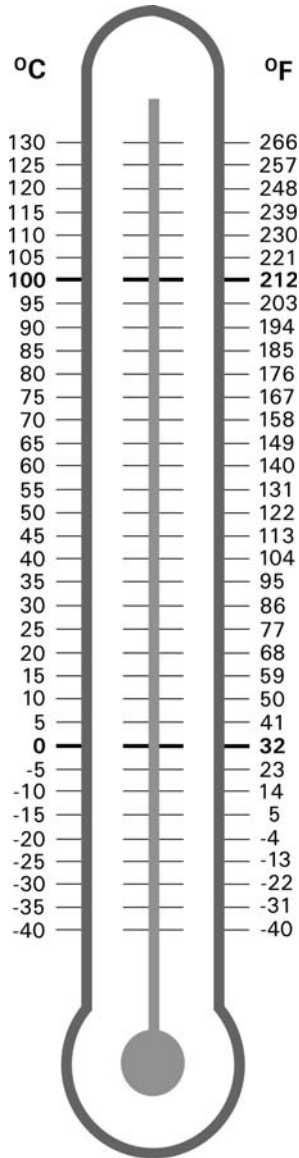

Printed on environmentally friendly
(recycled and recyclable) paper.

Technical information subject to change without notice.

Scan for
digital copy
of this
document



Viessmann Manufacturing Company Inc.
750 McMurray Road
Waterloo, Ontario • N2V 2G5 • Canada
TechInfo Line 1-888-484-8643
1-800-387-7373 • Fax (519) 885-0887
www.viessmann.ca • info@viessmann.ca

Viessmann Manufacturing Company (U.S.) Inc.
45 Access Road
Warwick, Rhode Island • 02886 • USA
TechInfo Line 1-844-649-5886
1-800-288-0667 • Fax (401) 732-0590
www.viessmann-us.com • info@viessmann-us.com