

PERFORMANCE PLATINUM™



The new degree of comfort®

PERFORMANCE PLATINUM™ Super High Efficiency Condensing Tankless Gas Water Heaters

Easy Installation

- PVC Vent runs up to 60' (2"), 150' (3")
- Enhanced design is up to 20% smaller and lighter making one-person installs even easier

Ready for Retrofits

- **Industry Best!** 1/2" side to side clearance allows you to safely work in spaces the competition can't
- 1/2" Gas line compatibility (subject to local code)

Key Features

- **Rheem® Exclusive!** Hot-start Programming™ ensures the unit is in a ready state between back-to-back usage, minimizing any cold water bursts
- Built-in EcoNet® Wi-Fi technology for direct control from your device (on select models)
- LeakGuard® – All-inclusive leak detection and prevention system that detects any leak that comes from the unit (on indoor Wi-Fi models)



Vent termination included.

Specifications

| Rheem Model Number | ECOH160DVLN-3 | | |
|--------------------------------------|---------------|---|------------------------------|
| Built-in LeakGuard™ Model Number | | ECOH180DVELN-3 (Wi-Fi Model) | ECOH200DVELN-3 (Wi-Fi Model) |
| Gas Input Rate | MAX | 157,000 BTU/h | 180,000 BTU/h |
| | MIN | 11,000 BTU/h | 11,000 BTU/h |
| Uniform Energy Factor (UEF) | | 0.93 | |
| Gallons Per Minute (GPM) | MAX (35°F) | 8.4 | 9.0 |
| | 45°F Rise | 6.7 | 7.7 |
| | 67°F Rise | 4.6 | 5.2 |
| Number of Bathrooms ¹ | | 3 | 3 - 4 |
| Temp. Range | | 100°F - 140°F | |
| Temp. Setting from Factory | | 120°F | |
| High Temp. Upgrade Available | | No | |
| Freeze Protection | | -30°F Air Intake ² , -4°F Ambient | |
| Installation Type | | Indoor (Outdoor Conversion Kit sold separately: RTGH-X) | |
| Heat Exchanger Material | | Primary: Copper – Secondary: Stainless Steel | |
| Minimum Activation Flow | | 0.4 GPM | |
| Minimum Continuous Flow | | 0.26 GPM | |
| Maximum Altitude | | 7,800 ft. | |
| Ultra Low NOx | | Meets 14 ng/J NOx requirements - SCAQMD Rule 1146.2 compliant | |
| Warranty | | 15 year Heat Exchanger 5-Year Parts 1-Year Labor | |
| Height | | 23.7" | |
| Width | | 17.7" | |
| Depth | | 9.8" | |
| Weight (Lbs.) | | 52.9 | |
| Venting Diam. Allowed | | 2" / 3" | |
| Max. Single Vent Run (straight pipe) | | 60 ft (2") / 150 ft (3") | |
| Venting Materials | | Sched. 40 PVC, CPVC, Polypropylene | |
| Manifold Controls (max. units) | | 6 Units ³ | |
| Controls | | Built-in digital display | |
| Power Supply | | 120V 60Hz | |
| Max. Power Consumption | | 85W (Normal use), 0.7 Amps 132W (Antifreeze), 1.1 Amps 3.5W (Standby), 0.03 Amps ⁴ | |
| Gas Connection | | 3/4" NPT | |
| Hot Water Connection | | 3/4" NPT | |
| Cold Water Connection | | 3/4" NPT | |
| Condensate Connection | | 1/2" NPT | |
| Vent Connections Diameter | | 2" Band Connections (Adapter required to vent with 3" PVC from unit) | |

*Swap P for N in model number for Liquid Propane model

PERFORMANCE PLATINUM Super High Efficiency Condensing Tankless

Indoor Models
(Outdoor Conversion Kit Available:
RTGH-X)
11,000-199,900 BTU/h
Natural Gas and
Liquid Propane Models*



| Clearances | |
|-----------------------|-------------------|
| Top / Bottom | 12" |
| Front | 1/2" ⁵ |
| Sides | 1/2" |
| Back / From Vent Pipe | 0" |

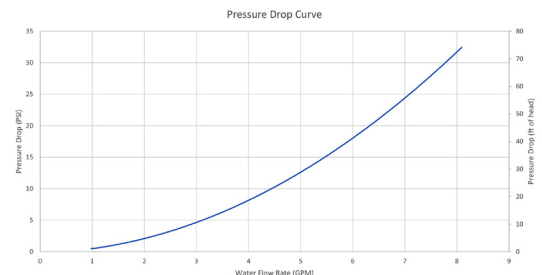

¹ Based on simultaneous showers using 2.5 GPM flow rate pre-mixed with cold water line. Flow rates vary depending on temperature of incoming cold water and water heater set temperature. Refer to flow rate curves for accurate sizing. ² For indoor application, this is the temperature of outdoor intake air. ³ Manifolds with standard RJ11 communication cables. ⁴ If anti freeze is on and combustion is on, total W will be 217W (85+132). ⁵ Recommended 24" clearance for service.

PERFORMANCE PLATINUM™ Super High Efficiency Condensing Tankless Gas Water Heaters



The new degree of comfort.™

Water Heater Flow Rate Curves

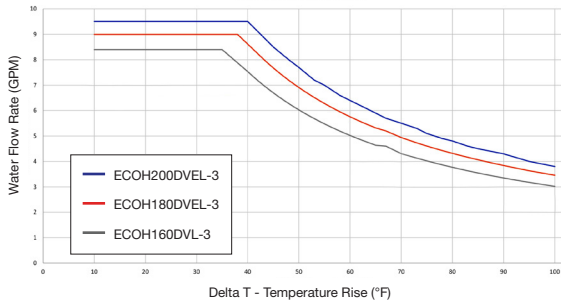

Water Flow (GPM)

| Model Number | Temperature Rise (°F) | | | | | | | | | |
|---------------|-----------------------|-----|-----|-----|-----|-----|-----|-----|------|--|
| | 35° | 45° | 50° | 60° | 67° | 70° | 80° | 90° | 100° | |
| ECOH200DVEL-3 | 9.5 | 8.5 | 7.7 | 6.4 | 5.7 | 5.5 | 4.8 | 4.3 | 3.8 | |
| ECOH180DVEL-3 | 9.0 | 7.7 | 6.9 | 5.8 | 5.2 | 4.9 | 4.3 | 3.8 | 3.5 | |
| ECOH160DVL-3 | 8.4 | 6.7 | 6.0 | 5.0 | 4.6 | 4.3 | 3.8 | 3.3 | 3.0 | |

Above estimates are for sizing purposes only.

Dimensions

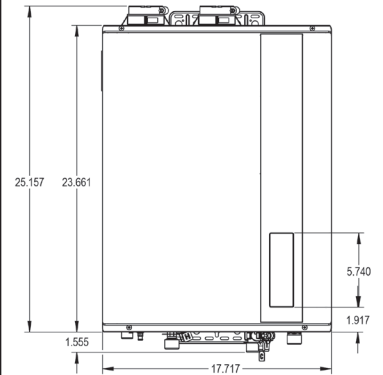

TOP VIEW

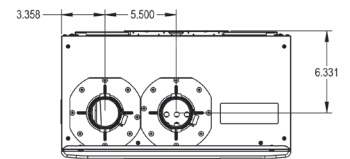

BOTTOM VIEW

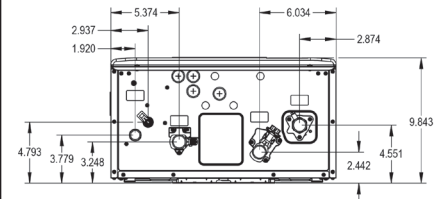

Venting

SINGLE UNIT: MAX. EQUIVALENT VENT LENGTHS - STRAIGHT PIPE

| Number of 90° Elbows | Max Length 2" straight pipe | Max. length 3" straight pipe |
|----------------------|-----------------------------|------------------------------|
| 0 | 60 ft. (18.3 m) | 150 ft. (45.7 m) |
| 1 | 54 ft. (16.5 m) | 144 ft. (43.9 m) |
| 2 | 48 ft. (14.6 m) | 138 ft. (42.7 m) |
| 3 | 42 ft. (12.8 m) | 132 ft. (40.2 m) |
| 4 | 36 ft. (11.0 m) | 126 ft. (38.4 m) |
| 5 | 30 ft. (9.1 m) | 120 ft. (36.6 m) |
| 6 | 24 ft. (7.3 m) | 114 ft. (34.7 m) |

Equivalent Ft. of Elbows

| | 2" Pipe | 3" Pipe |
|-----------|----------------|----------------|
| 90° Elbow | 6 ft. (1.83 m) | 6 ft. (1.83 m) |
| 45° Elbow | 3 ft. (0.9 m) | 3 ft. (0.9 m) |

Venting Materials Allowed: Schedule 40 PVC, CPVC, Polypropylene

Min. Vent Length Straight Pipe

| Number of 90° Elbows | Min. Length 2" 3" pipe |
|----------------------|------------------------|
| 1 | 1.0 ft (0.3 m) |

Hanging bracket, pressure relief valves, and bird screens are included with water heater.

Parts & Accessories

| Condensate Neutralizer | Recirculation Pump | Pipe Cover | Horizontal Vent Termination | Concentric Vent Termination | AllClear® Water Treatment System | Manifold Cables | Outdoor Conversion Kit | Isolation Valve Kit |
|------------------------|--------------------|------------|------------------------------------|------------------------------|----------------------------------|----------------------------------|------------------------|---------------------|
| RTG20329AR (optional) | AP17920 | AP22097 | 2" US: SP21069G 3" US: SP21069E | 2" - SP20897 3" - SP20245 | RTG20251 | RCPN-AMP03-0013111101-0003 (48") | RTGH-X | RTG20326 |
| | | | | | | | | |

In keeping with its policy of continuous progress and product improvement, Rheem reserves the right to make changes without notice.